



ADVANCED WORKHOLDING PUMPS, 1-HP

VEKTEK LLC
1334 EAST 6th AVE
EMPORIA, KS 66801
1-800-992-0236
www.vektek.com



PL-5595, REV. V, I.A.W. ECN 5642
PAGE 1 of 214

VektorFlo® is a registered trademark of Vektek LLC

Vektek LLC reserves the right to change specifications without notice in an ongoing product improvement process.

Vektek LLC
1334 East 6th Ave
Emporia, KS 66801
1-800-992-0236
sales@vektek.com
www.vektek.com

PUMP MODEL No. _____

PUMP SERIAL NO. _____

IN SERVICE DATE _____

TABLE OF CONTENTS

	<u>Page</u>
Preliminary and Safety Information (Section I).....	4
Hydraulic Fluid (Section II).....	7
Pump Installation (Section III).....	8
A. Specifications	
B. Set-up	
C. Pressure Switch Adjustment	
D. VFD rPi Adjustments	
E. Air Bleeding	
F. Pump Fault	
Control Valves (Section IV).....	14
Pump Operations (Section V).....	15
Maintenance (Section VI).....	34
A. Intervals	
B. Parts Lists	
C. Wiring Diagrams	
D. Basic Pump Schematic	
Trouble Shooting (Section VII).....	151
Warranty and Return Information (Section VIII).....	153
Hydraulic Fluid SDS (Section IX).....	155
ATV12 Variable Frequency Drive Diagnostics and Troubleshooting.....	Appendix A
ATV320 Variable Frequency Drive Diagnostics and Troubleshooting.....	Appendix B
Vektek Electronic Pressure Switch Specifications and Programming.....	Appendix C

SECTION I

PRELIMINARY AND SAFETY INFORMATION

FAILURE TO HEED THE FOLLOWING INFORMATION WILL VOID WARRANTY

Preliminary Information

Most malfunctions in new equipment are the result of improper set-up and operation. Please read and fully understand the entire enclosed information.

Remove the pump from the shipping container. **DO NOT** remove plugs or valves until unit is ready to be installed to prevent any foreign matter from contaminating the system.

Visually inspect all components for shipping damage and correct configuration. Report any damage found to the carrier or factory immediately.

Connect the pump to the power source per wiring diagram in section V.
Power supply must be of the same rating or equipment damage may occur.

This pump is equipped with SAE o-ring type ports for all external hydraulic connections. SAE o-ring fittings seal by compressing a resilient o-ring in a specially designed chamfer in the port. With this type of connection, **DO NOT** use pipe dope, thread sealing tape, or other materials. Such materials may contaminate the hydraulic system and damage the sealing surfaces of the valves. Detection of such materials will void the pump warranty.

This pump is equipped with an electric switch that shuts the pump motor off when it reaches a preset pressure. The motor will automatically restart if the system pressure falls to the reset point of the pressure switch. The pump also includes an electric fluid level switch that will shut the pump motor off if the fluid level is too low.

When connected to a properly functioning clamping system, the hydraulic pressure may bleed down very slowly after the pump motor stops. Depending upon the size and complexity of the system, the motor should restart only once every five to ten minutes, after the system is fully pressurized.

SECTION I

PRELIMINARY AND SAFETY INFORMATION (continued)

Safety

1.0 Working Pressure

The maximum pump working pressure is 5,000 psig. Make sure that all hydraulic equipment used with this pump is rated at 5,000 psig working pressure.

WARNING

Failure to use such rated equipment may result in system failure, property damage, or bodily injury.

2.0 Hydraulic Connections

Threaded connections such as fittings must be securely tightened. Quick disconnect couplings must be securely engaged and undamaged. **NEVER** disconnect or connect any hydraulic fittings under pressure.

WARNING

Loose or improperly threaded fittings can pose a potential safety hazard. **NEVER** touch or contact a hydraulic leak in any way. Failure to follow this warning may result in escaping high pressure fluid penetrating the skin and causing serious bodily injury.

3.0 Electrical Power

- A. Check for proper electrical supply before connecting power.
- B. If using an extension cord, be certain that it is properly sized for the current load, see section III.
- C. **DO NOT** use a power cord that is damaged.
- D. **DO NOT** use an ungrounded extension cord or power outlet, as the motor must be grounded.
- E. Pump is equipped with a Totally Enclosed Fan Cooled (TEFC) motor. It is not explosion proof and may spark.
- F. **DO NOT** operate in an explosive atmosphere or in the presence of combustible or conductive liquids.

WARNING

Failure to follow this information may cause an explosion resulting in property damage or bodily injury.

SECTION I

PRELIMINARY AND SAFETY INFORMATION (continued)

4.0 Operating Safely

WARNING

DO NOT connect or disconnect from the pump while under pressure. First turn the pump motor off. Then slowly shift the valve through all positions to completely depressurize the system. Check gage(s) to verify that all system pressure has been relieved.

Keep the operator thinking. Set and enforce work rules that help avoid property or bodily injury. Make certain all operators are properly trained.

SECTION II

HYDRAULIC FLUID

VektorFlo® hydraulic oil, p/n 65-0010-01 (one gallon), is recommended for all Vektek pumps operating in ambient temperatures above 5°F (-15°C).

VektorFlo® hydraulic oil is a premium grade petroleum based fluid with detergent and anti-wear additives. VektorFlo® hydraulic oil also includes additives to inhibit corrosion, rust, oxidation, and foaming.

VektorFlo® Hydraulic Oil Characteristics:

Pour Point.....	-35°F (-37°C)
Flash Point.....	421°F (216°C) (COC)
Viscosity	31 cSt @ 104°F (40°C)
.....	5.4 cSt @ 212°F (100°C)
ISO Viscosity Grade.....	32

You may also substitute other brands of oil rated at ISO grade 32. Vektek recommends completely draining existing oil before any substitution is made.

Use of hydraulic oil with a viscosity grade higher than ISO 32 may cause sluggish return action of single acting devices and should therefore, only be used on double acting systems. ISO grade 46 is compatible with Vektek pumps and may be used if deemed necessary.

Use of hydraulic oil with a viscosity grade lower than ISO 32 may cause an increase in oil flow to all devices connected to the pump. This should be addressed with flow control devices if necessary.

ISO grade 22 is compatible with Vektek pumps and may be used if deemed necessary.

MSDS sheet, see section IX.

SECTION III

PUMP INSTALLATION

A. Specifications

Voltage (VAC)	Phase (PH)	Current (A)	Cycles (Hz)	RPM	Rotation*
100-120	1	18.9-15.7	50/60	1750	Clockwise
200-240	1	10.2-8.5	50/60	1750	Clockwise
200-240	3	6.3-5.3	50/60	1750	Clockwise
380-500	3	3.6-2.7	50/60	1750	Clockwise
525-600	3	1.5-1.4	50/60	1750	Clockwise

* Looking at fan side of motor.

Valves	71-1122-54 71-1150-03	71-1122-13 71-1150-05	71-1235-21	71-1235-22	71-1235-40	71-1235-41
Current	1.2A	0.3A	1.2A	0.2A	1.2A	0.3A
Approx. Inrush	1.3A	0.4A	1.3A	0.3A	1.3A	0.4A

1. Flow Rate
 - a. Low Pressure.....350in³/min @ 700 psig
 - b. High Pressure.....50 in³/min @ 5,000 psig
2. Maximum Operating Pressure.....5,000 psig
3. Fluid Capacity
 - a. Nominal.....1155 in³ (5 gal)
 - b. Useable.....808 in³ (3.5 gal)
4. Safety Overpressure Relief.....Integral to Manifold
5. Filtration
 - a. Integral Pump Suction Screen.....100 micron
 - b. Integral Manifold Sintered Bronze.....25 micron
 - c. Return Line Filter cartridge10 micron
6. Pressure Switch
 - a. Contacts.....Normally Closed (PNP)
 - b. Rating.....500 mA @ 24VDC
7. Fluid Level Sensor
 - a. Contacts.....Normally Closed
 - b. Rating.....1 A @ 24VAC
8. Motor Input from Variable Frequency Drive3.2 A, 230 VAC, 3-PH
9. Duty Cycle.....100%
10. Hydraulic Connections.....SAE o-ring

SECTION III

PUMP INSTALLATION (continued)

B. Set-up

BEFORE turning pump on, check the hydraulic oil level on the external sight glass. With all cylinders retracted and the pump motor off, the oil level should be approximately ½ inch below the reservoir top plate. If unsure of the oil level, verify the oil level by opening the reservoir fill cap located on the reservoir top plate. Add oil, Vektek p/n 65-0010-01 (one gallon), as necessary.

Verify that all desired gage, valve, hose, and quick coupler connections are tightened properly before operating, see below for pump connection ports. The pump is equipped with SAE #6 o-ring connections located on the front surface of the manifold block or on the ends of the valve blocks, depending on the model number. Use **ONLY** SAE #6 o-ring style fittings to connect to these ports.

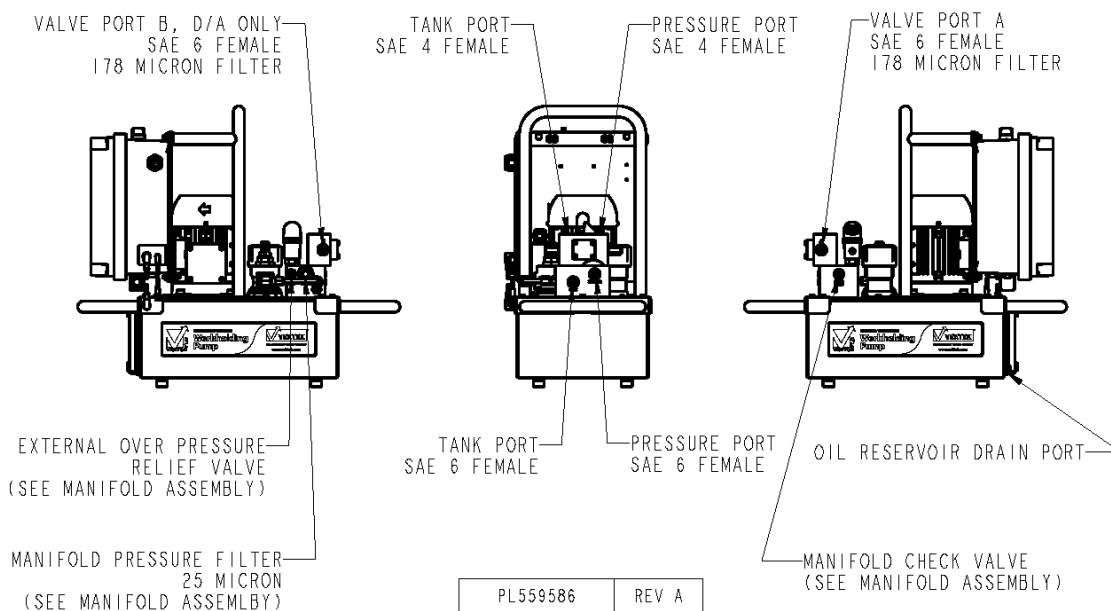

Momentarily bump the power switch to “JOG” to check for the proper rotation of the electric motor. The motor should rotate in the direction of the arrow on the motor. If rotation is incorrect, turn off all electrical power service to pump enclosure. Remove enclosure lid and switch L2 and L3 wires on incoming power service to breaker inside pump enclosure. Replace enclosure lid and turn on electrical power service to pump enclosure. Turn selector switch to "JOG" and confirm the correct motor rotation. When the electric system is on, and the system is pressurized, the motor will shut-off at the pressure set by the factory, approximately 5,000 psig. The pressure is controlled by the adjustable system pressure switch.

During the initial set-up of any new system, it is recommended that the pressure switch be set to the minimum pressure required to operate the system components. Cycling the system at low pressure should reveal most oversights in the installation such as stroke, interference, loose fitting connections, and clamp positioning. After checking the system at low pressure, re-set the pressure switch as described in the Pressure Switch Adjustment section to operate the system at the desired pressure.

SECTION III

PUMP INSTALLATION (continued)

C. Pressure Switch Adjustment

1. Pump must be connected to a fixture or other device, rated at 5,000 psig that requires fluid volume to set the pressure switch.
2. Turn the pump on, position the control valve to the clamp position, and note the pressure switch reading at which the pump shuts off.
3. To change the pressure switch set point, select, and hold the “Down” arrow so “SP1” is displayed and select the center “Programming Mode” button to modify the value. Then select the “Up” or “Down” arrow and hold to adjust the Set Point 1 pressure up or down as required. The rate of change on the display will increase the longer the arrow buttons are held down. When the desired pressure is reached on the display, select the center “Programming Mode” button to save this value to “SP1”. Next, select the “Down” arrow again so “RP1” is displayed and select the “Programming Mode” button to modify the value. Then select the “Up” or “Down” arrow and hold to adjust the Reset Point 1 pressure up or down as required. This value should be approximately 10% below the “SP1” value for proper hysteresis of the pressure switch. If the spread in the “SP1” and “RP1” values are too low, this will cause the pump to “cycle” repeatedly as pressure is slowly lost in the system due to temperature change and would be undesirable. If the spread is too high, the system pressure could drop to a level that is below an acceptable operation level for sufficient clamping force.

IMPORTANT: The “RP1” value must be set below that of the “SP1” value and may need to be adjusted down first to achieve the desired pressure switch settings. **NEVER** attempt to adjust the pressure switch setting to more than 5,000 psig. (range = 1000-5000 psig).



NOTICE The pressure switch supplied with the pump is for the control of motor function only. It is not intended to interface with machine controllers or to be used for process control. If a pressure switch is required for process control, it is recommended that a separate switch be installed downstream from the control valves or that a Vekttek Pallet Pressure Monitor system be used.

NOTICE See Appendix for pressure switch programming menu.

SECTION III

PUMP INSTALLATION (continued)

D. VFD rPi Adjustment

For optimal operation of the pump, the PID reference value “rPi” in the VFD should be adjusted to match the desired operating pressure. This value is automatically adjusted in Machine Control Ethernet Systems.

IMPORTANT: Removal of electrical Enclosure lid to be done by qualified personnel only.

1. Turn off all electrical service to the pump
2. Remove the enclosure lid.
3. Turn on electrical service to the pump.
4. The VFD display will show “nST” or “fST”. Click the rotary dial once.
5. “rEF” will display. Click dial again.
6. A value will appear on the display.
 - a. ATV12 models will display a percentage.
 - b. ATV320 models display a PSI number.
7. Use the rotary dial to set the value (based on SP1). Click dial to confirm.
 - a. ATV12: to determine the needed percentage, divide SP1 by 6000.
 - b. ATV320: input value equal to SP1.
8. Press the “ESC” button. “rPi” will display.
 - a. ATV320: will automatically back out to “rPi” after 2 seconds.
9. Press “ESC” to return to “rEF”.
10. Press “ESC” to return to “nST” or “fST”.



SECTION III

PUMP INSTALLATION (continued)

E. Bleeding Air From The System

Sluggish or jerky device action is usually an indication of air in the system. Accordingly, remove as much air from the system as possible using the following procedures.

Bleeding air from the hydraulic system can be a tedious task. The following suggestions should help.

Air naturally moves toward the highest point in the circuit or device. Elevating the pump to a height greater than the fixture and cycling the control valves several times will usually evacuate most of the air.

If the system proves to be particularly difficult to bleed, install a bleeder in the system or perform the following procedure. Starting at a connection that is either farthest from the pump, or highest in the system, carefully loosen (crack) a fitting enough to allow a small stream of oil to escape. **DO NOT** fully remove the fitting under hydraulic pressure as bodily injury may occur. The appearance of “milky” oil indicates that air is being evacuated from the system. When the oil is clear, retighten the fitting and check for normal system operation. Repeat this procedure with subsequent fittings closer to the pump, or lower in the system.

WARNING

NEVER touch or contact a hydraulic leak in any way. Failure to follow this warning may result in escaping high pressure fluid penetrating the skin and causing serious bodily injury.

E. Pump Fault

In the case of a pump fault, the fault pushbutton on the top of the control enclosure will illuminate. Please see the troubleshooting section for causes of the fault and additional information to troubleshoot the pump.

To reset a fault (fault condition corrected):

1. Turn ON/OFF/JOG selector to “OFF” Position.
2. Press FAULT pushbutton.
 - a. Fault Light Should no longer be illuminated. If the fault light is still illuminated after pressing the FAULT pushbutton, the fault is still present. See the Section VI Troubleshooting for further diagnosis.
3. Return the ON/OFF/JOG selector to the “ON” position to return normal operation.

F. Machine Control E-Stop Relay Circuit Configuration

Pumps are shipped with the E-Stop Relay #2 circuit configured to Normally Closed PIN 12 when the relay is in the de-energized state. In this way, the pump will run and +24VDC is fed to the VFD Input 4 if the E-Stop relay PIN A5 is NOT connected to the CNC Machine E-Stop relay circuit.

If the E-Stop Relay PIN A5 is connected to the CNC Machine E-Stop relay circuit, the E-Stop Relay #2 circuit can be configured to the Normally Closed PIN 12 position or the Normally Open PIN 14 position when the relay is in the de-energized state. Final configuration is to be done by the customer or integrator at their own discretion depending on the intended function for Machine E-Stop

1. Normally Closed Circuit for feeding +24VDC to VFD Input 4 if E-Stop Relay #2 is in de-energized state.

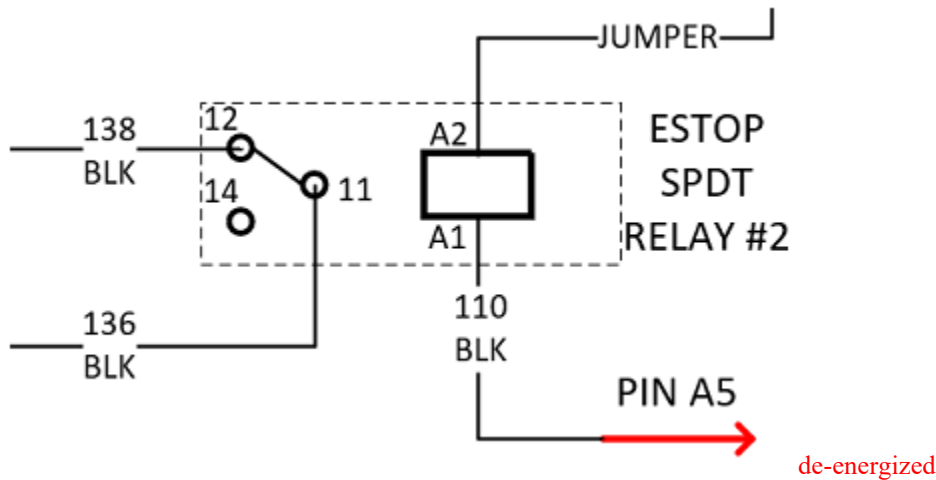

2. Normally Open Circuit for NOT feeding +24VDC to VFD Input 4 if E-Stop Relay #2 is in de-energized state. PIN A5 must be energized to switch E-Stop #2 relay and feed +24VDC to VFD Input 4 to allow pump to run.

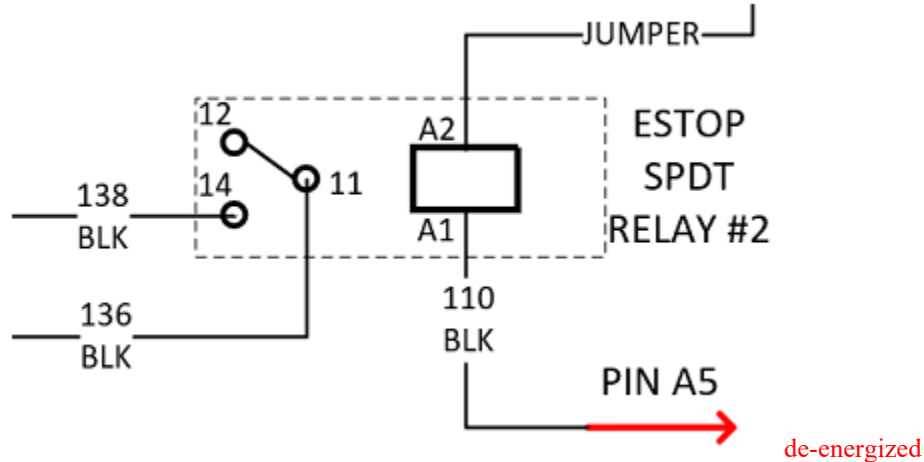

SECTION IV

CONTROL VALVES

When starting any pump, caution should be taken to avoid sudden or undesired system movement. Move handles on manual valves and pendant switches to the appropriate position.

CAUTION

On manual valves, if the handle is not fully engaged in a detent position, the clamps may move but full clamping force may not be achieved. Always make sure that the handles are completely adjusted to the desired position.

SECTION V

PUMP OPERATION

A. General Operation of All Advanced Workholding Pumps

1. The Advanced Workholding Pump is very energy efficient due to the on-demand operation of the pressure switch control system. When the pump manifold pressure drops below the pressure switch reset point, the motor turns on until the pressure switch set point is reached, and then turns off. Shifting of directional control valves connected to the pump manifold will cause loss of hydraulic pressure in the manifold system below the pressure switch reset point and activate the pumping system until manifold pressure is restored to the pressure switch set point value. The pump motor is active only on-demand to provide hydraulic pressure to the manifold system.

B. Safe Operation Instructions, All Pumps (67040067)

1. Before Operating Pump

- a. Turn pump motor switch to OFF position.
- b. Check reservoir oil level and fill to the top of the oil level sight glass if required. Fill with clean VectorFlo ISO grade 32 hydraulic oil P/N 65-0010-01. Do not over-fill reservoir to allow room for oil from return line.
- c. Connect pump electrical box to the proper electrical service with ground according to the pump specifications for voltage, phase, and current requirements. If an extension cord is required, see Pump Installation Section for proper wire gauge and maximum wire run length.
- d. Connect pump hydraulics to workholding system using industry accepted plumbing methods and components rated for at least 5000 PSI (350 bar) operating pressure. Insure that all plumbing connections are tight with no leaks.

2. To Operate Pump

- a. Set all manual or electric valves to the OFF or Center position to insure hydraulic pressure is contained within the pump manifold system.
- b. Turn electrical service to pump ON. Digital pressure switch will illuminate indicating power to pump is ON.
- c. Push fault reset button if it is illuminated. If the red FAULT light is still illuminated, disconnect the pump from electrical service. See the Pump Trouble Shooting Section for proper diagnosis and service by a qualified service technician.

SECTION V

PUMP OPERATION (continued)

- d. Set digital pressure switch set point SP1 value to the maximum desired hydraulic pressure. (See the Pump Operations Manual for a complete guide to pressure switch function and setting.)
- e. Set digital pressure switch reset point RP1 value to the minimum desired hydraulic pressure. RP1 value is typically 300-500 PSI (20-35 Bar) less than SP1 value.
- f. Turn pump/motor selector switch to JOG position and hold. Pump/motor will run until SP1 maximum hydraulic pressure is reached within the pump manifold and then will stop. Pump/motor may cycle on and off several times until hydraulic accumulator on pump manifold is fully charged and system pressure is stabilized at SP1 setting. If there are any leaks in the hydraulic system, immediately release the pump/motor selector switch from the JOG position to the OFF position. Correct any leaks in hydraulic system before proceeding to the next step.
- g. Turn pump/motor selector switch to ON position for normal operation.

3. To Operate Hydraulic Valves if so Equipped

- a. Manual valves operate by moving valve handle to the desired position to allow hydraulic oil flow and pressurization of the connected system. When the digital pressure switch SP1 value is reached and stabilized, the pump/motor will stop.
- b. Electric hydraulic valves operate by moving the valve pendant switch to the desired position to allow hydraulic oil flow and pressurization of the connected system. When the digital pressure switch SP1 value is reached and stabilized, the pump/motor will stop.
- c. Do not disconnect a pressurized hydraulic system with the valve or valves in the ON position. First, remove system pressure by switching the valves to the OFF or Center position, releasing all hydraulic pressure to tank. The hydraulic system can then be disconnected from the pump safely.

4. To Maintain Operation of Pump

- a. Air in the hydraulic system can cause erratic behavior of the pump. See the Pump Installation Section for detailed instructions on bleeding air from the hydraulic system.

SECTION V

PUMP OPERATION (continued)

- b. If the red FAULT light on top of the electrical enclosure is illuminated, check the oil level in the sight glass to insure that it is adequate to allow operation of the pump. If the oil level is in the lower half of the sight glass, fill with clean VectorFlo ISO grade 32 hydraulic oil P/N 65-0010-01 until oil reaches the top of the oil level sight glass. Press the red Fault Light pushbutton to reset the Fault condition.
- c. If the red FAULT light is still illuminated, turn the pump/motor selector switch to the OFF position and disconnect the pump from electrical service. See the Pump Trouble Shooting Section for proper diagnosis and service by a qualified service technician.
- d. Oil temperature should not exceed 150° F (65° C). Excessive oil temperature is a symptom of device, pump, or valve failure. See the Pump Trouble Shooting Section for proper diagnosis and service by a qualified service technician.
- e. This hydraulic pump requires periodic maintenance to insure proper function and reliability. Clean hydraulic oil will significantly extend the life of the pump. See the Pump Maintenance Section for a detailed pump maintenance description and schedule.

C. Specific Pump Configuration Operating Instructions

1. Manifold Only Pump

- a. This pump configuration is intended to be used as a central or remote power supply for a hydraulic fixture system. It is configured with a Pressure Port and Tank Port in the front of the manifold for easy connection.
- b. Valves for this pump are not supplied but can be purchased separately from Vektek to be remote mounted closer to the fixture.
- c. Valve connection and control is the responsibility of the customer as no M12 I/O block is supplied with this configuration of pump.

2. D03 Stack Block or Manual Valve Pump

- a. This pump configuration is intended to be used with customer supplied DO3 directional control valves. Only zero-leak poppet style valves should be used as the pump functions as an on-demand hydraulic power supply. **Warning:** The use of spool valves invalidates the warranty on VektorFlo® pumps.
- b. Valve connection and control is the responsibility of the customer as no M12 I/O block is supplied with this configuration of pump.

SECTION V

PUMP OPERATION (continued)

3. Pendant 24VDC Operated Pump

- a. 1-4 Valve control by pendant allows the operator to individually control 1, 2, 3, or 4 valves with the appropriate pendants configured for each valve type. Each pendant is connected to the right hand M12 I/O block on the back of the electrical enclosure mounting panel using the M12 port adjacent to the port the valve cable is connected to as shown below. One pendant is supplied with each pump so if there are multiple valves, additional pendants for each valve will need to be added to the order. All pendants are 24VDC low voltage control for safe operation. The M12 I/O block is supplied with 120 watts of 24VDC power from the electrical enclosure for up to 4 valves.

1-4 Valve Pendant I/O Block Function

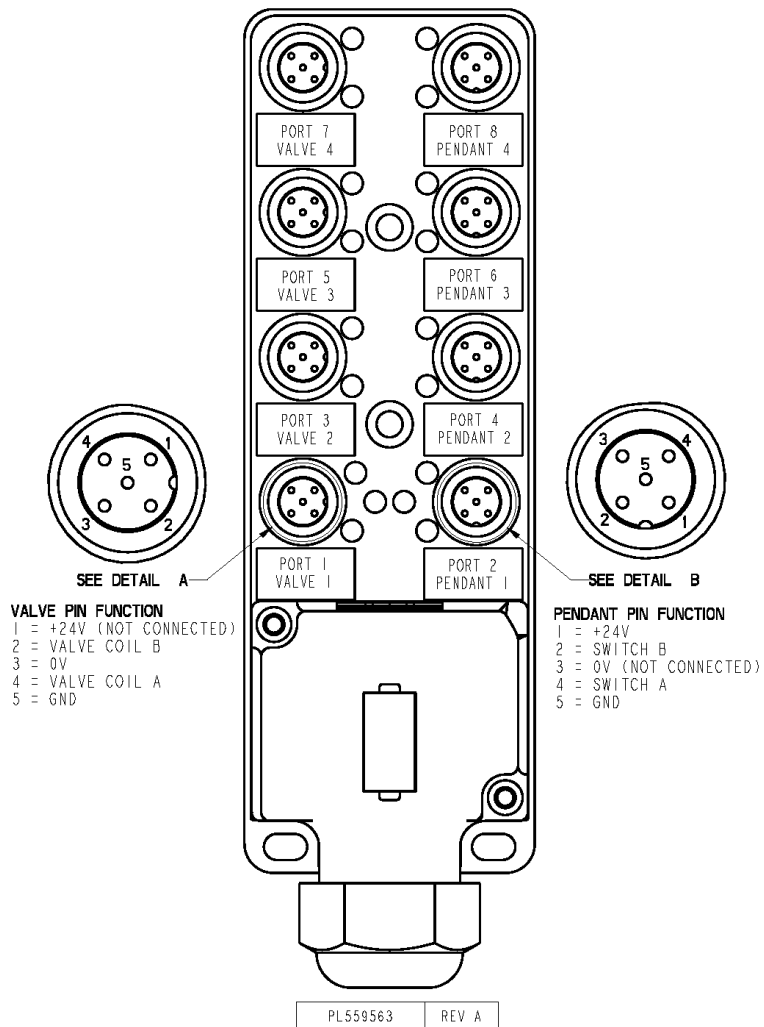

SECTION V

PUMP OPERATION (continued)

- b. 5-6 Valve control by pendant allows the operator to individually control 1, 2, 3, 4, 5, or 6 valves with the appropriate pendants configured for each valve type. The first 4 pendants are connected to the right hand I/O block on the back of the electrical enclosure mounting panel using the M12 port adjacent to the port the valve cable is connected to as shown above. The 5th or 6th pendants are connected to the left hand I/O block as shown below. One pendant is supplied with each pump so if there are multiple valves, additional pendants for each valve will need to be added to the order. All pendants are 24VDC low voltage control for safe operation. The M12 I/O block is supplied with 240 watts of 24VDC power from the electrical enclosure for up to 6 valves.

5-6 Valve Pendant I/O Block Function

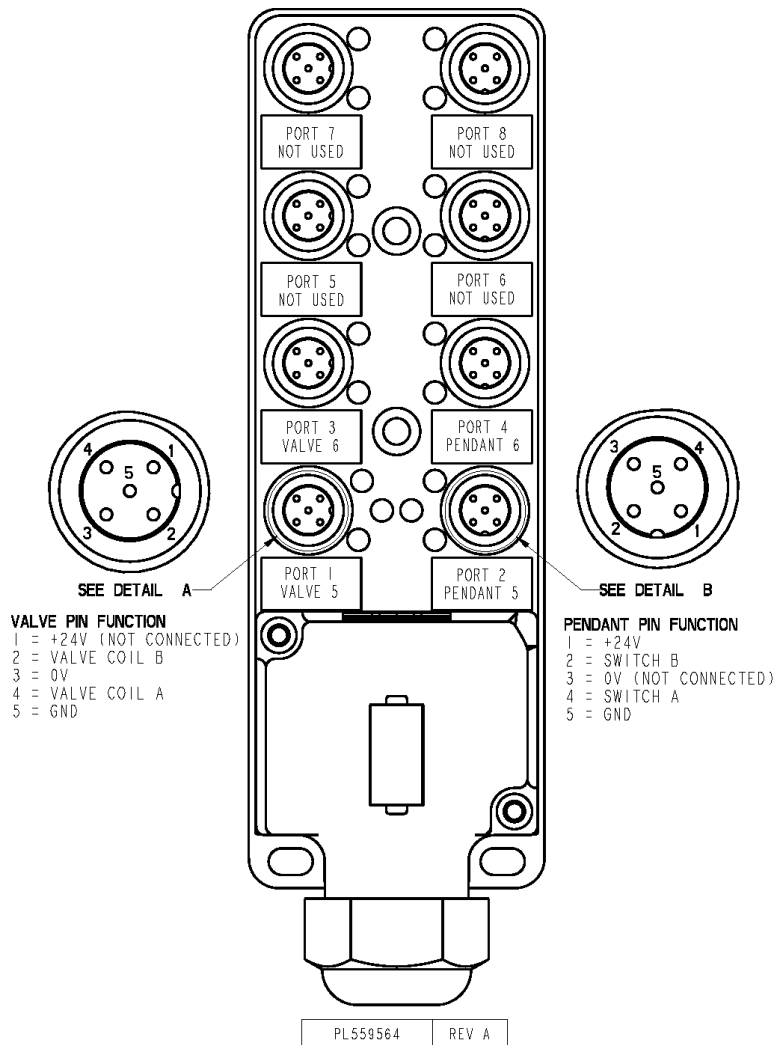

SECTION V

PUMP OPERATION (continued)

4. Valve Control Cable Operated Pump

a. This pump configuration is intended to allow simple valve control from the CNC Machine Tool PLC controller. Each valve has an individual M12 cable kit added to connect the M12 I/O port adjacent to the port the valve cable is connected to in place of the operator pendant control. Connection of the M12 cable to the CNC Machine Tool PLC controller is the responsibility of the customer. Standard cable length is 16.4 ft (5M). The wire colors that correspond to the pin numbers on the cable are as shown below with their function. **IMPORTANT** When connecting the male end to the I/O Block, 24VDC power is supplied by the pump power supply, NOT the CNC Machine Tool PLC controller. Connection to the PLC is for dry contact switching purposes only.

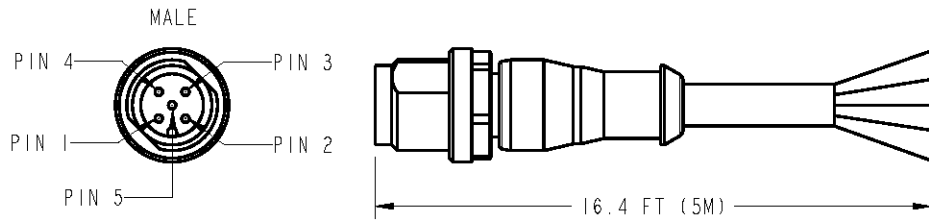

PIN NO.	WIRE COLOR	FUNCTION	3/2 VALVE	4/3 VALVE
1	BROWN	+24V	CONNECT	CONNECT
2	WHITE	VALVE COIL B	DO NOT CONNECT	CONNECT
3	BLUE	0V	DO NOT CONNECT	DO NOT CONNECT
4	BLACK	VALVE COIL A	CONNECT	CONNECT
5	GREEN/YELLOW	GROUND	CONNECT	CONNECT

PL559565	REV A
----------	-------

SECTION V

PUMP OPERATION (continued)

5. Mechanical Pressure Switch with Cable Option (under valve stack)

- a. Mechanical pressure switches can be added under each valve via A-B tapping plate to monitor pressure of either the A port, B port, or both. Adjustment of this switch is done by rotating the knurled knob clockwise to increase the pressure switch set point and counter-clockwise to decrease it. Switch the pump on and monitor the pressure gauge next to the pressure switch to determine the setting. Continue to adjust as needed until the desired pressure switch set point is reached. Connection of this mechanical pressure switch to the machine tool controller requires only 2 of the 3 available wires for the desired operation, either a normally open or normally closed switch. See table below for proper connection of male M8 pressure switch connector.

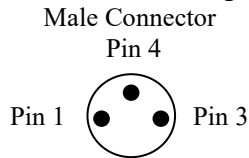

Pin No.	Wire Color	Function
1	Brown	Normally Open
2	N/A	N/A
3	Blue	Voltage Input
4	Black	Normally Closed

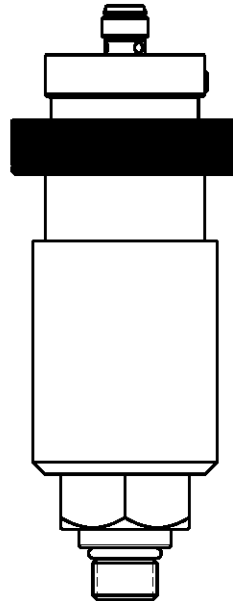

SECTION V

PUMP OPERATION (continued)

6. Electronic pressure switches can be added under each valve via A-B tapping plate to monitor pressure of either the A port, B port, or both. Adjustment of this switch is done by selecting the “Programming Mode” button and then the up or down arrow buttons as needed. (See Installation and Pressure Switch Adjustment section of this manual.) Switch the pump on and monitor the LED display of the pressure switch to verify the setting. Connection of this electronic pressure switch to the machine tool controller is accomplished by the 16.4 ft (5M) M12 cable that is supplied with the switch. It has a Male end connector for the machine tool controller and a Female end connector for the pressure switch. The Male end connector can be cut and wires stripped for bare wire connection if required.

IMPORTANT 24VDC power must be supplied by the CNC Machine Tool PLC. See table below for proper connection for the desired function.

(See Appendix C for complete Operating Instructions and setup)

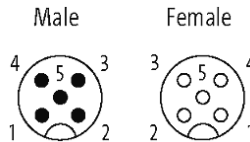

Pin No.	Wire Color	Function
1	Brown	+24V
2	White	Analog Signal
3	Blue	- 0V
4	Black	Set Point 1
5	Green/Yellow	Set Point 2



SECTION V

PUMP OPERATION (continued)

7. Machine Tool Interface Control Operated Pump

a. Complete integration of the pump, valves, and pressure switches to the CNC machine can be accomplished with 1 of 3 options, all using the Harting Series Han 10B connector system in a single 16 ft (5M) cable. The Harting Series Han 10B connector utilizes A, B, or C modules with 12 pins each to connect valve control, pressure switch monitoring, and pump status monitoring. In the standard 1-4 valve or 5-6 valve system, power for the pump motor is supplied in a separate service cable. In the optimized 1-4 valve system, power for the pump motor is included in the C module of the single machine tool interface cable (5-6 valve not possible). Each system is supplied with a mating female cable receptacle with a 16 ft (5M) pig tail to be mounted and connected to the machine tool PLC. (See illustrations for each type.) The pump is supplied with a mating male cable receptacle that is already prewired to the pump enclosure for complete control. Input pump status monitoring for each configuration includes oil level, oil temperature, oil filter clog indicator, and VFD fault status. Output from PLC to pump include emergency stop and fault rest. This allows for complete control and monitoring of the pump system in all configurations. All Machine Tool Interface Control options must be configured at the time order and built at the factory. These options cannot be added or upgraded in the field.

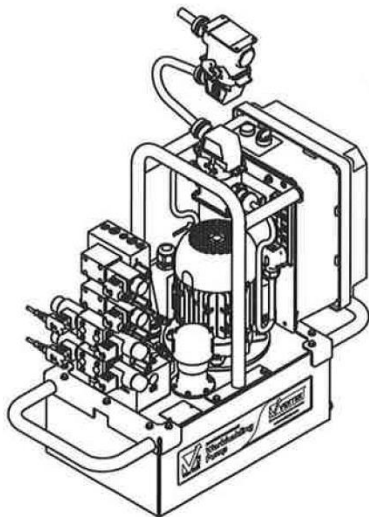

1-4 Valve Machine Tool Interface
without Power

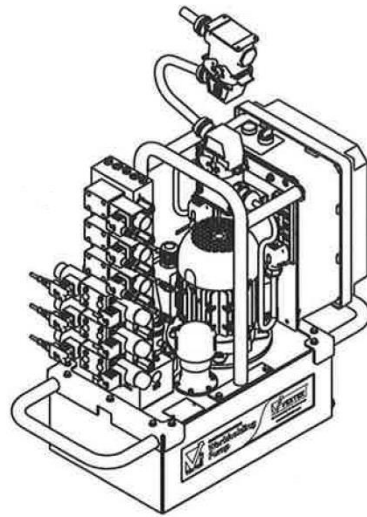

5-6 Valve Machine Tool Interface
without Power

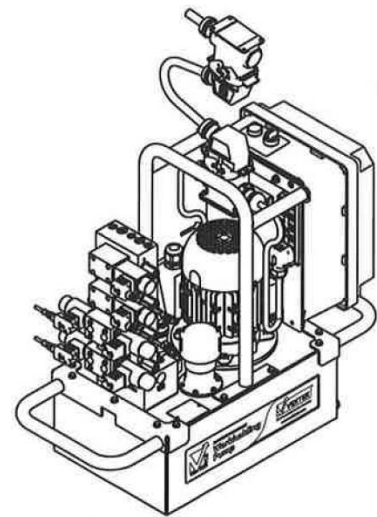

1-4 Valve Machine Tool Interface
with Power

SECTION V

PUMP OPERATION (continued)

b. Standard 1-4 Valve Machine Tool Interface Control (without power)
See table below for pin out and description of function.

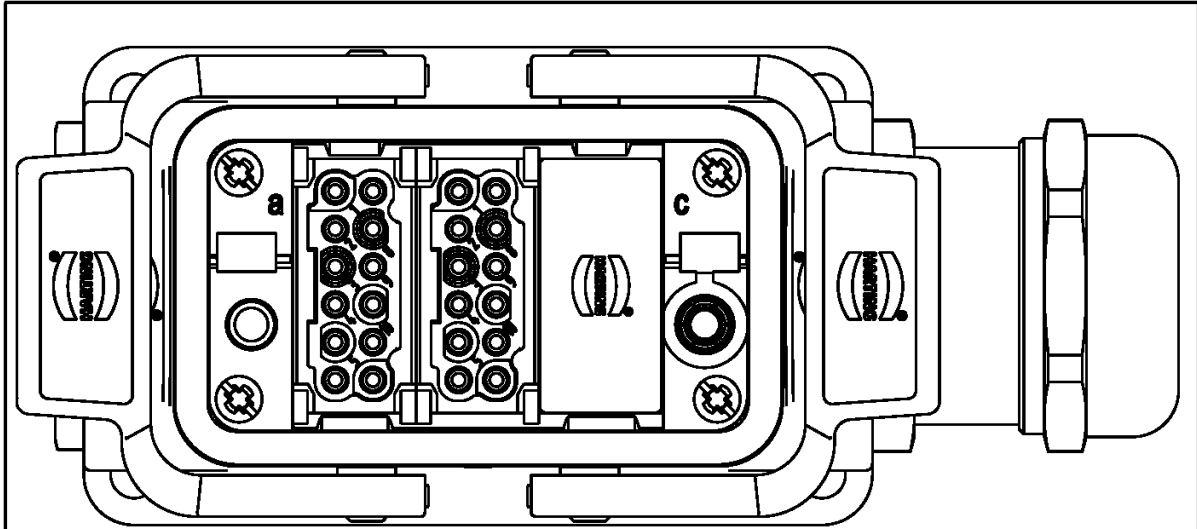

MODULE /PIN NO.	MACHINE WIRE NO.	I/O BLOCK/ PORT/PIN NO.	WIRE COLOR/ WIRE NO.	PUMP WIRE NO.	INPUT/OUTPUT FUNCTION	SIGNAL DESCRIPTION
A1	1	1/1/4	WHITE	162	OUTPUT TO VALVE 1, A PORT	24 VDC, 26 W, SOURCE TO SOLENOID
A2	2	1/1/2	GRY-PNK	164	OUTPUT TO VALVE 1, B PORT	24 VDC, 26 W, SOURCE TO SOLENOID
A3	3	1/3/4	YELLOW	170	OUTPUT TO VALVE 2, A PORT	24 VDC, 26 W, SOURCE TO SOLENOID
A4	4	1/3/2	WHT-GRN	172	OUTPUT TO VALVE 2, B PORT	24 VDC, 26 W, SOURCE TO SOLENOID
A5	5	-	BLACK / 2	110	OUTPUT TO E-STOP RELAY AI	24 VDC, SOURCE TO RELAY COIL
A6	6	1/ALL/1	BRN & BLK / 1	114	OUTPUT TO ALL VLVS & P.S. 24 VDC POWER	24 VDC, 120 WATTS MINIMUM
A7	7	1/2/4	GREEN	166	INPUT FROM PRESSURE SWITCH 1, A PORT	24 VDC, SOURCE TO PLC
A8	8	1/2/2	RED-BLU	168	INPUT FROM PRESSURE SWITCH 1, B PORT	24 VDC, SOURCE TO PLC
A9	9	1/4/4	GRAY	174	INPUT FROM PRESSURE SWITCH 2, A PORT	24 VDC, SOURCE TO PLC
A10	10	1/4/2	BRN-GRN	176	INPUT FROM PRESSURE SWITCH 2, B PORT	24 VDC, SOURCE TO PLC
A11	11	-	BLACK / 3	112	OUTPUT TO FAULT RESET RELAY AI	24 VDC, SOURCE TO RELAY COIL
A12	12	1/ALL/3	BLU & BLK / 8	116	OUTPUT TO ALL VLVS & P.S. COMMON	0 VDC
B1	13	1/5/4	PINK	178	OUTPUT TO VALVE 3, A PORT	24 VDC, 26 W, SOURCE TO SOLENOID
B2	14	1/5/2	WHT-YLW	180	OUTPUT TO VALVE 3, B PORT	24 VDC, 26 W, SOURCE TO SOLENOID
B3	15	1/7/4	BLACK	186	OUTPUT TO VALVE 4, A PORT	24 VDC, 26 W, SOURCE TO SOLENOID
B4	16	1/7/2	WHT-GRY	188	OUTPUT TO VALVE 4, B PORT	24 VDC, 26 W, SOURCE TO SOLENOID
B5	17	-	BLACK / 4	102	INPUT FROM LEVEL SWITCH RELAY AI	N/C RELAY CONTACT
B6	18	-	BLACK / 6	108	INPUT FROM FILTER CLOG SWITCH RELAY AI	N/C RELAY CONTACT
B7	19	1/6/4	RED	182	INPUT FROM PRESSURE SWITCH 3, A PORT	24 VDC, SOURCE TO PLC
B8	20	1/6/2	YLW-BRN	184	INPUT FROM PRESSURE SWITCH 3, B PORT	24 VDC, SOURCE TO PLC
B9	21	1/8/4	VIOLET	190	INPUT FROM PRESSURE SWITCH 4, A PORT	24 VDC, SOURCE TO PLC
B10	22	1/8/2	GRY-BRN	192	INPUT FROM PRESSURE SWITCH 4, B PORT	24 VDC, SOURCE TO PLC
B11	23	-	BLACK / 5	104	INPUT FROM TEMPERATURE SWITCH RELAY AI	N/C RELAY CONTACT
B12	24	-	BLACK / 7	106	INPUT FROM VFD FAULT SWITCH RELAY AI	N/C RELAY CONTACT FOR NO DRIVE FAULT
GND	GRN-YLW	1/ALL/5	GRN-YLW	118	GROUND FOR ALL VALVE OUTPUTS	N/A

PL559566 REV B

SECTION V

PUMP OPERATION (continued)

c. Standard 5-6 Valve Machine Tool Interface Control (without power)
See table below for pin out and description of function.

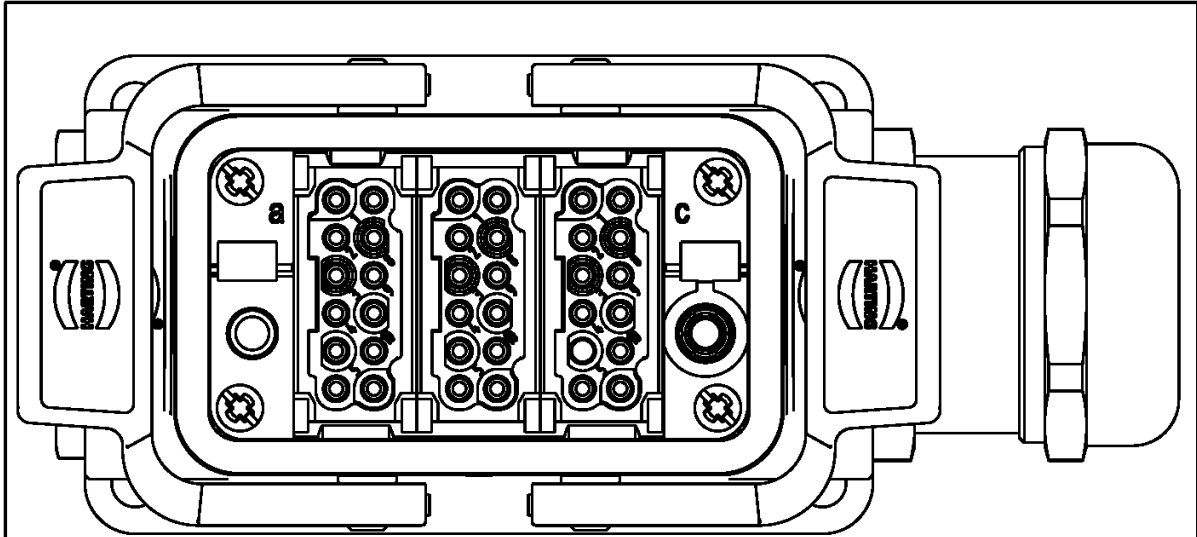

MODULE /PIN NO.	MACHINE WIRE NO.	I/O BLOCK/ PORT/PIN NO.	WIRE COLOR/ WIRE NO.	PUMP WIRE NO.	INPUT/OUTPUT FUNCTION	SIGNAL DESCRIPTION
A1	1	1/1/4	WHITE	162	OUTPUT TO VALVE 1, A PORT	24 VDC, 26 W, SOURCE TO SOLENOID
A2	2	1/1/2	GRY-PNK	164	OUTPUT TO VALVE 1, B PORT	24 VDC, 26 W, SOURCE TO SOLENOID
A3	3	1/3/4	YELLOW	170	OUTPUT TO VALVE 2, A PORT	24 VDC, 26 W, SOURCE TO SOLENOID
A4	4	1/3/2	WHT-GRN	172	OUTPUT TO VALVE 2, B PORT	24 VDC, 26 W, SOURCE TO SOLENOID
A5	5	-	BLACK / 2	110	OUTPUT TO E-STOP RELAY AI	24 VDC, SOURCE TO RELAY COIL
A6	6	1/ALL/1	BRN & BLK / 1	114	OUTPUT TO ALL VLVS & P.S. 24 VDC POWER	24 VDC, 120 WATTS MINIMUM
A7	7	1/2/4	GREEN	166	INPUT FROM PRESSURE SWITCH 1, A PORT	24 VDC, SOURCE TO PLC
A8	8	1/2/2	RED-BLU	168	INPUT FROM PRESSURE SWITCH 1, B PORT	24 VDC, SOURCE TO PLC
A9	9	1/4/4	GRAY	174	INPUT FROM PRESSURE SWITCH 2, A PORT	24 VDC, SOURCE TO PLC
A10	10	1/4/2	BRN-GRN	176	INPUT FROM PRESSURE SWITCH 2, B PORT	24 VDC, SOURCE TO PLC
A11	11	-	BLACK / 3	112	OUTPUT TO FAULT RESET RELAY AI	24 VDC, SOURCE TO RELAY COIL
A12	12	1/ALL/3	BLU & BLK / 8	116	OUTPUT TO ALL VLVS & P.S. COMMON	0 VDC
B1	13	1/5/4	PINK	178	OUTPUT TO VALVE 3, A PORT	24 VDC, 26 W, SOURCE TO SOLENOID
B2	14	1/5/2	WHT-YLW	180	OUTPUT TO VALVE 3, B PORT	24 VDC, 26 W, SOURCE TO SOLENOID
B3	15	1/7/4	BLACK	186	OUTPUT TO VALVE 4, A PORT	24 VDC, 26 W, SOURCE TO SOLENOID
B4	16	1/7/2	WHT-GRY	188	OUTPUT TO VALVE 4, B PORT	24 VDC, 26 W, SOURCE TO SOLENOID
B5	17	-	BLACK / 4	102	INPUT FROM LEVEL SWITCH RELAY AI	N/C RELAY CONTACT
B6	18	-	BLACK / 6	108	INPUT FROM FILTER CLOG SWITCH RELAY AI	N/C RELAY CONTACT
B7	19	1/6/4	RED	182	INPUT FROM PRESSURE SWITCH 3, A PORT	24 VDC, SOURCE TO PLC
B8	20	1/6/2	YLW-BRN	184	INPUT FROM PRESSURE SWITCH 3, B PORT	24 VDC, SOURCE TO PLC
B9	21	1/8/4	VIOLET	190	INPUT FROM PRESSURE SWITCH 4, A PORT	24 VDC, SOURCE TO PLC
B10	22	1/8/2	GRY-BRN	192	INPUT FROM PRESSURE SWITCH 4, B PORT	24 VDC, SOURCE TO PLC
B11	23	-	BLACK / 5	104	INPUT FROM TEMPERATURE SWITCH RELAY AI	N/C RELAY CONTACT
B12	24	-	BLACK / 7	106	INPUT FROM VFD FAULT SWITCH RELAY AI	N/C RELAY CONTACT FOR NO DRIVE FAULT
C1	25	2/1/4	WHITE	262	OUTPUT TO VALVE 5, A PORT	24 VDC, 26 W, SOURCE TO SOLENOID
C2	26	2/1/2	GRY-PNK	264	OUTPUT TO VALVE 5, B PORT	24 VDC, 26 W, SOURCE TO SOLENOID
C3	27	2/3/4	YELLOW	270	OUTPUT TO VALVE 6, A PORT	24 VDC, 26 W, SOURCE TO SOLENOID
C4	28	2/3/2	WHT-GRN	272	OUTPUT TO VALVE 6, B PORT	24 VDC, 26 W, SOURCE TO SOLENOID
C5	-	-	-	-	NONE	NONE
C6	29	2/ALL/1	BRN & BLK / 1	293	OUTPUT TO ALL VLVS & P.S. 24 VDC POWER	24 VDC, 180 WATTS MINIMUM
C7	30	2/2/4	GREEN	266	INPUT FROM PRESSURE SWITCH 5, A PORT	24 VDC, SOURCE TO PLC
C8	31	2/2/2	RED-BLU	268	INPUT FROM PRESSURE SWITCH 5, B PORT	24 VDC, SOURCE TO PLC
C9	32	2/4/4	GRAY	274	INPUT FROM PRESSURE SWITCH 6, A PORT	24 VDC, SOURCE TO PLC
C10	33	2/4/2	BRN-GRN	276	INPUT FROM PRESSURE SWITCH 6, B PORT	24 VDC, SOURCE TO PLC
C11	-	-	-	-	NONE	NONE
C12	35	2/ALL/3	BLU & BLK / 8	294	OUTPUT TO ALL VLVS & P.S. COMMON	0 VDC
GND	GRN-YLW	1/ALL/5	GRN-YLW	118	GROUND FOR ALL VALVE OUTPUTS	N/A

PL559567 REV B

SECTION V

PUMP OPERATION (continued)

d. Optimized 1-4 Valve Machine Tool Interface Control (with Power) See table below for pin out and description of function.

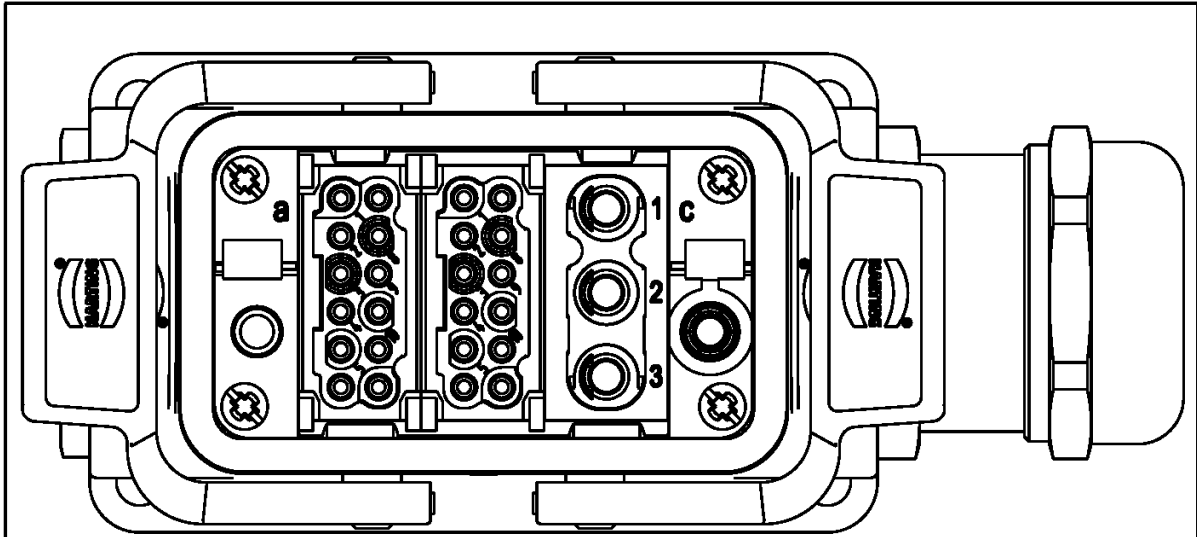

MODULE /PIN NO.	MACHINE WIRE NO.	I/O BLOCK/ PORT/PIN NO.	WIRE COLOR/ WIRE NO.	PUMP WIRE NO.	INPUT/OUTPUT FUNCTION	SIGNAL DESCRIPTION
A1	1	1/1/4	WHITE	162	OUTPUT TO VALVE 1, A PORT	24 VDC, 26 W, SOURCE TO SOLENOID
A2	2	1/1/2	GRY-PNK	164	OUTPUT TO VALVE 1, B PORT	24 VDC, 26 W, SOURCE TO SOLENOID
A3	3	1/3/4	YELLOW	170	OUTPUT TO VALVE 2, A PORT	24 VDC, 26 W, SOURCE TO SOLENOID
A4	4	1/3/2	WHT-GRN	172	OUTPUT TO VALVE 2, B PORT	24 VDC, 26 W, SOURCE TO SOLENOID
A5	5	-	BLACK / 2	110	OUTPUT TO E-STOP RELAY AI	24 VDC, SOURCE TO RELAY COIL
A6	6	1/ALL/1	BRN & BLK / 1	114	OUTPUT TO ALL VLVS & P.S. 24 VDC POWER	24 VDC, 120 WATTS MINIMUM
A7	7	1/2/4	GREEN	166	INPUT FROM PRESSURE SWITCH 1, A PORT	24 VDC, SOURCE TO PLC
A8	8	1/2/2	RED-BLU	168	INPUT FROM PRESSURE SWITCH 1, B PORT	24 VDC, SOURCE TO PLC
A9	9	1/4/4	GRAY	174	INPUT FROM PRESSURE SWITCH 2, A PORT	24 VDC, SOURCE TO PLC
A10	10	1/4/2	BRN-GRN	176	INPUT FROM PRESSURE SWITCH 2, B PORT	24 VDC, SOURCE TO PLC
A11	11	-	BLACK / 3	112	OUTPUT TO FAULT RESET RELAY AI	24 VDC, SOURCE TO RELAY COIL
A12	12	1/ALL/3	BLU & BLK / 8	116	OUTPUT TO ALL VLVS & P.S. COMMON	0 VDC
B1	13	1/5/4	PINK	178	OUTPUT TO VALVE 3, A PORT	24 VDC, 26 W, SOURCE TO SOLENOID
B2	14	1/5/2	WHT-YLW	180	OUTPUT TO VALVE 3, B PORT	24 VDC, 26 W, SOURCE TO SOLENOID
B3	15	1/7/4	BLACK	186	OUTPUT TO VALVE 4, A PORT	24 VDC, 26 W, SOURCE TO SOLENOID
B4	16	1/7/2	WHT-GRY	188	OUTPUT TO VALVE 4, B PORT	24 VDC, 26 W, SOURCE TO SOLENOID
B5	17	-	BLACK / 4	102	INPUT FROM LEVEL SWITCH RELAY AI	N/C RELAY CONTACT
B6	18	-	BLACK / 6	108	INPUT FROM FILTER CLOG SWITCH RELAY AI	N/C RELAY CONTACT
B7	19	1/6/4	RED	182	INPUT FROM PRESSURE SWITCH 3, A PORT	24 VDC, SOURCE TO PLC
B8	20	1/6/2	YLW-BRN	184	INPUT FROM PRESSURE SWITCH 3, B PORT	24 VDC, SOURCE TO PLC
B9	21	1/8/4	VIOLET	190	INPUT FROM PRESSURE SWITCH 4, A PORT	24 VDC, SOURCE TO PLC
B10	22	1/8/2	GRY-BRN	192	INPUT FROM PRESSURE SWITCH 4, B PORT	24 VDC, SOURCE TO PLC
B11	23	-	BLACK / 5	104	INPUT FROM TEMPERATURE SWITCH RELAY AI	N/C RELAY CONTACT
B12	24	-	BLACK / 7	106	INPUT FROM VFD FAULT SWITCH RELAY AI	N/C RELAY CONTACT FOR NO DRIVE FAULT
C1	L1	-	BLACK	L1	OUTPUT POWER LINE 1 TO PUMP ENCLOSURE	100-120/200-230/380-500 VAC, 20/7/4 A
C2	L2	-	WHITE	L2	OUTPUT POWER LINE 2 TO PUMP ENCLOSURE	100-120/200-230/380-500 VAC, 20/7/4 A
C3	L3	-	RED	L3	OUTPUT POWER LINE 3 TO PUMP ENCLOSURE	100-120/200-230/380-500 VAC, 20/7/4 A
GND	GRN-YLW	-	GREEN	GND	GROUND FOR POWER	N/A

PL559568 REV B

e. I/O block for the 1-4 valve machine tool interface control is located on the right-hand side of the back of the electrical enclosure mounting panel. It allows for the CNC machine to individually control 1, 2, 3, or 4 valves and monitor 1 or 2 pressure switches for each of these valves in the stack. Each valve is connected to the left-hand M12 I/O block port and each pressure switch(s) is connected to the right-hand M12 I/O block port.

IMPORTANT 24VDC power must be supplied by the CNC Machine Tool PLC. See illustration below for pin out and description of I/O function.

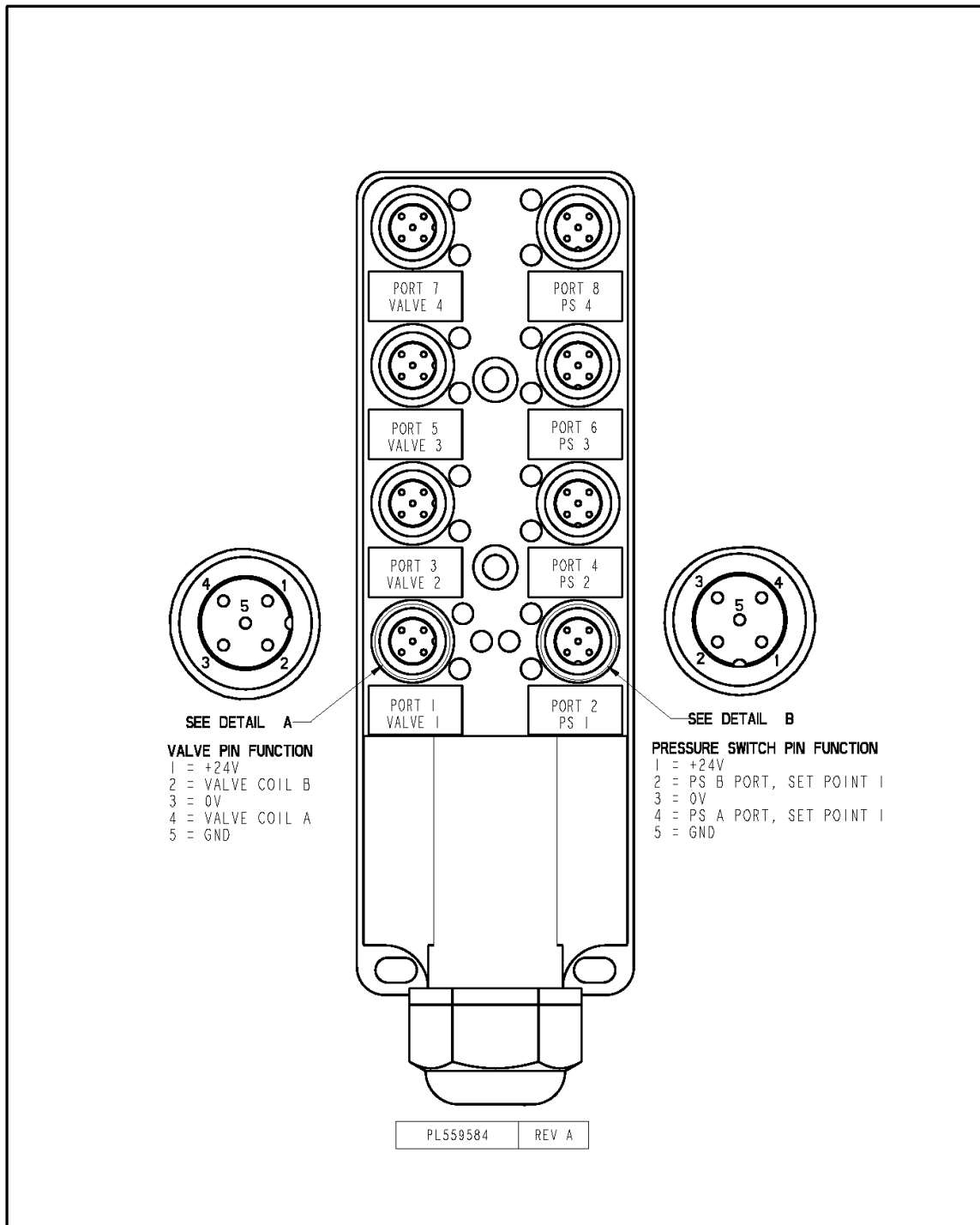

f. I/O block for the 5-6 valve machine tool interface control is located on the left-hand side of the back of the electrical enclosure mounting panel. It allows for the CNC machine to individually control 5 or 6 valves and monitor 1 or 2 pressure switches for each of these valves in the stack. Each valve is connected to the left-hand M12 I/O block port and each pressure switch(s) is connected to the right-hand M12 I/O block port. M12 ports 5, 6, 7, 8 are not used. **IMPORTANT** 24VDC power must be supplied by the CNC Machine Tool PLC. See illustration below for pin out and description of I/O function.

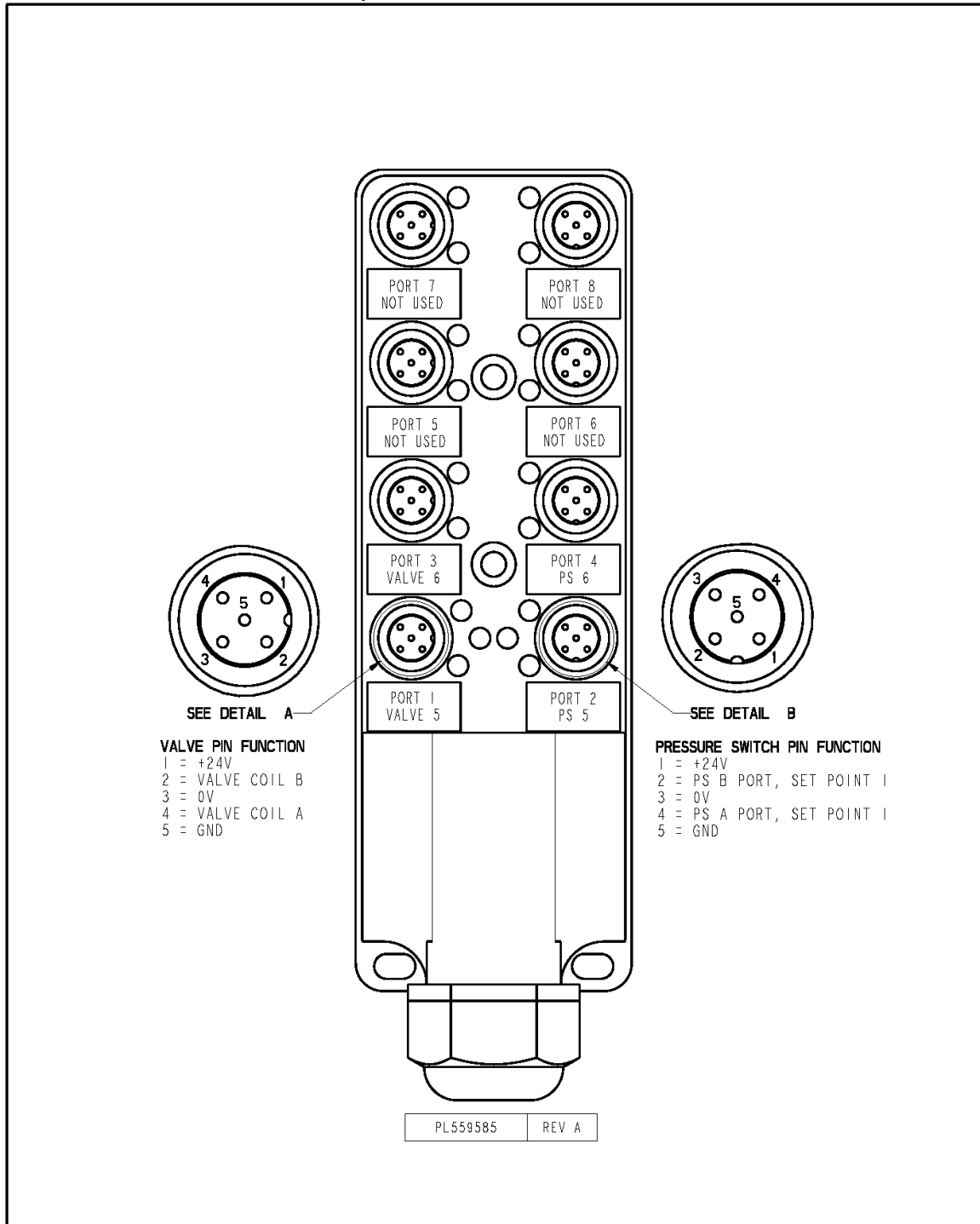

SECTION V

PUMP OPERATION (continued)

8. Machine Tool Interface Control Operated Pump – Okuma Ethernet

- a. Complete integration of the pump, valves, and pressure switches to the Okuma CNC machine can be accomplished with 1 of 2 Ethernet options, a 1-4 valve system, or a 5-6 valve system. The Vektek AWP App (Okuma Thinc App) is installed in the control system which allows for seamless communication between the CNC machine and the pump. Each pump is supplied with a 16 ft (5M) Ethernet cable to be connected to the CNC network. The pump is also supplied with a 16 ft (5M) M12 cable for external E-Stop that is prewired to the pump enclosure for complete control. A jumper is supplied if the E-Stop cable is not connected to the CNC machine. Input pump status monitoring for each configuration includes oil level, oil temperature, oil filter clog indicator, and VFD fault status. Output commands from the Okuma part program controls all valve and optional components while monitoring all pressure switches in each hydraulic circuit. This allows for complete control and monitoring of the pump system for all configurations. Setup and monitoring of all pump functions is done via browser interface window on the Okuma CNC machine control screen. **IMPORTANT** See PL5595-MCE operations manual for all Vektek AWP App setup and control. All Machine Tool Interface Control options must be configured at the time of order and built at the factory. These options cannot be added or upgraded in the field.

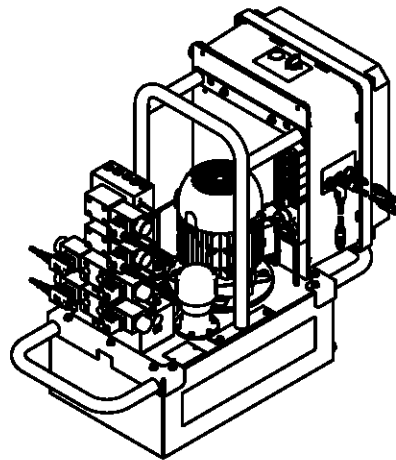

SOLENOID VALVES 1-4
MACHINE INTERFACE CONTROL ETHERNET

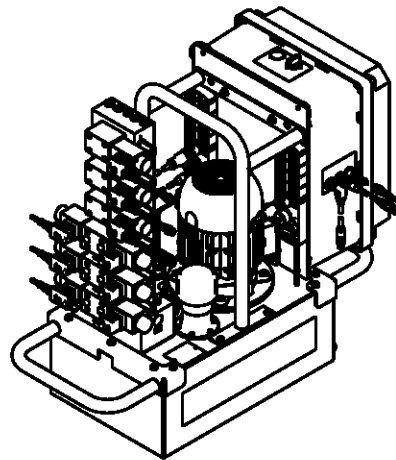

SOLENOID VALVES 5-6
MACHINE INTERFACE CONTROL ETHERNET

- b. I/O block for the 1-4 valve machine tool interface control is located on the right-hand side of the back of the electrical enclosure mounting panel. It allows for the CNC machine to individually control 1, 2, 3, or 4 valves or components and monitor 1 or 2 pressure switches for each of these valves or components in the stack. Each valve or component is connected to the left-hand M12 I/O block port and each related pressure switch is connected to the right-hand M12 I/O block port. Power and Ethernet BUS cables must be connected as shown in the illustration below. **IMPORTANT** The 10 Bit Dip Switch must set 1 to ON - Up. See Operations manual for programming procedures.

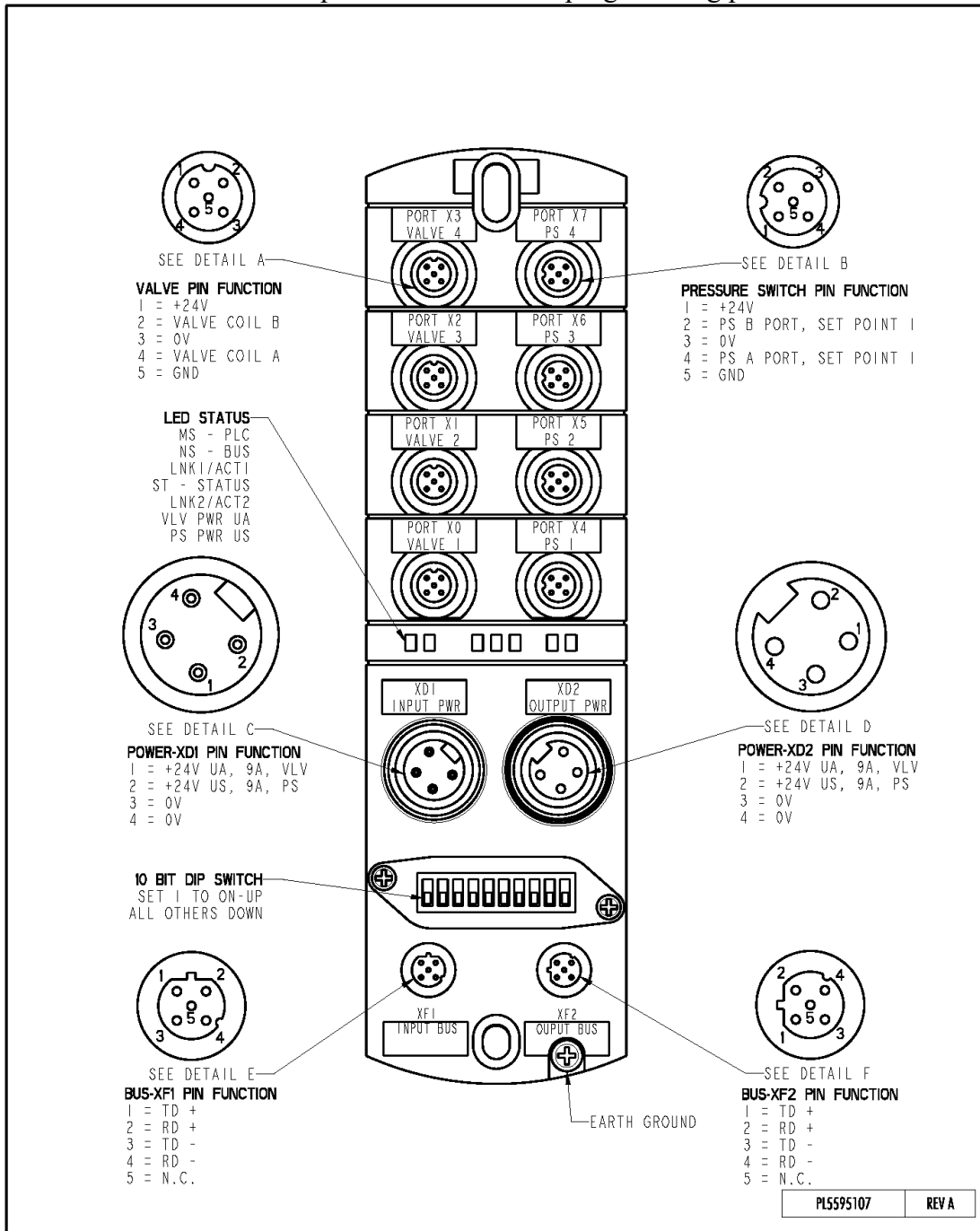

- c. I/O block for the 5-6 valve machine tool interface control is located on the left-hand side of the back of the electrical enclosure mounting panel. It allows for the CNC machine to individually control 5 or 6 valves or components and monitor 1 or 2 pressure switches for each of these valves or components in the stack. It also allows for control of a 7th or 8th optional component such as part confirmation valves and monitoring of related air sensing pressure switches. Each valve or component is connected to the left-hand M12 I/O block port and each pressure switch is connected to the right-hand M12 I/O block port. Power and Ethernet BUS cables must be connected as shown in the illustration below. **IMPORTANT** The 10 Bit Dip Switch must set 2 to ON - Up. See Operations manual for programming procedures.

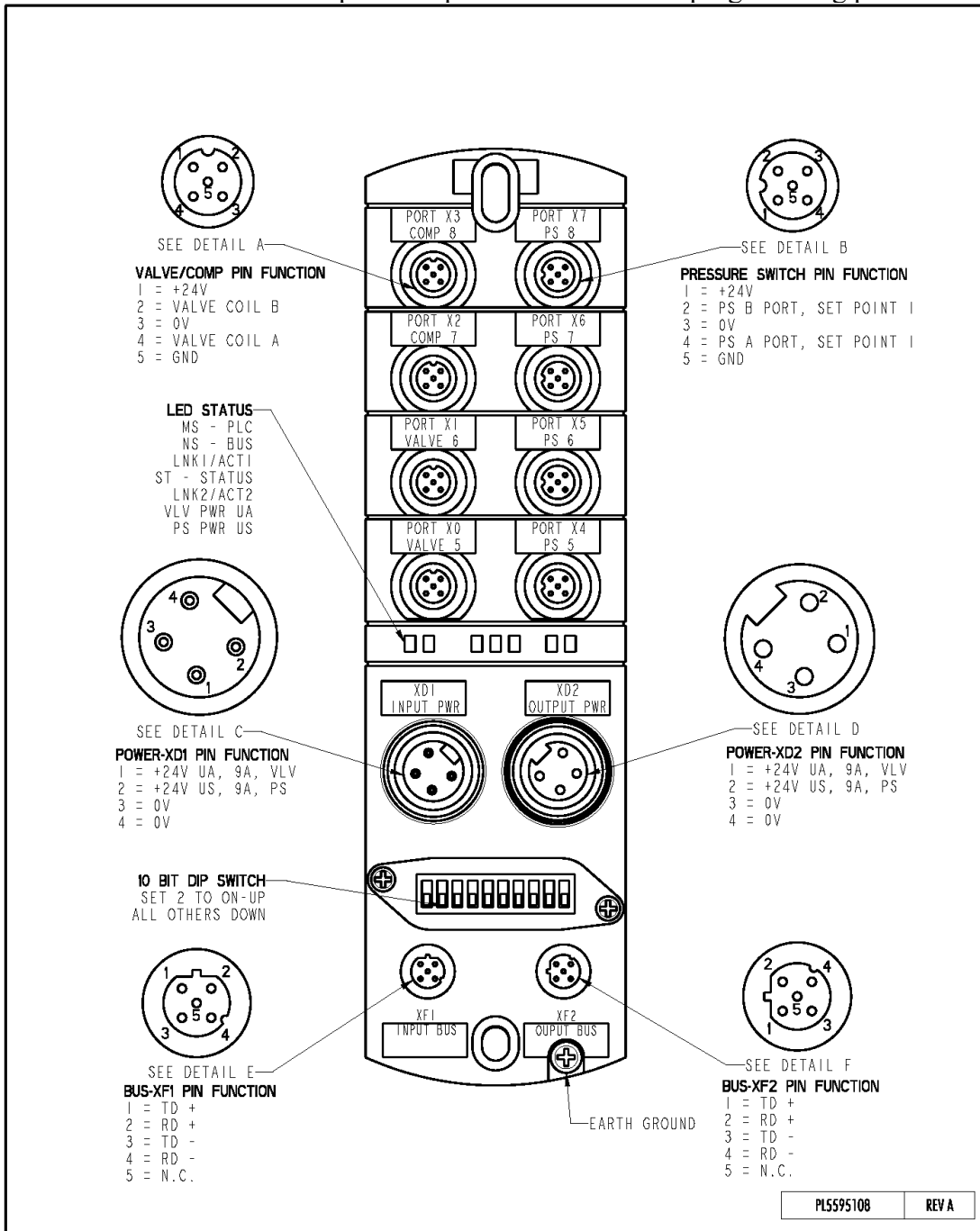

SECTION V

PUMP OPERATION (continued)

9. Machine Tool Interface Control Operated Pump – HMI Ethernet

- a. Complete integration of the pump, valves, and pressure switches to the CNC machine can be accomplished with 1 of 2 Ethernet options, a 1-4 valve system, or a 5-6 valve system. Each pump is supplied with a 16 ft (5M) Ethernet cable and an I/O Station or Stations as required to be connected to the CNC Control System or input/output relays for optional M-codes. The pump is also supplied with a 16 ft (5M) M12 cable for external E-Stop that is prewired to the pump enclosure for complete control. A jumper is supplied if the E-Stop cable is not connected to the CNC machine. Input pump status monitoring for each configuration includes oil level, oil temperature, oil filter clog indicator, and VFD fault status. Output M-code commands from the CNC part program controls all valve and optional components while acknowledging pressure switches in each hydraulic circuit. This allows for complete control and monitoring of the pump system for all configurations. Setup and monitoring of all pump functions are done via browser interface window on the supplied HMI screen. **IMPORTANT** See PL5595-MCE-HMI operations manual for all Vektek AWP setup and control. All Machine Tool Interface Control options must be configured at the time of order and built at the factory. These options cannot be added or upgraded in the field.

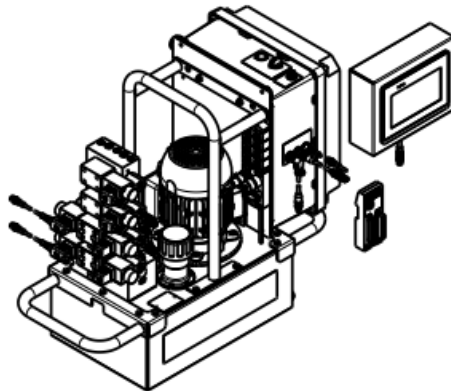

SOLENOID VALVES 1-4
MACHINE INTERFACE CONTROL HMI ETHERNET

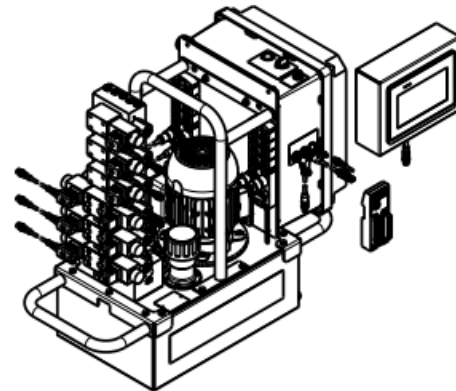

SOLENOID VALVES 5-6
MACHINE INTERFACE CONTROL HMI ETHERNET

- b. I/O block for the 1-4 valve machine tool interface control is the same as described in Section 8.b.
- c. I/O block for the 5-6 valve machine tool interface control is the same as described in Section 8.c.

- d. The I/O Station for the machine tool interface control is to be located in the CNC machine enclosure if required. It allows for the CNC machine to communicate system status, control all valves or components, and acknowledge all pressure switches in the stack. Additional IO Stations can be added for control of Jobs within the CNC part program and to call up saved part programs in the AWP PLC program. **IMPORTANT:** The Modes of Operation Rotary Switches must be set to 500 for station program mode. See Operations manual and/or IS5506 for programming procedures.

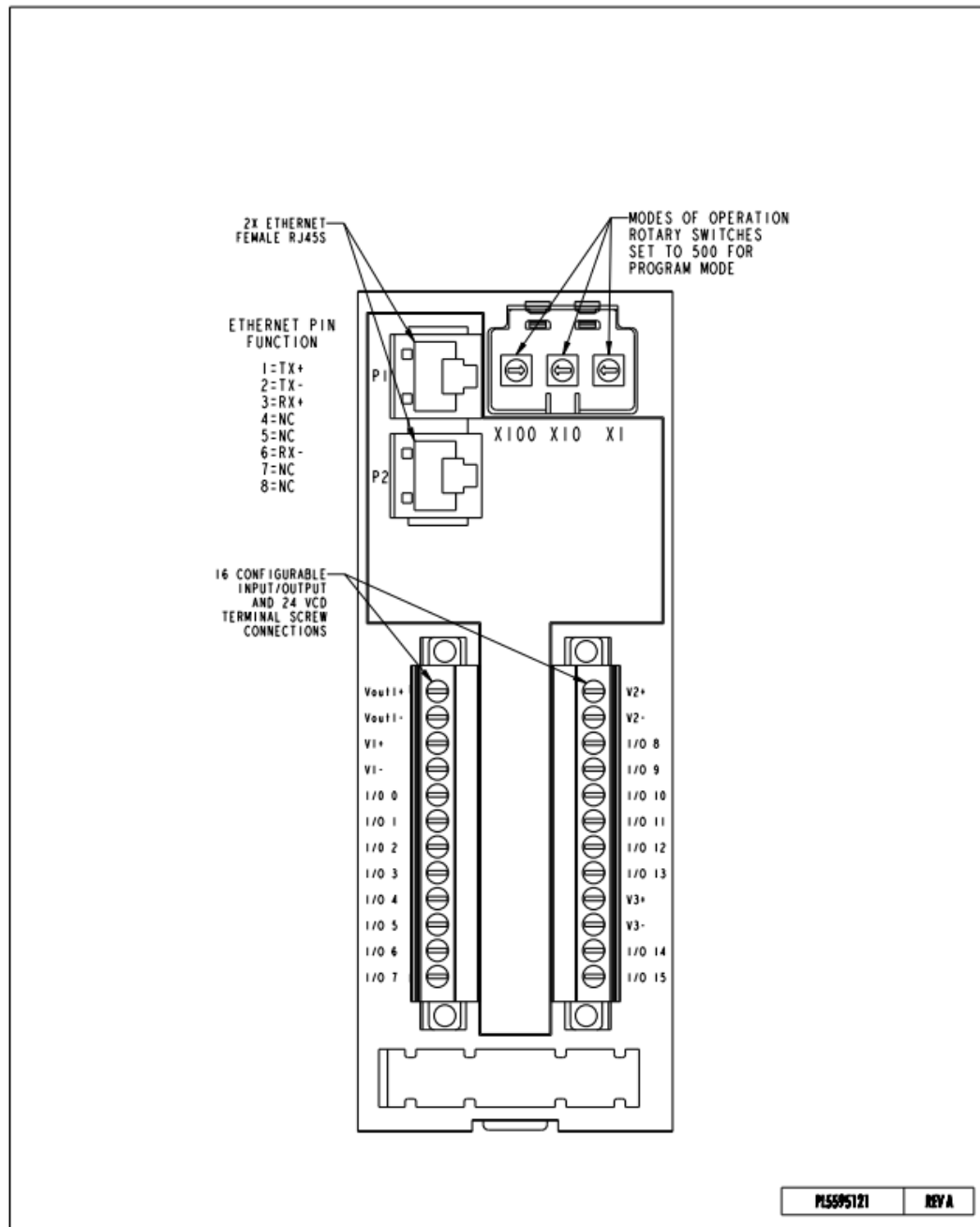

SECTION VI

MAINTENANCE

WARNING

Disconnect electric power to the pump **BEFORE** performing any maintenance. **DO NOT** connect or disconnect from the pump while under pressure. First turn the pump motor off. Then slowly shift the valve through all positions to completely depressurize the system. Check gage(s) to verify that all system pressure has been relieved. Failure to follow this warning may result in property damage or bodily injury.

CAUTION

ALWAYS clean dirt and other contaminants from the pump before any maintenance is performed to prevent contamination from entering the system.

CAUTION

NEVER mix different grades of oil. Completely drain and flush system of oil and refill with new grade if deemed necessary.

A. INTERVALS

1.0 Daily

- a. Check oil level. Oil should be approximately ½” below the top plate of the reservoir with all devices retracted.
- b. Check hoses, tubing, fittings, and quick couplers for damage and wear. Replace as necessary.
- c. Check for damaged electrical connectors and cords. **DO NOT** operate the pump if damage is found.

2.0 Monthly

- a. Remove and clean the bronze full flow filter, Vektek p/n 31-0910-05, see parts list section for location. Clean the filter from the inside out using a non-flammable solvent and drying with air. Make sure the o-ring is in the proper place when re-assembling. Torque the spring retainer per note. If the filter shows signs of wear, stress, fracture, or cannot be satisfactorily cleaned, replace with a new filter.

WARNING

DO NOT operate the pump without the filter installed. Damage may result and will void warranty.

- b. Wipe the pump off to keep it clean. Dirt and grime accumulation contribute to overheating of the motor and oil.

SECTION VI

MAINTENANCE (continued)

3.0 Every 6 Months

- a. Change oil.
 - i. Drain the oil using the reservoir drain plug.
 - ii. Remove the motor pump assembly from the reservoir by removing the top plate bolts.
 - iii. Remove the suction screen from the bottom of the pump. Clean with a non-flammable solvent and air. Reinstall the suction screen.
 - iv. Reassemble the motor pump assembly to the reservoir.
 - v. Refill the reservoir with the correct grade of oil to approximately ½” below the top plate with devices retracted.

If system contamination is suspected, drain, clean, and refill the reservoir as described above. Operate the pump in a no load condition for a maximum of one minute. Then drain and refill the reservoir. Check for normal operation.

SECTION VI

MAINTENANCE (continued)

B. PARTS LISTS FOR AWP VALVE AND CONTROL CONFIGURATIONS

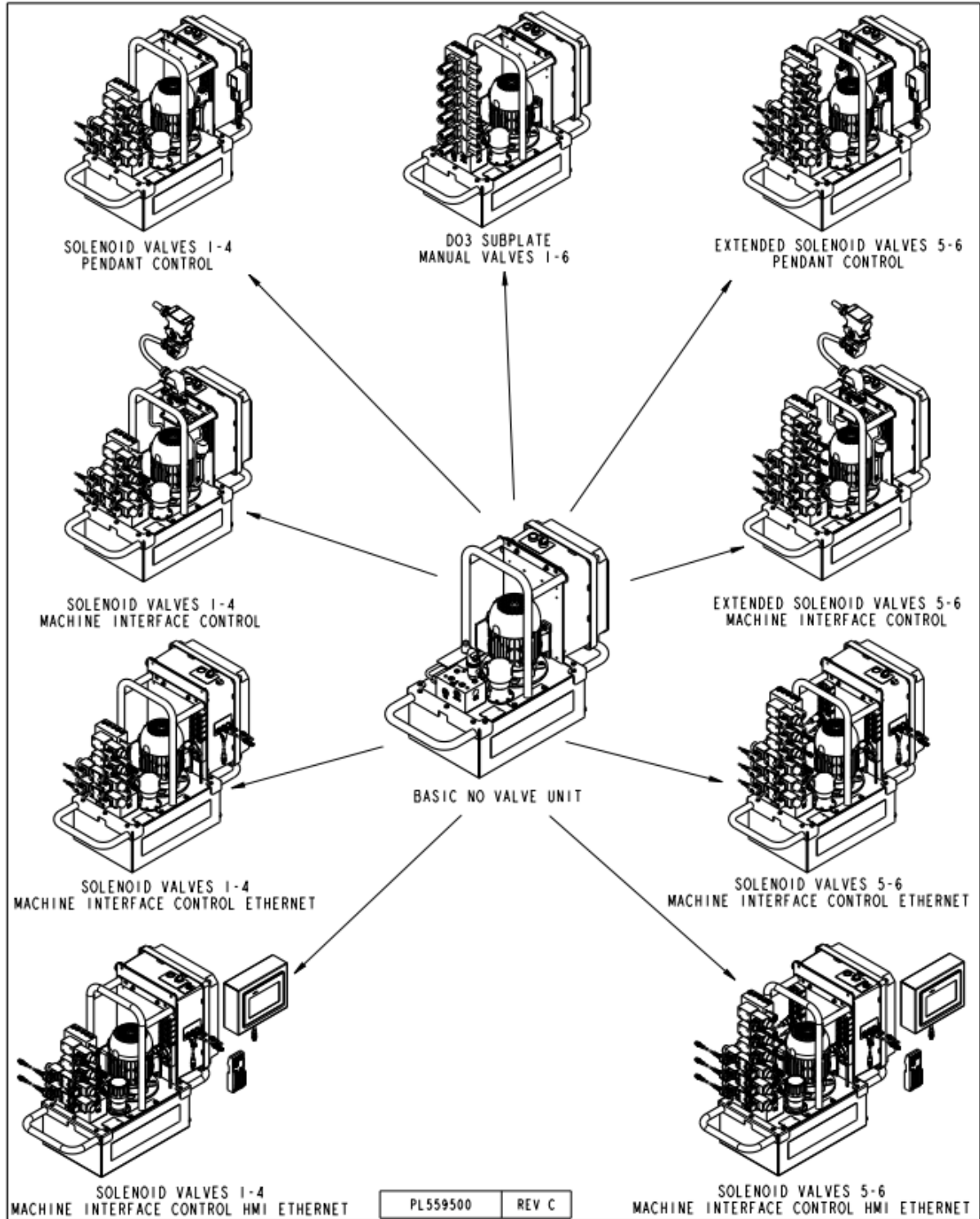

SECTION VI

MAINTENANCE (continued)

1.0 FINAL ASSEMBLY, NO VALVE, D03 STACK BLOCK, MANUAL VALVE

NO	QTY	PART NO	DESCRIPTION
N/A	N/A	5595X500	AY, AWP, 50, 5G, NP
N/A	N/A	5595X501	AY, AWP, 50, 5G, D03
N/A	N/A	5595X51X	AY, AWP, 50, 5G, MNL
1	3	21410007	SCREW, CAP, SOCH, 3/8-16 X 3-1/4, ALY
2	3	21410018	SCREW, CAP, SOCH, 3/8-16 X 6, ALY
3	3	21410042	SHCS, 3/8-16 X 9
4	3	21410043	SHCS, 3/8-16 X 12
5	3	21410078	ASSY, CAPSCREW, 3/8-16 X 15.00
6	2	21410092	PIN, DRIVE, #2-8 X 1/4
7	1	67040077	PLATE, NAME, BLANK, HOLE MNT
8	1	95595009	ASSY, FILTER, VISUAL CLOG INDICATOR
9	1	95595010	ASSY, FILTER, ELEC CLOG INDICATOR
10	1	95595013	ASSY, COVER, NO RETRUN LINE FILTER
11	1	95595500	ASSY, SWITCH, LEVEL, PUMP, 5 GAL
12	1	95595501	ASSY, SWITCH, LEVEL, TEMP, PUMP, 5 GAL
13	3	S2141000	ASSY, CAPSCREW, 3/8-16 X 17.93

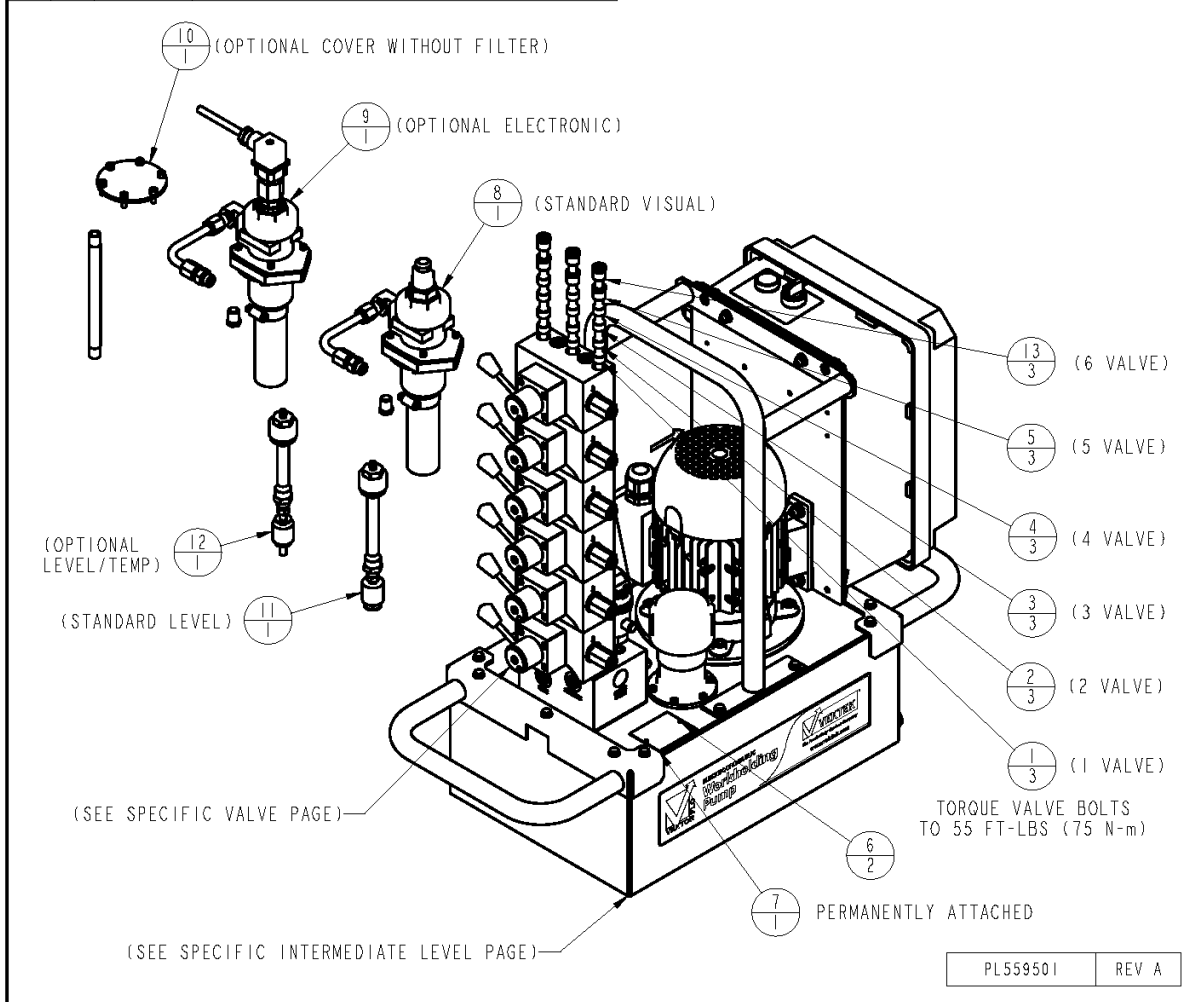

SECTION VI

MAINTENANCE (continued)

2.0 FINAL ASSEMBLY, SOLENOID, 1-4 VALVE, PENDANT CONTROL

NO	QTY	PART NO	DESCRIPTION
N/A	N/A	5595X52X	AY, AWP, 50, 5G, 24V, 1-4 VLV
1	3	21410007	SCREW, CAP, SOCH, 3/8-16 X 3-1/4, ALY
2	3	21410018	SCREW, CAP, SOCH, 3/8-16 X 6, ALY
3	3	21410042	SHCS, 3/8-16 X 9
4	3	21410043	SHCS, 3/8-16 X 12
5	2	21410092	PIN, DRIVE, #2-8 X 1/4
6	1	67040077	PLATE, NAME, BLANK, HOLE MNT
7	1	95595009	ASSY, FILTER, VISUAL CLOG INDICATOR
8	1	95595010	ASSY, FILTER, ELEC CLOG INDICATOR
9	1	95595013	ASSY, COVER, NO RETRUN LINE FILTER
10	1	95595500	ASSY, SWITCH, LEVEL, PUMP, 5 GAL
11	1	95595501	ASSY, SWITCH, LEVEL, TEMP, PUMP, 5 GAL

PL559502	REV A
----------	-------

SECTION VI

MAINTENANCE (continued)

3.0 FINAL ASSEMBLY, SOLENOID, 5-6 VALVE, PENDANT CONTROL

NO	QTY	PART NO	DESCRIPTION
N/A	N/A	5595X52X	AY, AWP, 50, 5G, 24V, 5-6 VLV
1	3	21410078	ASSY, CAPSCREW, 3/8-16 X 15.00
2	2	21410092	PIN, DRIVE, #2-8 X 1/4
3	1	67040077	PLATE, NAME, BLANK, HOLE MNT
4	1	95595009	ASSY, FILTER, VISUAL CLOG INDICATOR
5	1	95595010	ASSY, FILTER, ELEC CLOG INDICATOR
6	1	95595013	ASSY, COVER, NO RETRUN LINE FILTER
7	1	95595500	ASSY, SWITCH, LEVEL, PUMP, 5 GAL
8	1	95595501	ASSY, SWITCH, LEVEL, TEMP, PUMP, 5 GAL
9	3	S2141000	ASSY, CAPSCREW, 3/8-16 X 17.93

PL559503

REV A

SECTION VI

MAINTENANCE (continued)

4.0 FINAL ASSEMBLY, SOLENOID, 1-4 VALVE, MACHINE INTERFACE CONTROL

NO	QTY	PART NO	DESCRIPTION
N/A	N/A	5595X52X	AY, AWP, 50, 5G, 24V, 1-4 VLV, MC
1	3	21410007	SCREW, CAP, SOCH, 3/8-16 X 3-1/4, ALY
2	3	21410018	SCREW, CAP, SOCH, 3/8-16 X 6, ALY
3	3	21410042	SHCS, 3/8-16 X 9
4	3	21410043	SHCS, 3/8-16 X 12
5	2	21410092	PIN, DRIVE, #2-8 X 1/4
6	1	67040077	PLATE, NAME, BLANK, HOLE MNT
7	1	95595010	ASSY, FILTER, ELEC CLOG INDICATOR
8	1	95595501	ASSY, SWITCH, LEVEL, TEMP, PUMP, 5 GAL
9	1	95595524	ASSY, CONNECTOR, FEMALE, MC
10	1	95595617	ASSY, CONNECTOR, FEMALE, MC, PWR

(SEE SPECIFIC VALVE PAGE)

(SEE SPECIFIC INTERMEDIATE LEVEL PAGE)

TORQUE VALVE BOLTS
TO 55 FT-LBS (75 N-m)

PERMANENTLY ATTACHED

PL559504	REV B
----------	-------

SECTION VI

MAINTENANCE (continued)

5.0 FINAL ASSEMBLY, SOLENOID, 5-6 VALVE, MACHINE INTERFACE CONTROL

NO	QTY	PART NO	DESCRIPTION
N/A	N/A	5595X52X	AY, AWP, 50, 5G, 24V, 5-6 VLV, MC
1	3	21410078	ASSY, CAPSCREW, 3/8-16 X 15.00
2	2	21410092	PIN, DRIVE, #2-8 X 1/4
3	1	67040077	PLATE, NAME, BLANK, HOLE MNT
4	1	95595010	ASSY, FILTER, ELEC CLOG INDICATOR
5	1	95595501	ASSY, SWITCH, LEVEL, TEMP, PUMP, 5 GAL
6	1	95595603	AY, CONNECTOR, FEMALE, MC, XV
7	3	52141000	ASSY, CAPSCREW, 3/8-16 X 17.93

(SEE SPECIFIC VALVE PAGE)

(SEE SPECIFIC INTERMEDIATE LEVEL PAGE)

TORQUE VALVE BOLTS TO 55 FT-LBS (75 N-m)

PERMANENTLY ATTACHED

PL559505	REV B
----------	-------

SECTION VI

MAINTENANCE (continued)

6.0 FINAL ASSEMBLY, SOLENOID, 1-4 VALVE, MACHINE INTERFACE CONTROL, OKUMA ETHERNET

NO	QTY	PART NO	DESCRIPTION
N/A	N/A	N/A	AY, AWP, 50, 5G, 24V, 1-4 VLV, MCE
1	3	21410007	SCREW, CAP, SOCH, 3/8-16 X 3-1/4, ALY
2	3	21410018	SCREW, CAP, SOCH, 3/8-16 X 6, ALY
3	3	21410042	SHCS, 3/8-16 X 9
4	3	21410043	SHCS, 3/8-16 X 12
5	2	21410092	PIN, DRIVE, #2-8 X 1/4
6	1	67040077	PLATE, NAME, BLANK, HOLE MNT
7	1	95595010	ASSY, FILTER, ELEC CLOG INDICATOR
8	1	95595501	ASSY, SWITCH, LEVEL, TEMP, PUMP, 5 GAL

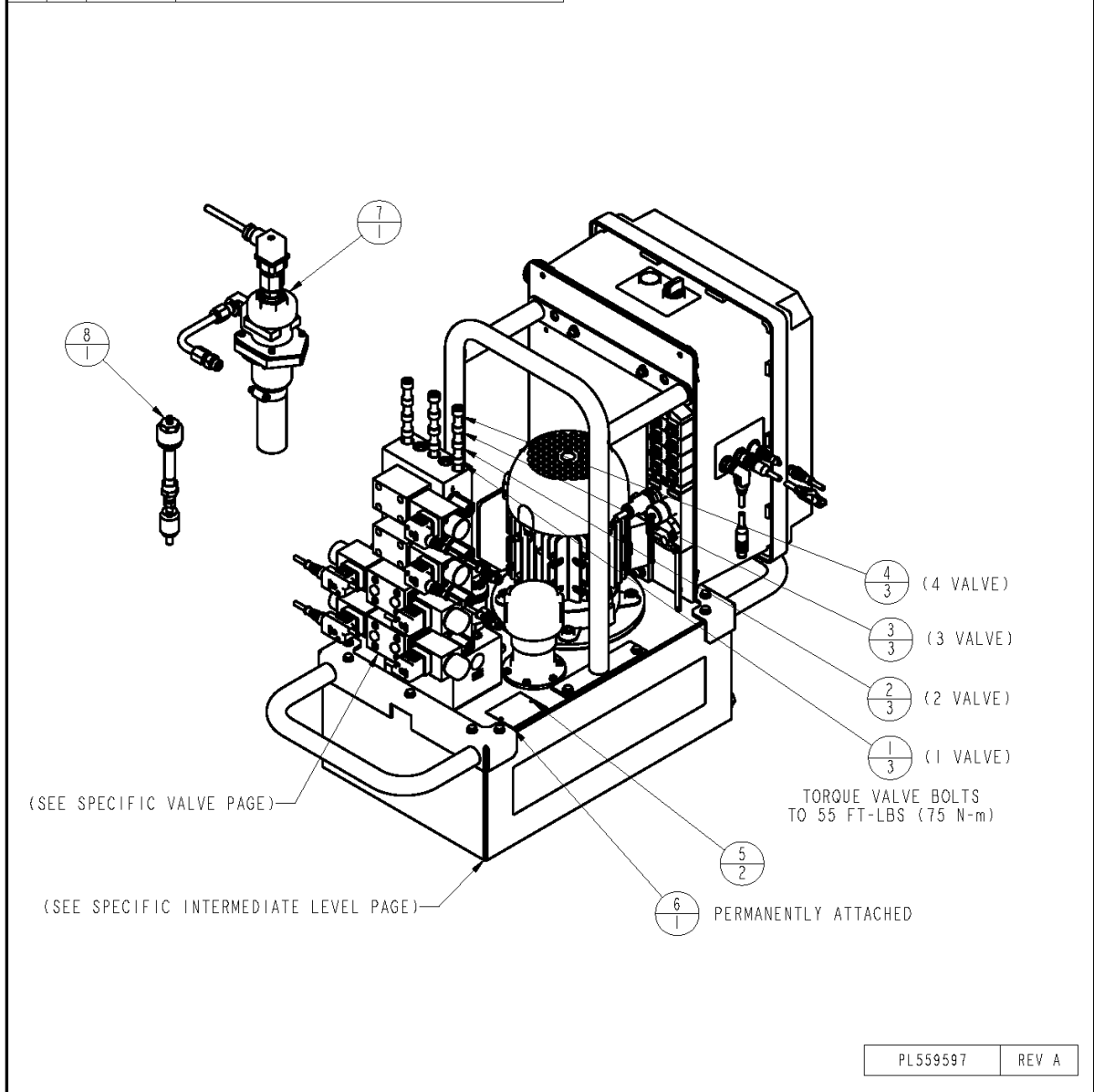

SECTION VI

MAINTENANCE (continued)

7.0 FINAL ASSEMBLY, SOLENOID, 5-6 VALVE, MACHINE INTERFACE CONTROL, OKUMA ETHERNET

NO	QTY	PART NO	DESCRIPTION
N/A	N/A	N/A	AY, AWP, 50, 5G, 24V, 5-6 VLV, MCE
1	3	21410078	ASSY, CAPSCREW, 3/8-16 X 15.00
2	2	21410092	PIN, DRIVE, #2-8 X 1/4
3	1	67040077	PLATE, NAME, BLANK, HOLE MNT
4	1	95595010	ASSY, FILTER, ELEC CLOG INDICATOR
5	1	95595501	ASSY, SWITCH, LEVEL, TEMP, PUMP, 5 GAL
6	3	S2141000	ASSY, CAPSCREW, 3/8-16 X 17.93

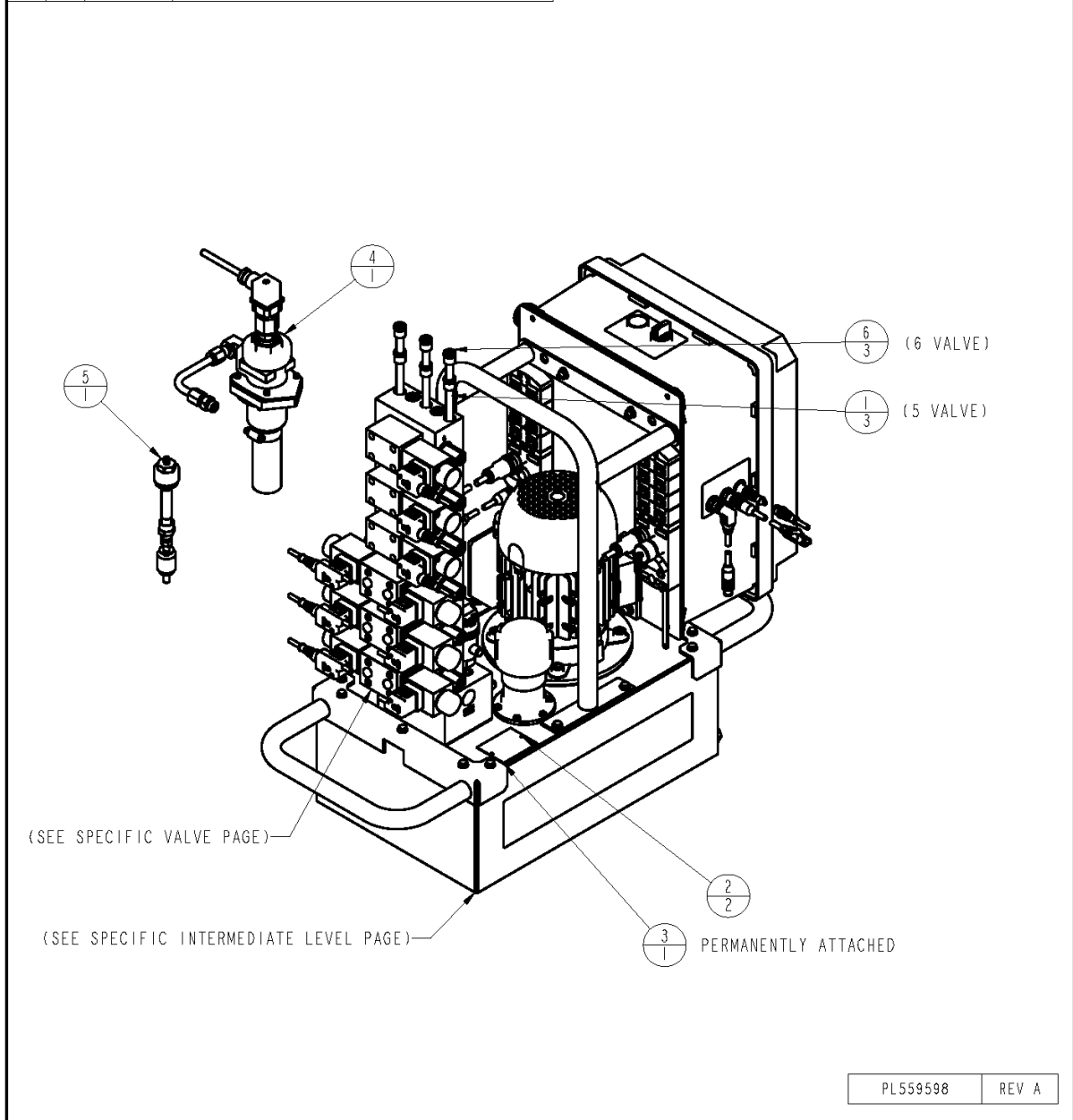

SECTION VI

MAINTENANCE (continued)

8.0 FINAL ASSEMBLY, SOLENOID, 1-4 VALVE, MACHINE INTERFACE CONTROL, HMI ETHERNET

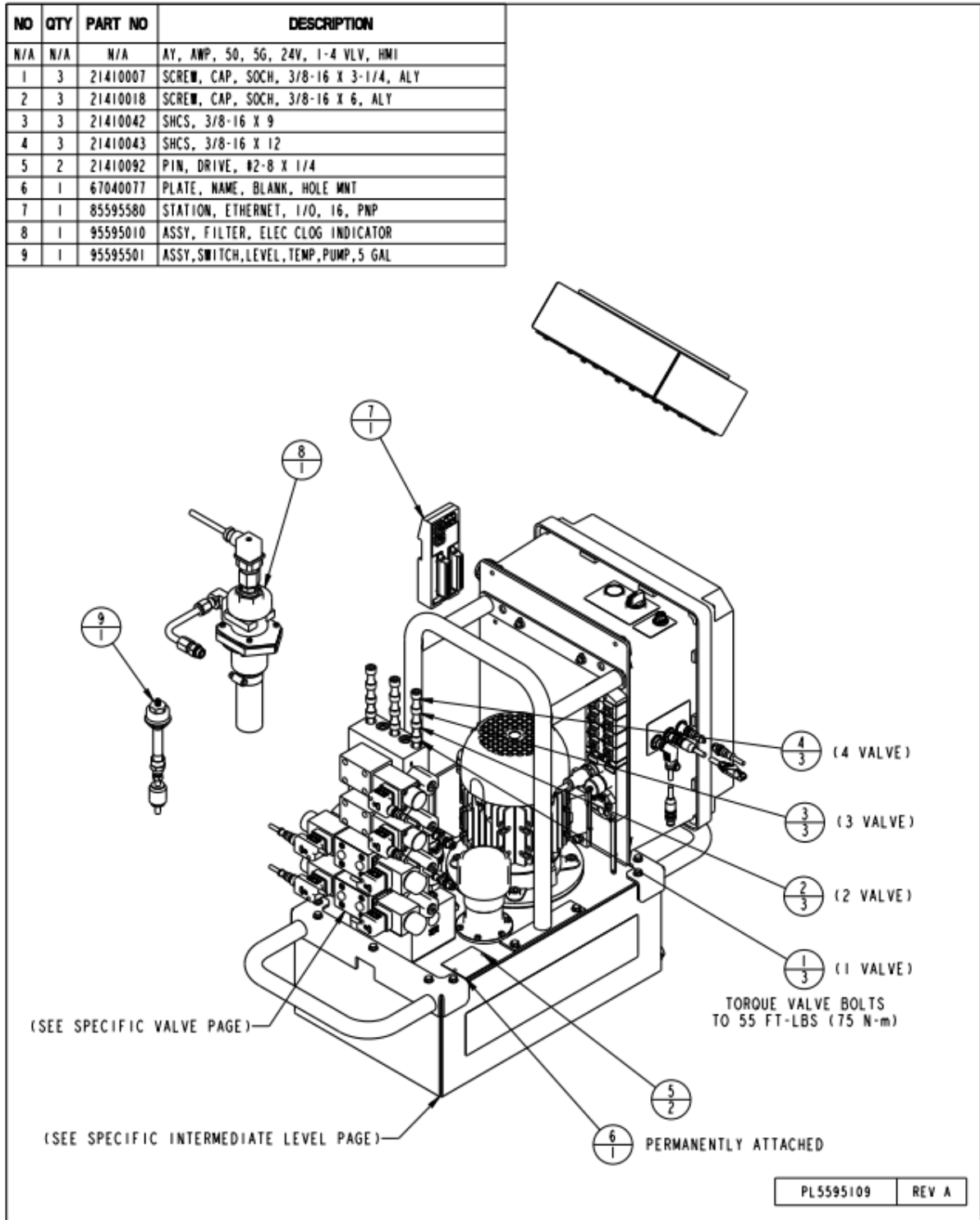

SECTION VI

MAINTENANCE (continued)

9.0 FINAL ASSEMBLY, SOLENOID, 5-6 VALVE, MACHINE INTERFACE CONTROL, HMI ETHERNET

NO	QTY	PART NO	DESCRIPTION
N/A	N/A	N/A	AV, ANP, 50, 5G, 24V, 5-6 VLV, HMI
1	3	21410078	ASSY, CAPSCREW, 3/8-16 X 15.00
2	2	21410092	PIN, DRIVE, #2-8 X 1/4
3	3	21410128	ASSY,CAPSCREW,3/8-16 X 17.93
4	1	67040077	PLATE, NAME, BLANK, HOLE MNT
5	1	85595580	STATION, ETHERNET, I/O, 16, PNP
6	1	95595010	ASSY, FILTER, ELEC CLOG INDICATOR
7	1	95595501	ASSY,SWITCH,LEVEL,TEMP,PUMP,5 GAL

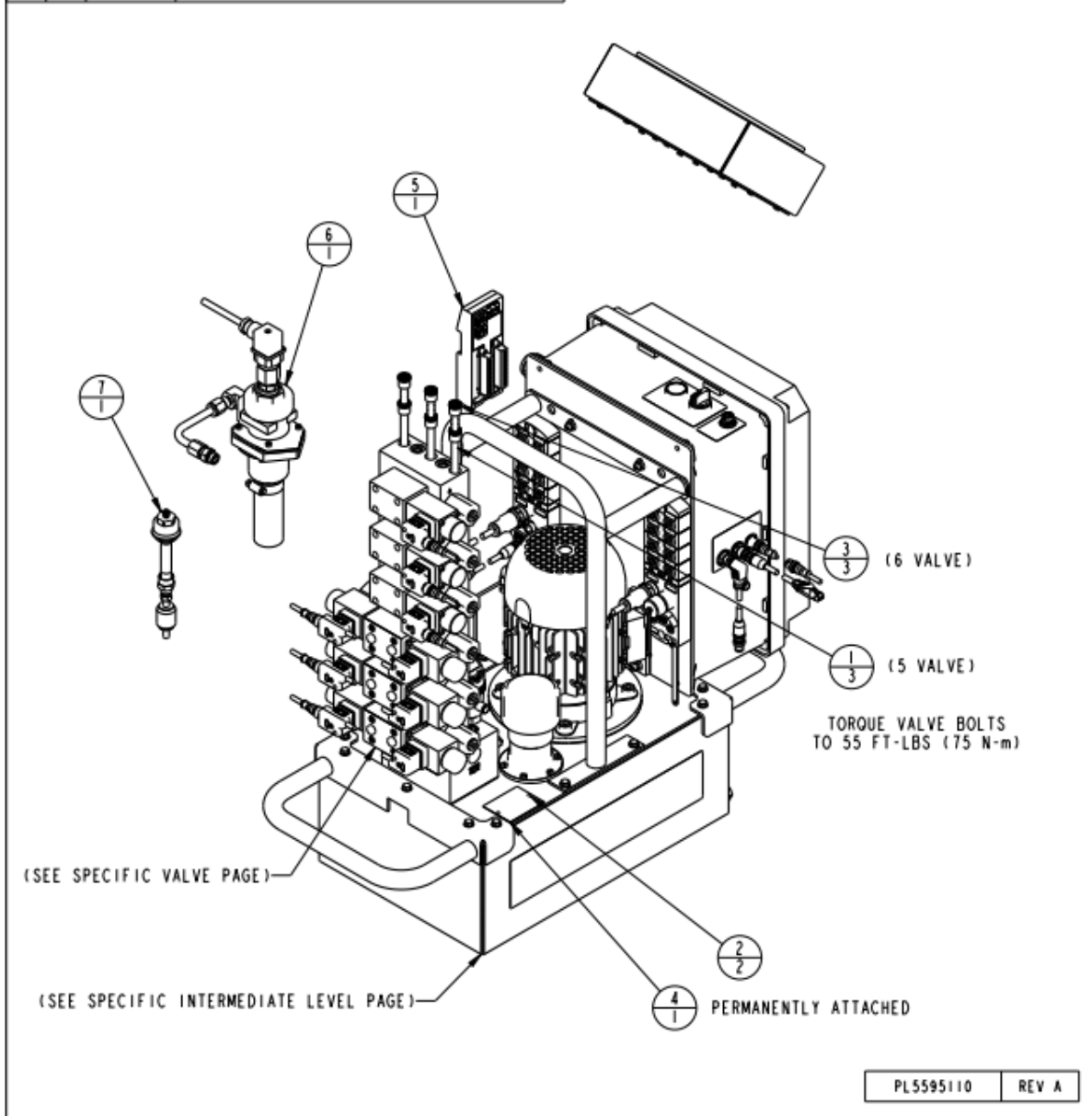

SECTION VI

MAINTENANCE (continued)

10.0 FINAL ASSEMBLY, MACHINE INTERFACE CONTROL, HMI ETHERNET, CART DESK MOUNT, CNC WALL MOUNT, 5M CABLE

NO	QTY	PART NO	DESCRIPTION
1	1	27742217	CABLE, HYBRID, CAT5, PWR, 8-PIN, SHIELD, 5M
2	1	62559500	KIT, CART, PUMP, AWP
3	1	85595581	MOUNT, MONITOR, DESK
4	1	85595582	MOUNT, MONITOR, WALL

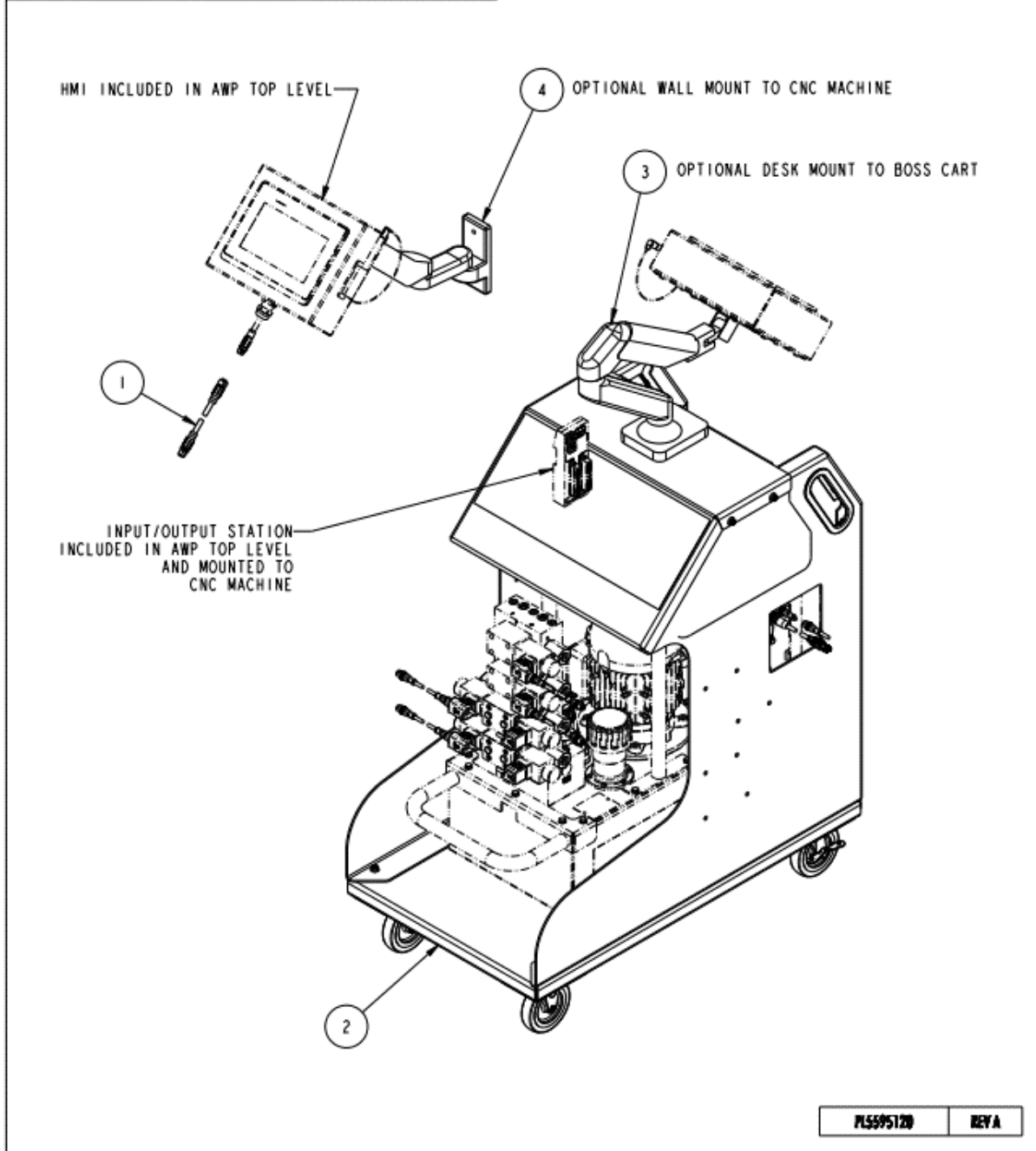

SECTION VI

MAINTENANCE (continued)

11.0 INTERMEDIATE ASSEMBLY, NO VALVE, D03 SUBPLATE, MANUAL VALVE

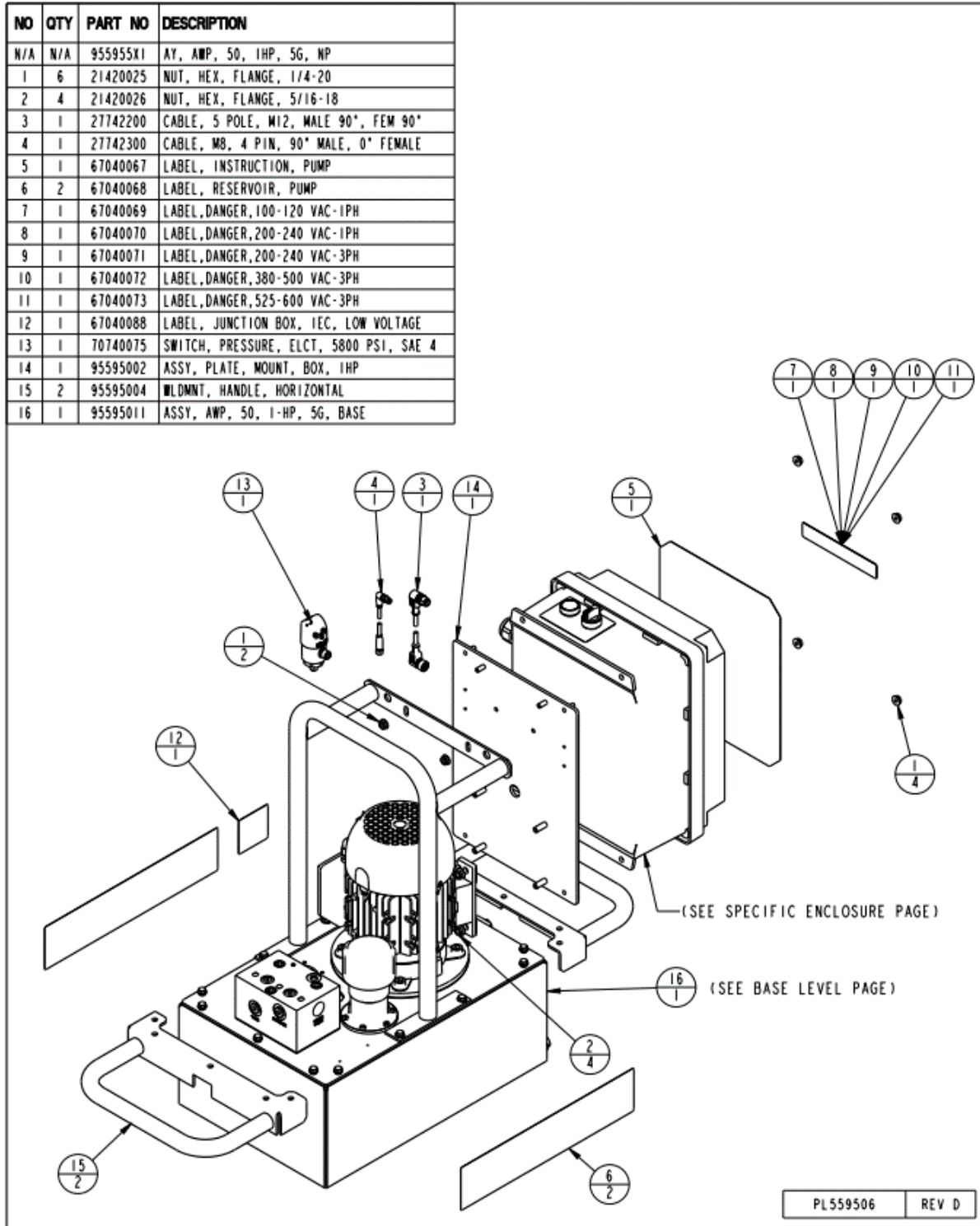

SECTION VI

MAINTENANCE (continued)

12.0 INTERMEDIATE ASSEMBLY, SOLENOID, 1-4 VALVE, PENDANT CONTROL

NO	QTY	PART NO	DESCRIPTION
N/A	N/A	955955X2	AY, AWP, 50, 1HP, 5G, 24V
1	2	21410049	SCREW, CAP, SOCH, 8-32 X 3/8, ALY
2	6	21420025	NUT, HEX, FLANGE, 1/4-20
3	4	21420026	NUT, HEX, FLANGE, 5/16-18
4	1	27742200	CABLE, 5 POLE, M12, MALE 90°, FEM 90°
5	1	27742300	CABLE, M8, 4 PIN, 90° MALE, 0° FEMALE
6	6	28645001	CAP, PORT, PLASTIC, M12
7	1	67040067	LABEL, INSTRUCTION, PUMP
8	2	67040068	LABEL, RESERVOIR, PUMP
9	1	67040069	LABEL, DANGER, 100-120 VAC-1PH
10	1	67040070	LABEL, DANGER, 200-240 VAC-1PH
11	1	67040071	LABEL, DANGER, 200-240 VAC-3PH
12	1	67040072	LABEL, DANGER, 380-500 VAC-3PH
13	1	67040073	LABEL, DANGER, 525-600 VAC-3PH
14	1	67040088	LABEL, JUNCTION BOX, IEC, LOW VOLTAGE
15	1	70740075	SWITCH, PRESSURE, ELCT, 5800 PSI, SAE 4
16	1	95595002	ASSY, PLATE, MOUNT, BOX, 1HP
17	2	95595004	WLDMNT, HANDLE, HORIZONTAL
18	1	95595011	ASSY, AWP, 50, 1-HP, 5G, BASE
19	1	95595502	ASSY, BLOCK, I/O, M12, PENDANT

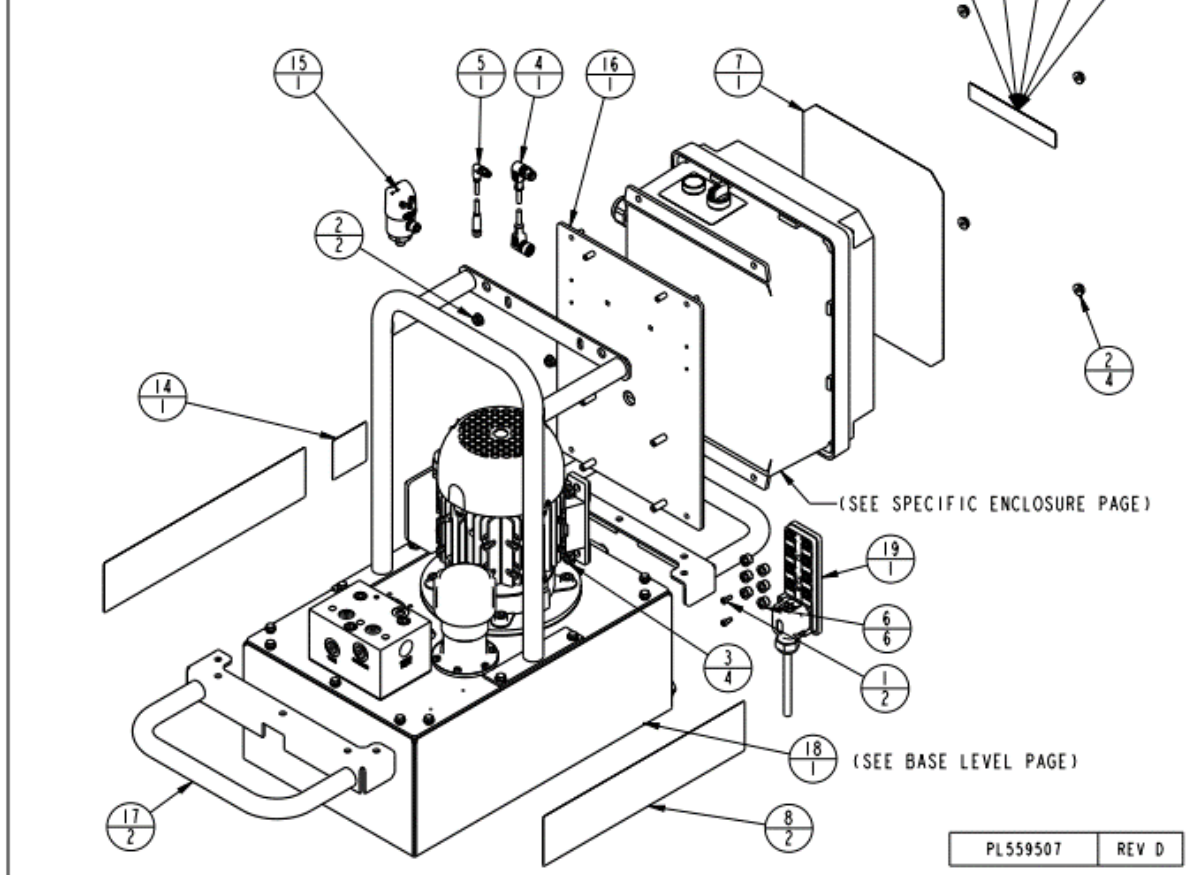

SECTION VI

MAINTENANCE (continued)

13.0 INTERMEDIATE ASSEMBLY, SOLENOID, 5-6 VALVE, PENDANT CONTROL

NO	QTY	PART NO	DESCRIPTION
N/A	N/A	955955X4	AY, AWP, 50, 1HP, 5G, 24V, 5-6 VLV
1	4	21410049	SCREW, CAP, SOCH, 8-32 X 3/8, ALY
2	6	21420025	NUT, HEX, FLANGE, 1/4-20
3	4	21420026	NUT, HEX, FLANGE, 5/16-18
4	1	27742200	CABLE, 5 POLE, M12, MALE 90°, FEM 90°
5	1	27742300	CABLE, M8, 4 PIN, 90° MALE, 0° FEMALE
6	6	28645001	CAP, PORT, PLASTIC, M12
7	1	67040067	LABEL, INSTRUCTION, PUMP
8	2	67040068	LABEL, RESERVOIR, PUMP
9	1	67040069	LABEL, DANGER, 100-120 VAC-1PH
10	1	67040070	LABEL, DANGER, 200-240 VAC-1PH
11	1	67040071	LABEL, DANGER, 200-240 VAC-3PH
12	1	67040072	LABEL, DANGER, 380-500 VAC-3PH
13	1	67040073	LABEL, DANGER, 525-600 VAC-3PH
14	1	67040088	LABEL, JUNCTION BOX, IEC, LOW VOLTAGE
15	1	70740075	SWITCH, PRESSURE, ELCT, 5800 PSI, SAE 4
16	1	95595002	ASSY, PLATE, MOUNT, BOX, 1HP
17	2	95595004	WLDMNT, HANDLE, HORIZONTAL
18	1	95595011	ASSY, AWP, 50, 1-HP, 5G, BASE
19	2	95595502	ASSY, BLOCK, I/O, M12, PENDANT

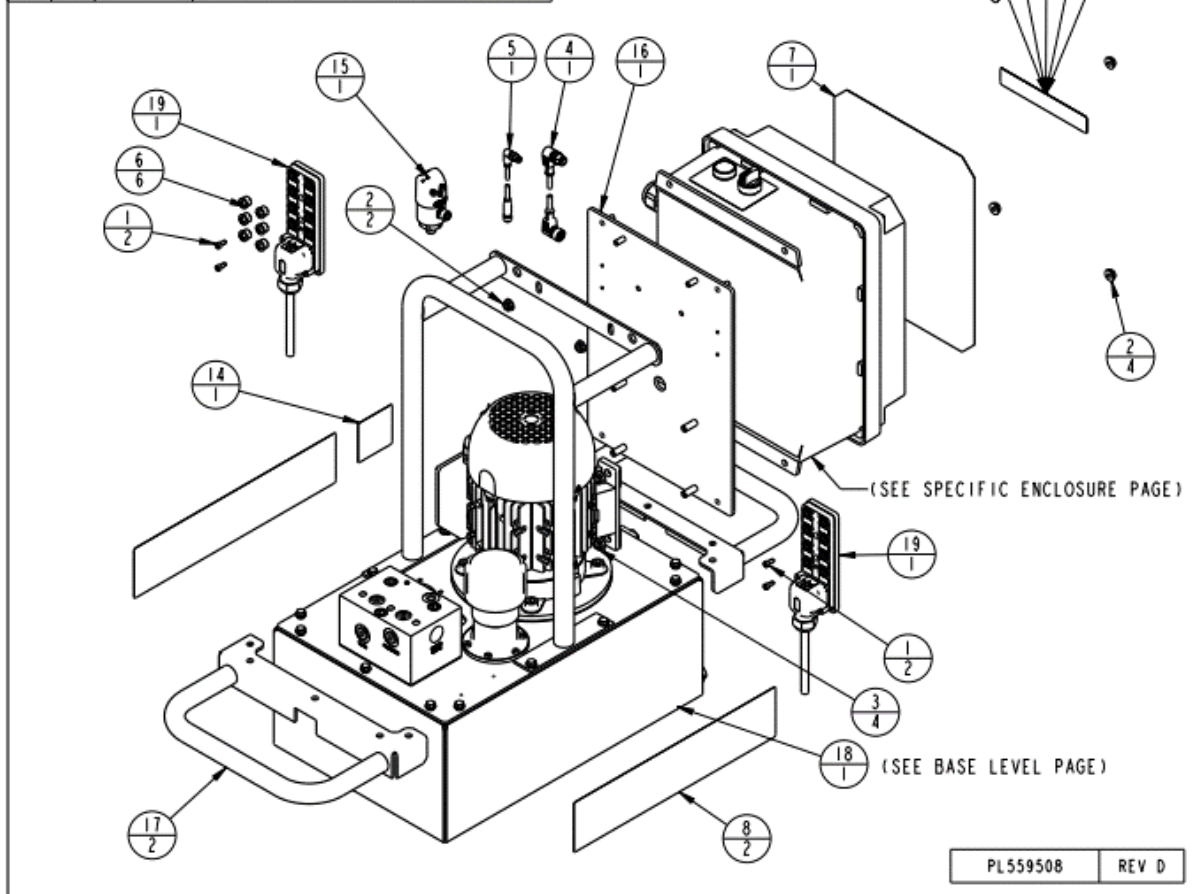

SECTION VI

MAINTENANCE (continued)

14.0 INTERMEDIATE ASSEMBLY SOLENOID, 1-4 VALVE, MACHINE INTERFACE CONTROL

NO	QTY	PART NO	DESCRIPTION
N/A	N/A	955955X3	AY, AWP, 50, 1HP, 5G, 24V, 1-4 VLV, MC
1	6	21420025	NUT, HEX, FLANGE, 1/4-20
2	4	21420026	NUT, HEX, FLANGE, 5/16-18
3	1	27742200	CABLE, 5 POLE, M12, MALE 90°, FEM 90°
4	1	27742300	CABLE, M8, 4 PIN, 90° MALE, 0° FEMALE
5	1	67040067	LABEL, INSTRUCTION, PUMP
6	2	67040068	LABEL, RESERVOIR, PUMP
7	1	67040069	LABEL, DANGER, 100-120 VAC-1PH
8	1	67040070	LABEL, DANGER, 200-240 VAC-1PH
9	1	67040071	LABEL, DANGER, 200-240 VAC-3PH
10	1	67040072	LABEL, DANGER, 380-500 VAC-3PH
11	1	67040073	LABEL, DANGER, 525-600 VAC-3PH
12	1	67040088	LABEL, JUNCTION BOX, IEC, LOW VOLTAGE
13	1	70740075	SWITCH, PRESSURE, ELCT, 5800 PSI, SAE 4
14	1	95595002	ASSY, PLATE, MOUNT, BOX, 1HP
15	2	95595004	WLDMNT, HANDLE, HORIZONTAL
16	1	95595011	ASSY, AWP, 50, 1-HP, 5G, BASE
17	1	95595523	ASSY, AWP, MC, 1-4 VLV

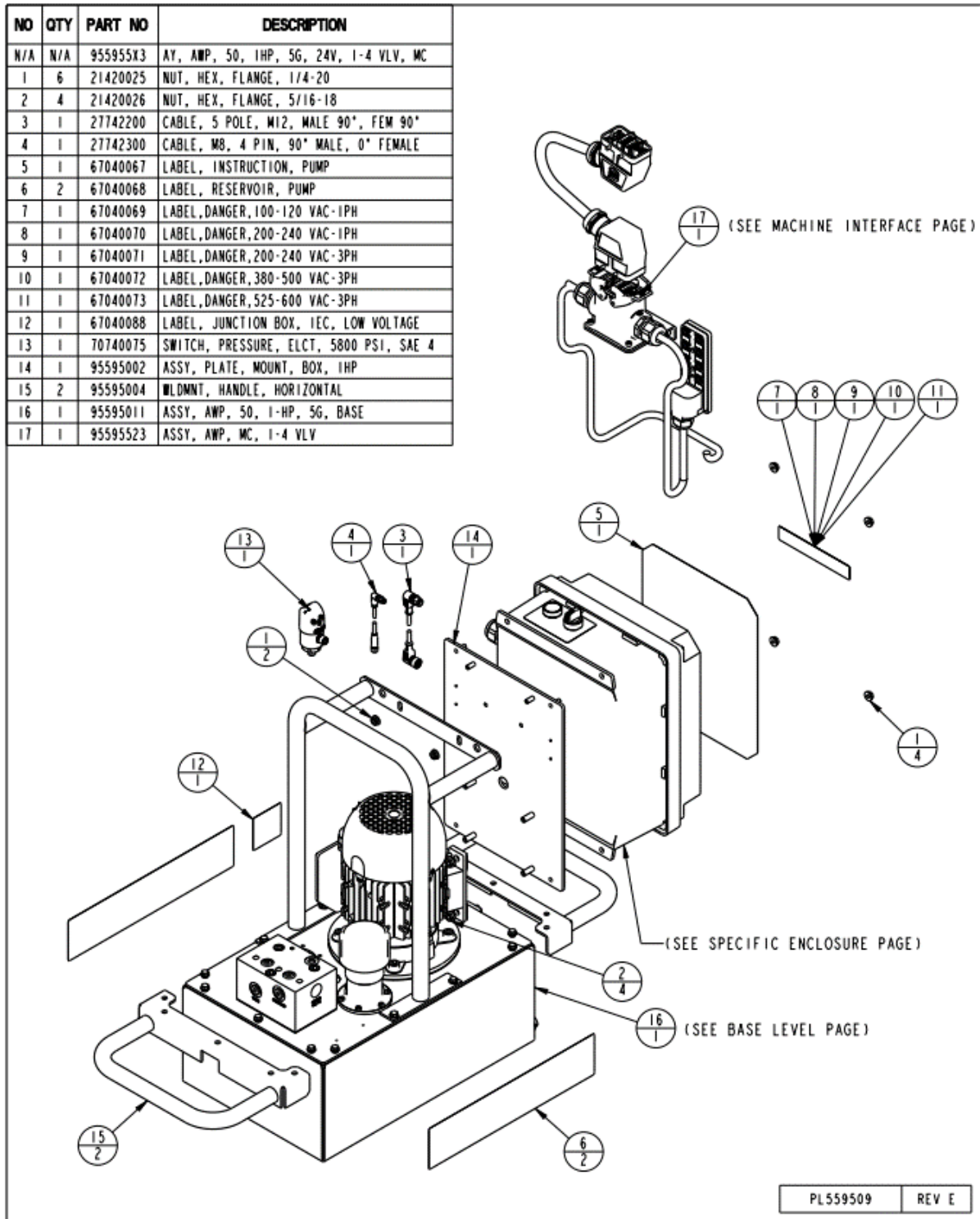

SECTION VI

MAINTENANCE (continued)

15.0 INTERMEDIATE ASSEMBLY, SOLENOID, 5-6 VALVE, MACHINE INTERFACE CONTROL

NO	QTY	PART NO	DESCRIPTION
N/A	N/A	955955X5	AY, AWP, 50, 1HP, 5G, 24V, 5-6 VLV, MC
1	6	21420025	NUT, HEX, FLANGE, 1/4-20
2	4	21420026	NUT, HEX, FLANGE, 5/16-18
3	1	27742200	CABLE, 5 POLE, M12, MALE 90°, FEM 90°
4	1	27742300	CABLE, M8, 4 PIN, 90° MALE, 0° FEMALE
5	1	67040067	LABEL, INSTRUCTION, PUMP
6	2	67040068	LABEL, RESERVOIR, PUMP
7	1	67040069	LABEL, DANGER, 100-120 VAC-1PH
8	1	67040070	LABEL, DANGER, 200-240 VAC-1PH
9	1	67040071	LABEL, DANGER, 200-240 VAC-3PH
10	1	67040072	LABEL, DANGER, 380-500 VAC-3PH
11	1	67040073	LABEL, DANGER, 525-600 VAC-3PH
12	1	67040088	LABEL, JUNCTION BOX, IEC, LOW VOLTAGE
13	1	70740075	SWITCH, PRESSURE, ELCT, 5800 PSI, SAE 4
14	1	95595002	ASSY, PLATE, MOUNT, BOX, 1HP
15	2	95595004	WLDMNT, HANDLE, HORIZONTAL
16	1	95595011	ASSY, AWP, 50, 1-HP, 5G, BASE
17	1	95595602	ASSY, AWP, MC, 5-6 VLV

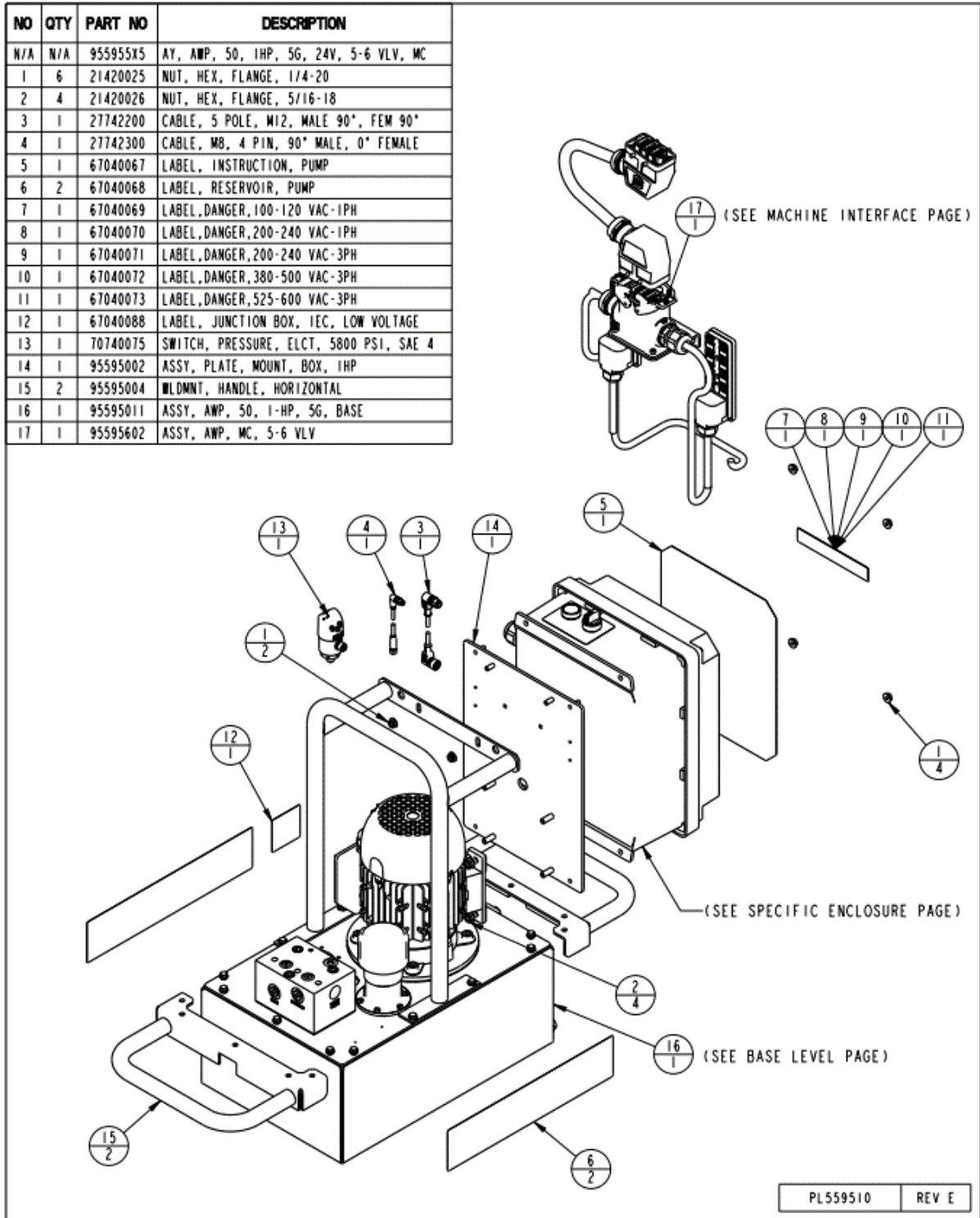

SECTION VI

MAINTENANCE (continued)

16.0 INTERMEDIATE ASSEMBLY, SOLENOID, 1-4 VALVE, MACHINE INTERFACE CONTROL WITH POWER

NO	QTY	PART NO	DESCRIPTION
N/A	N/A	955955X6	AY, AWP, 50, 1HP, 5G, 24V, 1-4 VLV, MC, PWR
1	6	21420025	NUT, HEX, FLANGE, 1/4-20
2	4	21420026	NUT, HEX, FLANGE, 5/16-18
3	1	27742200	CABLE, 5 POLE, M12, MALE 90°, FEM 90°
4	1	27742300	CABLE, M8, 4 PIN, 90° MALE, 0° FEMALE
5	1	67040067	LABEL, INSTRUCTION, PUMP
6	2	67040068	LABEL, RESERVOIR, PUMP
7	1	67040069	LABEL, DANGER, 100-120 VAC-1PH
8	1	67040070	LABEL, DANGER, 200-240 VAC-1PH
9	1	67040071	LABEL, DANGER, 200-240 VAC-3PH
10	1	67040072	LABEL, DANGER, 380-500 VAC-3PH
11	1	67040073	LABEL, DANGER, 525-600 VAC-3PH
12	1	67040088	LABEL, JUNCTION BOX, IEC, LOW VOLTAGE
13	1	70740075	SWITCH, PRESSURE, ELCT, 5800 PSI, SAE 4
14	1	95595002	ASSY, PLATE, MOUNT, BOX, 1HP
15	2	95595004	WLDMNT, HANDLE, HORIZONTAL
16	1	95595011	ASSY, AWP, 50, 1-HP, 5G, BASE
17	1	95595616	ASSY, AWP, MC, 1-4 VLV, PWR

(SEE MACHINE INTERFACE PAGE)

(SEE SPECIFIC ENCLOSURE PAGE)

(SEE BASE LEVEL PAGE)

PL559576 REV E

SECTION VI

MAINTENANCE (continued)

17.0 INTERMEDIATE ASSEMBLY, SOLENOID, 1-4 VALVE, MACHINE INTERFACE CONTROL, OKUMA ETHERNET

NO	QTY	PART NO	DESCRIPTION
N/A	N/A	955955X7	AY, AMP, 50, 1HP, 5G, 24V, 1-4 V, MCE
1	1	21410005	SCREW, CAP, SOCH, 8-32 X 1/4, ALY
2	2	21410063	S.H.C.S. 1/4-20 UNC X .50 LG.
3	6	21420025	NUT, HEX, FLANGE, 1/4-20
4	4	21420026	NUT, HEX, FLANGE, 5/16-18
5	1	27522203	JUMPER, M12, MALE, A-CODE, 4P, 1-4
6	1	27542201	CABLE, M12, 5 POLE, MALE, 5M
7	1	27742200	CABLE, 5 POLE, M12, MALE 90°, FEM 90°
8	1	27742209	CABLE, M12, D-CODED, 4 POLE, MALE, SHLD, 90, 0, 0, 3m
9	1	27742211	CABLE, M12, D-CODED, MALE, 4 P / MALE/RJ45, 5m
10	1	27742213	CABLE, MINI 7/8, 4 POLE, FEMALE, 1.0m
11	1	27742300	CABLE, M8, 4 PIN, 90° MALE, 0° FEMALE
12	1	27844000	STRAP, GROUNDING, 100mm, M4
13	7	28645001	CAP, PORT, PLASTIC, M12
14	2	67040068	LABEL, RESERVOIR, PUMP
15	1	67040071	LABEL, DANGER, 200-240 VAC-3PH
16	1	67040072	LABEL, DANGER, 380-500 VAC-3PH
17	1	67040073	LABEL, DANGER, 525-600 VAC-3PH
18	1	67040088	LABEL, JUNCTION BOX, IEC, LOW VOLTAGE
19	1	67040089	LABEL, JUNCTION BOX, IEC, HIGH VOLTAGE
20	1	67040099	LABEL, ENCLOSURE, MCE
21	1	70740075	SWITCH, PRESSURE, ELCT, 5800 PSI, SAE 4
22	1	85595573	MODULE, ETHERNET IP, DIO 16, 4P
23	1	85595574	PLUG, SCREW, 7/8
24	2	95595004	WLDMNT, HANDLE, HORIZONTAL
25	1	95595011	ASSY, AMP, 50, 1-HP, 5G, BASE
26	1	95595020	ASSY, PLATE, MOUNT, ENCL, 1HP, MCE

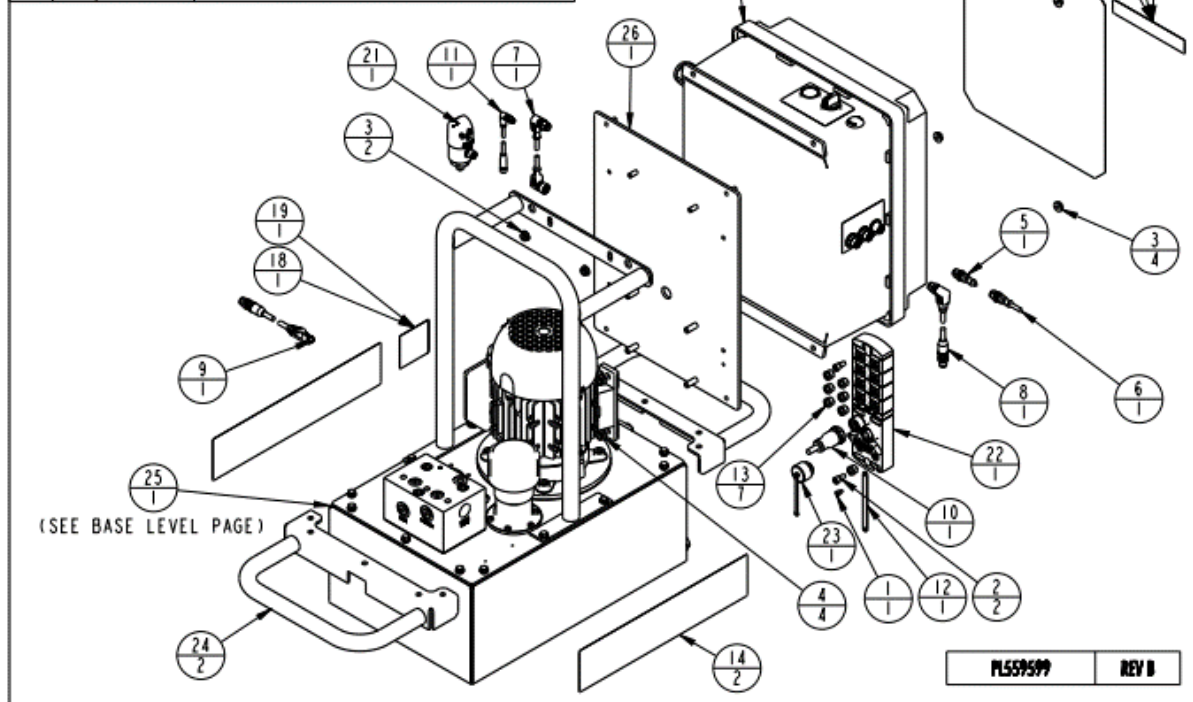

SECTION VI

MAINTENANCE (continued)

18.0 INTERMEDIATE ASSEMBLY, SOLENOID, 5-6 VALVE, MACHINE INTERFACE CONTROL, OKUMA ETHERNET

NO	QTY	PART NO	DESCRIPTION
N/A	N/A	955955X8	AY, AMP, 50, 1HP, 5G, 24V, 5-6 V, MCE
1	2	21410005	SCREW, CAP, SOCH, 8-32 X 1/4, ALY
2	4	21410063	S.H.C.S. 1/4-20 UNC X .50 LG.
3	6	21420025	NUT, HEX, FLANGE, 1/4-20
4	4	21420026	NUT, HEX, FLANGE, 5/16-18
5	1	27522203	JUMPER, M12, MALE, A-CODE, 4P, 1-4
6	1	27542201	CABLE, M12, 5 POLE, MALE, 5M
7	1	27742200	CABLE, 5 POLE, M12, MALE 90°, FEM 90°
8	1	27742209	CABLE, M12, D-CODED, 4 POLE, MALE, SHLD, 90, 0, 0, 3m
9	1	27742210	CABLE, M12, D-CODED, 4P, SHIELD, MALE-MALE, 0.5m
10	1	27742211	CABLE, M12, D-CODED, MALE, 4 P / MALE/RJ45, 5m
11	1	27742213	CABLE, MINI 7/8, 4 POLE, FEMALE, 1.0m
12	1	27742214	CABLE, MINI 7/8, 4 POLE, MALE/FEMALE, .5m
13	1	27742300	CABLE, M8, 4 PIN, 90° MALE, 0° FEMALE
14	2	27844000	STRAP, GROUNDING, 100mm, M4
15	7	28645001	CAP, PORT, PLASTIC, M12
16	2	67040068	LABEL, RESERVOIR, PUMP
17	1	67040071	LABEL, DANGER, 200-240 VAC-3PH
18	1	67040072	LABEL, DANGER, 380-500 VAC-3PH
19	1	67040073	LABEL, DANGER, 525-600 VAC-3PH
20	1	67040088	LABEL, JUNCTION BOX, IEC, LOW VOLTAGE
21	1	67040089	LABEL, JUNCTION BOX, IEC, HIGH VOLTAGE
22	1	67040099	LABEL, ENCLOSURE, MCE
23	1	70740075	SWITCH, PRESSURE, ELCT, 5800 PSI, SAE 4
24	2	85595573	MODULE, ETHERNET IP, DIO 16, 4P
25	1	85595574	PLUG, SCREW, 7/8
26	2	95595004	WLDMNT, HANDLE, HORIZONTAL
27	1	95595011	ASSY, AMP, 50, 1-HP, 5G, BASE
28	1	95595020	ASSY, PLATE, MOUNT, ENCL, 1HP, MCE

(SEE BASE LEVEL PAGE)

(SEE SPECIFIC ENCLOSURE PAGE)

PL5595100 REV B

SECTION VI

MAINTENANCE (continued)

19.0 INTERMEDIATE ASSEMBLY, SOLENOID, 1-4 VALVE, MACHINE INTERFACE CONTROL, HMI ETHERNET

NO	QTY	PART NO	DESCRIPTION
N/A	N/A	955955X7	AV, AWP, 50, 1HP, 5G, 24V, 1-4 V, HMI
1	1	21410005	SCREW, CAP, SOCH, 8-32 X 1/4, ALY
2	2	21410063	S.H.C.S. 1/4-20 UNC X .50 LG.
3	6	21420025	NUT, HEX, FLANGE, 1/4-20
4	4	21420026	NUT, HEX, FLANGE, 5/16-18
5	1	27522203	JUMPER, M12, MALE, A-CODE, 4P, 1-4
6	1	27542201	CABLE, M12, 5 POLE, MALE, 5M
7	1	27742200	CABLE, 5 POLE, M12, MALE 90°, FEM 90°
8	1	27742209	CABLE, M12, D-CODED, 4 POLE, MALE, SHLD, 90, 0, 0, 3m
9	1	27742211	CABLE, M12, D-CODED, MALE, 4 P / MALE/RJ45, 5m
10	1	27742213	CABLE, MINI 7/8, 4 POLE, FEMALE, 1.0m
11	1	27742300	CABLE, M8, 4 PIN, 90° MALE, 0° FEMALE
12	1	27844000	STRAP, GROUNDING, 100mm, M4
13	7	28645001	CAP, PORT, PLASTIC, M12
14	2	67040068	LABEL, RESERVOIR, PUMP
15	1	67040071	LABEL, DANGER, 200-240 VAC-3PH
16	1	67040072	LABEL, DANGER, 380-500 VAC-3PH
17	1	67040073	LABEL, DANGER, 525-600 VAC-3PH
18	1	67040088	LABEL, JUNCTION BOX, IEC, LOW VOLTAGE
19	1	67040089	LABEL, JUNCTION BOX, IEC, HIGH VOLTAGE
20	1	67040099	LABEL, ENCLOSURE, MCE
21	1	70740075	SWITCH, PRESSURE, ELCT, 5800 PSI, SAE 4
22	1	85595573	MODULE, ETHERNET IP, DIO 16, 4P
23	1	85595574	PLUG, SCREW, 7/8
24	2	95595004	WLDMNT, HANDLE, HORIZONTAL
25	1	95595011	ASSY, AWP, 50, 1-HP, 5G, BASE
26	1	95595020	ASSY, PLATE, MOUNT, ENCL, 1HP, MCE
27	1	95595651	ASSY, HMI, ENCLOSURE, CABLE, 7"

SECTION VI

MAINTENANCE (continued)

20.0 INTERMEDIATE ASSEMBLY, SOLENOID, 5-6 VALVE, MACHINE INTERFACE CONTROL, HMI ETHERNET

NO	QTY	PART NO	DESCRIPTION
N/A	N/A	955955X8	AY, AMP, 50, 1HP, 5G, 24V, 5-6 V, HMI
1	2	21410005	SCREW, CAP, SOCH, 8-32 X 1/4, ALY
2	4	21410063	S.H.C.S. 1/4-20 UNC X .50 LG.
3	6	21420025	NUT, HEX, FLANGE, 1/4-20
4	4	21420026	NUT, HEX, FLANGE, 5/16-18
5	1	27522203	JUMPER, M12, MALE, A-CODE, 4P, 1-4
6	1	27542201	CABLE, M12, 5 POLE, MALE, 5M
7	1	27742200	CABLE, 5 POLE, M12, MALE 90°, FEM 90°
8	1	27742209	CABLE, M12, D-CODED, 4 POLE, MALE, SHLD, 90, 0, 0, 3m
9	1	27742210	CABLE, M12, D-CODED, 4P, SHIELD, MALE-MALE, 0, 5m
10	1	27742211	CABLE, M12, D-CODED, MALE, 4 P / MALE/RJ45, 5m
11	1	27742213	CABLE, MINI 7/8, 4 POLE, FEMALE, 1, 0m
12	1	27742214	CABLE, MINI 7/8, 4 POLE, MALE/FEMALE, .5m
13	1	27742300	CABLE, M8, 4 PIN, 90° MALE, 0° FEMALE
14	2	27844000	STRAP, GROUNDING, 100mm, M4
15	7	28645001	CAP, PORT, PLASTIC, M12
16	2	67040068	LABEL, RESERVOIR, PUMP
17	1	67040071	LABEL, DANGER, 200-240 VAC-3PH
18	1	67040072	LABEL, DANGER, 380-500 VAC-3PH
19	1	67040073	LABEL, DANGER, 525-600 VAC-3PH
20	1	67040088	LABEL, JUNCTION BOX, IEC, LOW VOLTAGE
21	1	67040089	LABEL, JUNCTION BOX, IEC, HIGH VOLTAGE
22	1	67040099	LABEL, ENCLOSURE, MCE
23	1	70740075	SWITCH, PRESSURE, ELCT, 5800 PSI, SAE 4
24	2	85595573	MODULE, ETHERNET IP, DIO 16, 4P
25	1	85595574	PLUG, SCREW, 7/8
26	2	95595004	WLDMNT, HANDLE, HORIZONTAL
27	1	95595011	ASSY, AWP, 50, 1-HP, 5G, BASE
28	1	95595020	ASSY, PLATE, MOUNT, ENCL, 1HP, MCE
29	1	95595651	ASSY, HMI, ENCLOSURE, CABLE, 7"

(SEE SPECIFIC ENCLOSURE PAGE)

(SEE BASE LEVEL PAGE)

PL5595712 REV B

SECTION VI

MAINTENANCE (continued)

21.0 HMI, ENCLOSURE, CABLE 7"

NO	QTY	PART NO	DESCRIPTION
N/A	N/A	95595651	ASSY, HMI, ENCLOSURE, CABLE, 7"
1	12	21500063	SCREW, CAP, BTNH, M4 X 8, ALY
2	1	85595077	HMI, PANEL, TOUCH, 7", 24VDC
3	1	85595078	GASKET, HOUSING, HMI, 7"
4	1	85595079	STYLUS, TOUCHSCREEN, RESISTIVE
5	1	95595033	WLDMNT, HOUSING, HMI, 7"
6	1	95595034	WLDMNT, PLATE, MOUNT, HOUSING, HMI, 7"
7	1	95595650	ASSY, CABLE, HYBRID, MALE, RJ45

- NOTE:
 1. CLEAN SURFACES PRIOR TO APPLYING GASKET.
 2. INSTALL HMI USING CLIPS PROVIDED I.A.W. MANUFACTURER INSTRUCTIONS.
 3. CONNECT CABLE POWER AND ETHERNET RJ45 CONNECTOR TO HMI.

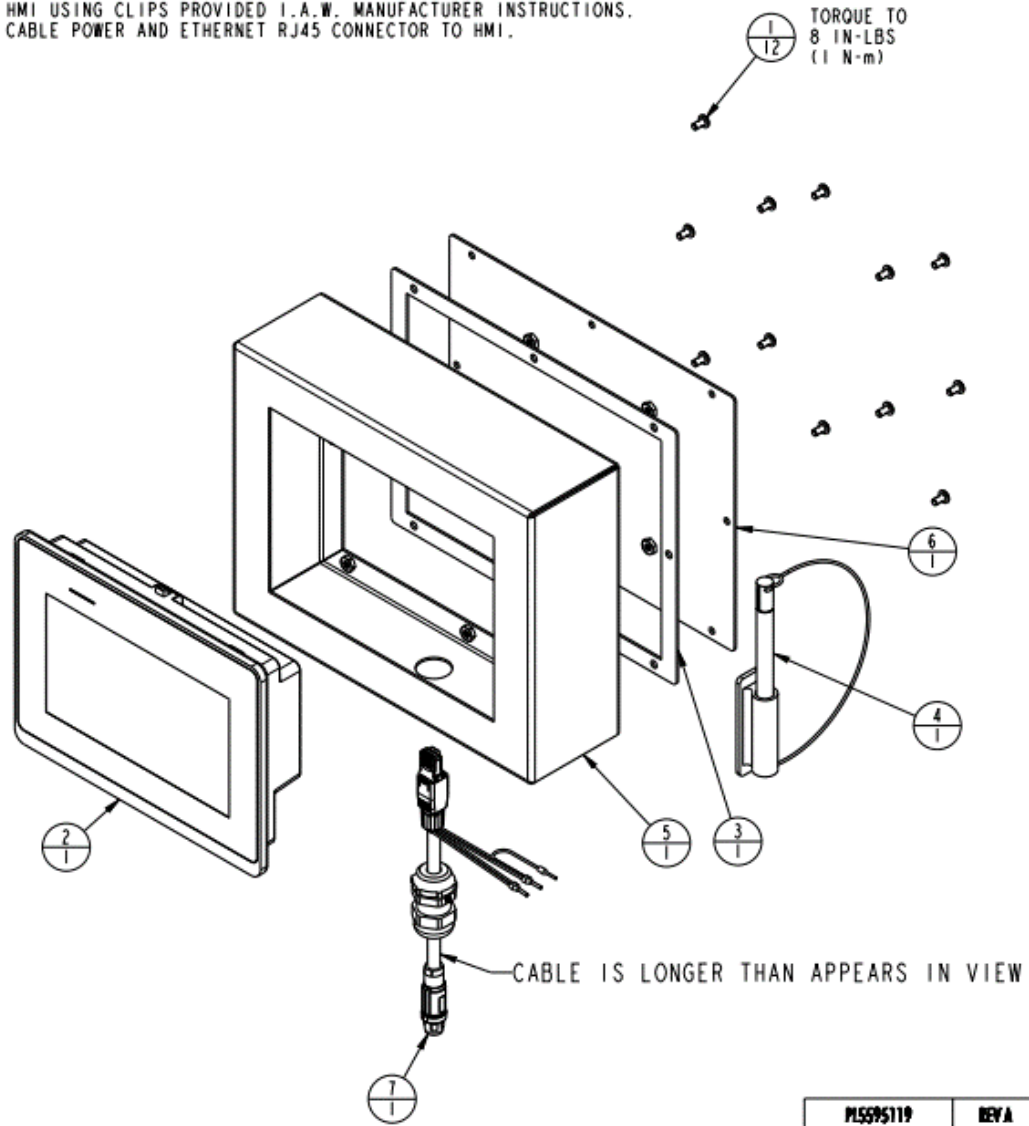

SECTION VI

MAINTENANCE (continued)

22.0 BASE ASSEMBLY, ALL PUMPS

NO	QTY	PART NO	DESCRIPTION
N/A	N/A	95595011	ASSY, AWP, 50, 1HP, 5G, BASE
1	3	21410007	SCREW, CAP, SOCH, 3/8-16 X 3-1/4, ALY
2	4	21410063	S.H.C.S. 1/4-20 UNC X .50 LG.
3	14	21410091	SCREW, HEX, FLNG, 1/4-20 UNC X 5/8
4	4	21500038	SHCS, M10-1.5 X 25, ALY
5	4	21500049	FHSCS, M5 X 0.8 X 12
6	1	28611204	STRAIN RELIEF, CABLE, PG16
7	1	30093388	NIPPLE, 1/2 NPT, 1-1/2
8	2	30601144	PLUG, SOCH, SAE 4
9	1	30603601	PLUG, 3/8-18 NPT, HEX
10	1	30804888	ADAPTER, MALE G1/2 - FEM 1/2 NPT
11	1	31050019	STRAINER, SUMP, DISC, 1/2 NPT
12	1	35000505	TUBE, DRAIN, OPRV
13	1	35000506	TUBE, DRAIN, ULV
14	1	35000507	TUBE, PRESSURE LINE, KKPI
15	4	43000012	CONNECTOR, STR, 8 mm - G1/4 STUD
16	1	67040027	DECAL, ARROW
17	1	67040057	LABEL, ADD OIL
18	1	83109700	PLATE, NUT, MANIFOLD
19	1	85595000	MOTOR, 1-HP, 3-PH, 230/460 VAC
20	1	85595001	GASKET, MOTOR, D80, B5
21	1	85595008	PLATE, DECK, PUMP, 5 GAL, 1-HP
22	1	85595009	GASKET, RESERVIOR, 5 GAL
23	4	85595010	FOOT, RUBBER, 1.00 X .56 X .28
24	1	85595018	GASKET, MANIFOLD, PUMP
25	1	85595025	ASSY, CAP, FILLER, BREATHER, EXT
26	1	85595033	MAGNET, CERAMIC, 1.00 X .25
27	1	95595001	WLDMNT, RESERVIOR, 5 GAL
28	1	95595003	WLDMNT, HANDLE, VERTICAL
29	1	95595005	ASSY, MANIFOLD, PUMP
30	1	95595006	PUMP, COMBO, 80, 400/45
31	1	95595007	INDICATOR, LEVEL, FLUID, 5
32	1	85595060	CAP, FILLER, BREATHER, NEUTRAL

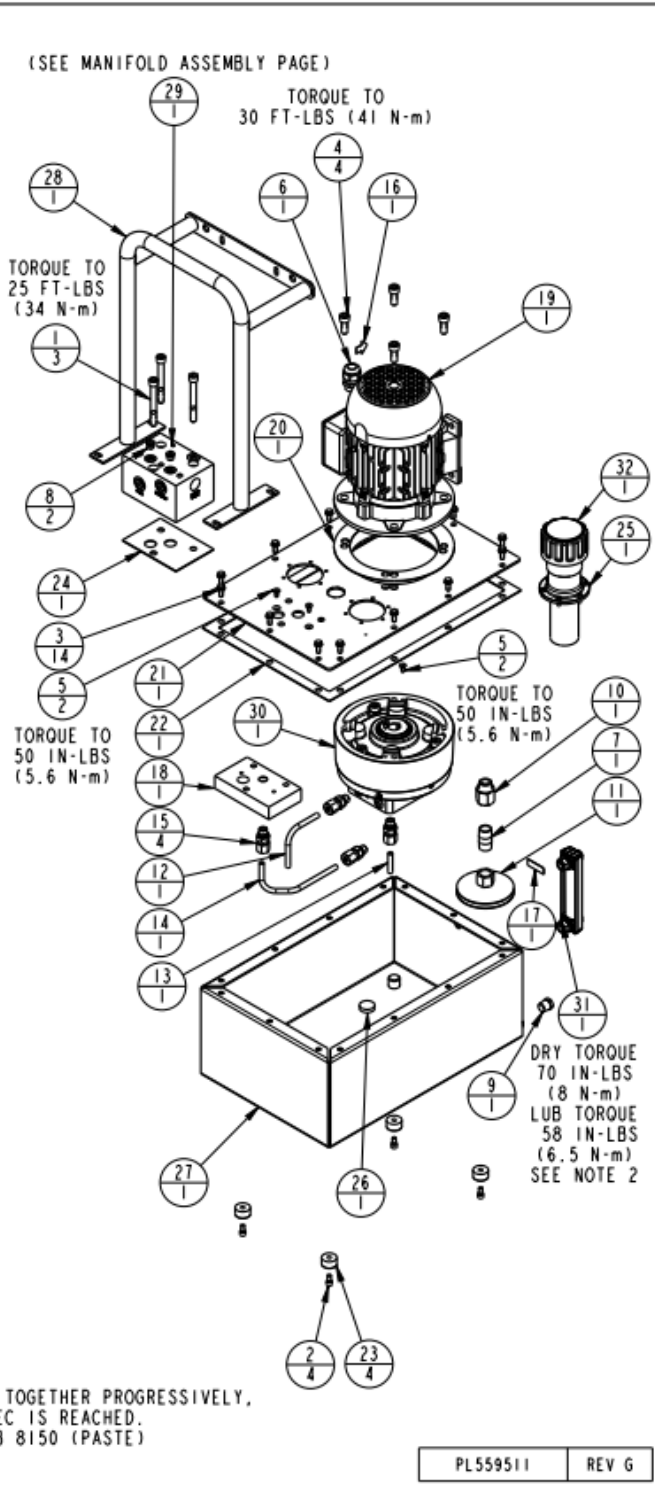

SECTION VI

MAINTENANCE (continued)

23.0 MANIFOLD ASSEMBLY

NO	QTY	PART NO	DESCRIPTION
N/A	N/A	95595005	ASSY, MANIFOLD, PUMP
1	1	21440025	SHSS, FLAT POINT, PELLET
2	1	23313007	SPRING, COMPRESSION
3	1	23355003	SPRING, COMPRESSION
4	1	30601113	PLUG, SOCH, SAE 12, STD
5	2	30601144	PLUG, SOCH, SAE 4
6	2	30601166	PLUG, SOCH, SAE 6
7	1	30603600	PLUG, 1/4-18 NPT
8	1	31091005	FILTER, CUP, BRONZE, SINTERED, GR 83
9	2	39002009	O-RING, (-012)
10	2	39054010	BU RING, (-012)
11	1	70343760	VALVE, CHECK, SAE 4, 30 PSI
12	1	85534272	SEAT, RELIEF, OVERPRESSURE, PUMP
13	1	85534273	NEEDLE, RELIEF, OVERPRESSURE, PUMP
14	1	85534275	ADAPTER, MANIFOLD, PUMP
15	1	85595019	GASKET, FILTER, STEPPED, BONDED

TORQUE TO
130 FT-LBS (14.7 N-m)

TORQUE TO
100 IN-LBS (11.3 N-m)

TORQUE TO
25 IN-LBS (2.8 N-m)
USING TOOL 65-6000-00

TORQUE TO
7 FT-LBS (0.8 N-m)

TORQUE TO
16 FT-LBS (1.8 N-m)

INSTALL PIPE PLUG IN
BOTTOM OF PUMP MANIFOLD
APPLY PIPE THREAD SEALANT

APPLY LUBRICANT TO ALL SEALS PRIOR TO INSTALLATION.
DO NOT USE SILICONE LUBRICANTS.

PL559512
REV E

SECTION VI

MAINTENANCE (continued)

24.0 RETURN LINE FILTER, VISUAL CLOG INDICATOR

NO	QTY	PART NO	DESCRIPTION
N/A	N/A	95595009	ASSY, FILTER, VISUAL CLOG INDICATOR
1	6	21500031	SHCS, M5 x 0.8 x 14, ALY
2	4	21500050	SHCS, M4-0.7 X 14, ALY
3	1	30000166	CONNECTOR, 3/8 FLRL TB - SAE 6
4	1	30160368	ELBOW, 90, 3/8 FLRL TB - 1/2 NPTF
5	1	35000600	TUBE, RETURN LINE
6	1	35300100	HOSE, 1.00 X 4.00
7	1	35300101	CLAMP, HOSE, 3/4 - 1 3/4
8	1	67040101	TAG, INDICATOR, CLOG, FILTER
9	1	85595020	MOUNT, FILTER, IN-LINE
10	1	85595021	INDICATOR, VISUAL, CLOG, FILTER
11	1	85595023	GASKET, FILLER, BREATHER
12	1	95595008	FILTER, FILLER, IN-LINE
13	1	31050018	FILTER, CARTRIDGE, 10 MICRON, REPLACEMENT

TORQUE TO 10 IN-LBS (1.1 N-m)

TORQUE TO 20 IN-LBS (2.2 N-m)

TORQUE TO 35 IN-LBS (4 N-m)

APPLY PIPE THREAD SEALANT TO ALL PIPE THREADS

PL559513 REV C

SECTION VI

MAINTENANCE (continued)

25.0 RETURN LINE FILTER, ELECTRONIC CLOG INDICATOR

NO	QTY	PART NO	DESCRIPTION
N/A	N/A	95595010	ASSY, FILTER, ELECT CLOG INDICATOR
1	6	21500031	SHCS, M5 x 0.8 x 14, ALY
2	4	21500050	SHCS, M4-0.7 X 14, ALY
3	1	30000166	CONNECTOR, 3/8 FLRL TB - SAE 6
4	1	30160368	ELBOW, 90, 3/8 FLRL TB - 1/2 NPTF
5	1	35000600	TUBE, RETURN LINE
6	1	35300100	HOSE, 1.00 X 4.00
7	1	35300101	CLAMP, HOSE, 3/4 - 1 3/4
8	1	85595020	MOUNT, FILTER, IN-LINE
9	1	85595022	INDICATOR, ELECTRONIC, CLOG, FILTER
10	1	85595023	GASKET, FILLER, BREATHER
11	1	95595008	FILTER, FILLER, IN-LINE
12	1	95595550	AY, CABLE, FILTER, CLOG, SW
14	1	31050018	FILTER, CARTRIDGE, 10 MICRON, REPLACEMENT

TORQUE TO 10 IN-LBS (1.1 N-m)

TORQUE TO 20 IN-LBS (2.2 N-m)

TORQUE TO 35 IN-LBS (4 N-m)

APPLY PIPE THREAD SEALANT TO ALL PIPE THREADS

PL559514 REV C

SECTION VI

MAINTENANCE (continued)

26.0 COVER ASSEMBLY, NO RETURN LINE FILTER

NO	QTY	PART NO	DESCRIPTION
N/A	N/A	95595013	ASSY, COVER, NO RETURN LINE FILTER
1	6	21500031	SHCS, M5 x 0,8 x 14, ALY
2	1	30093347	NIPPLE, PIPE, 1/4 NPT X 7, BRASS
3	1	85595023	GASKET, FILLER, BREATHER
4	1	85595024	PLATE, COVER, FILTER, FILLER

INSTALL LONG NIPPLE
IN BOTTOM OF PUMP MANIFOLD
NO THREAD SEALANT REQUIRED

TORQUE TO
50 IN-LBS
(5.6 N-m)

PL559515 REV A

SECTION VI

MAINTENANCE (continued)

27.0 WATER ABSORBING FILTER, 10 µm

NO	QTY	PART NO	DESCRIPTION
N/A	N/A	62559507	ASSY, FILTER, WATER ABSORBING, 10 µm
N/A	N/A	62559508	ASSY, FILTER, WATER ABSORBING, 10 µm, CART
1	1	30000166	CONNECTOR, 3/8 FLRL TB - SAE 6
2	1	30093389	NIPPLE, BRASS, 1/2 NPT X 3
3	1	30093390	NIPPLE, BRASS, 1/2 NPT X 6
4	1	30160368	ELBOW, 90, 3/8 FLRL TB - 1/2 NPTF
5	2	30884388	ADAPTER, BRASS, 3/4 NPT M X 1/2 NPT F
6	1	31050026	FILTER, SPIN-ON, 10 µm, WATER ABS
7	1	31148100	HEAD, FILTER, SPIN ON, 25 PSI BYPASS
8	1	35000601	TUBE, RETURN LINE, FILTER, WAF
9	1	35000602	TUBE, RETURN LINE, FILTER, WAF, CART
10	1	72021125	INDICATOR, VISUAL, FILTER, 25 PSI BYPASS

NOTES:
1. APPLY PIPE SEALANT TO THREADS.

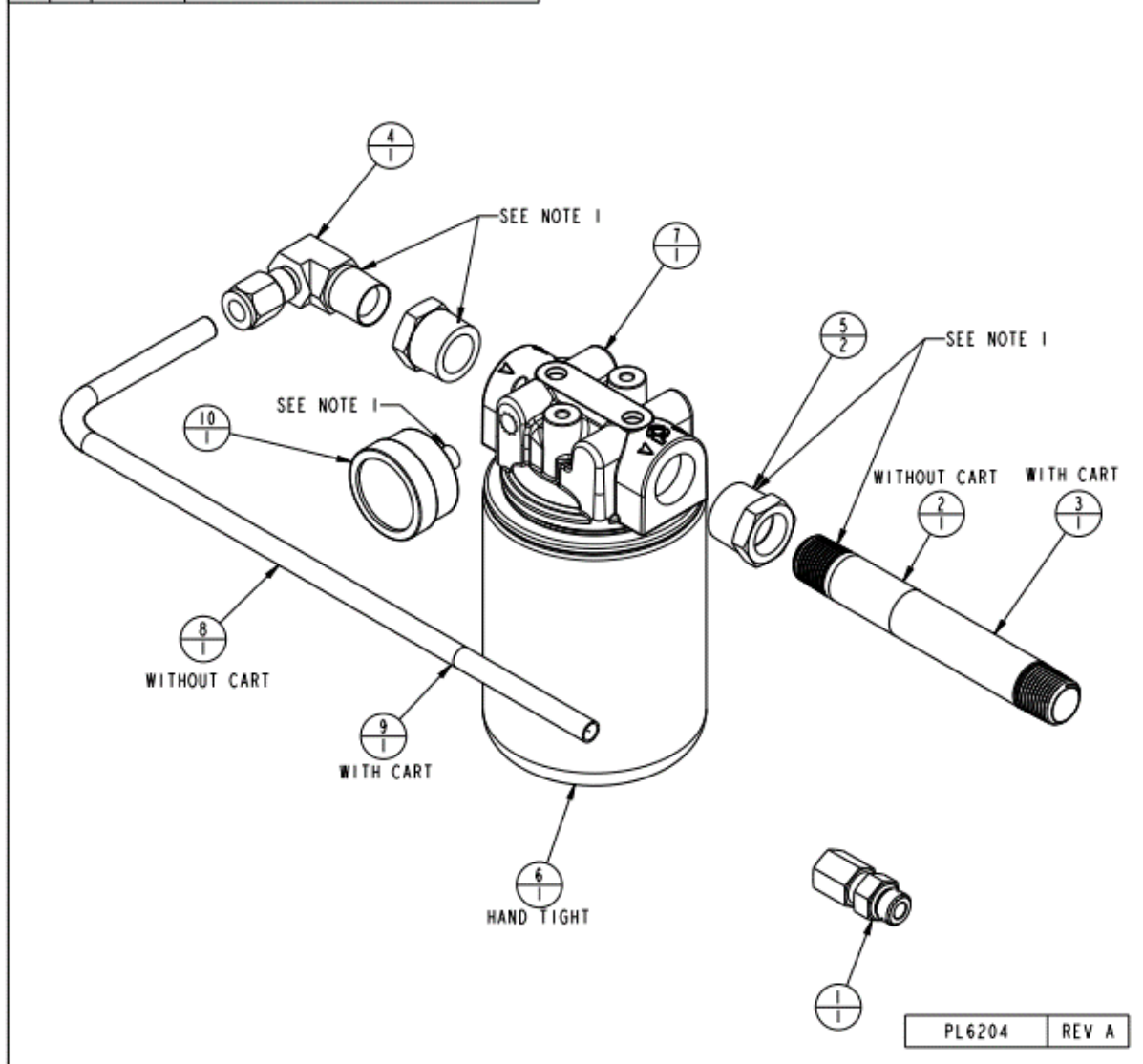

SECTION VI

MAINTENANCE (continued)

28.0 PENDANT, 3/2 VALVE, NORMALLY OPEN

NO	QTY	PART NO	DESCRIPTION
N/A	N/A	95595537	ASSY, PENDANT, 3/2 VALVE, NO
1	1	21410062	FLAT HEAD CAP SCREW, 10-32 x 1/2
2	4	21410093	SCREW, TORX, 6-19 x .75
3	1	21410094	SCREW, RND HEAD, 4-40 x .19
4	2	21420028	INSERT, THREADED, 10-32 x 3/8
5	1	27542200	CABLE, M12, 5 POLE, MALE, 2M
6	1	28112100	TERMINAL, RING, INSUL, 18-22 GA, #4
7	1	28611201	RELIEF, STRAIN, CORD, FLEX, 3/8 NPT
8	1	28611202	NUT, LOCK, GLAND, 3/8 NPT
9	1	28611203	RING, GROUNDING, 3/8 NPT
10	1	29121101	SWITCH, ROCKER, 2 POSITION
11	1	67040079	DECAL, SWITCH, PENDANT
12	1	85595027	BOX, SWITCH, PENDANT, ROCKER
13	1	85595028	COVER, SWITCH, PENDANT
14	1	85595029	GASKET, SWITCH, PENDANT
15	1	85595034	MAGNET, CERAMIC, 1.57 x .31
16	1	85595035	RING, TIE-DOWN, 1/4

PIN 4, BLACK WIRE
PIN 1, BROWN WIRE

TIGHTEN UNTIL SNUG
DO NOT OVER TIGHTEN

TIGHTEN UNTIL SNUG
DO NOT OVER TIGHTEN

NOTE:

1. STRIP APPROX. 4" OF INSULATION FROM CABLE AND 1/4" FROM INDIVIDUAL WIRES BEING USED.
2. SOLDER WIRES AS SHOWN TO SWITCH TERMINALS.
3. CRIMP GREEN/YELLOW WIRE TO RING TERMINAL AND SCREW TO GROUND RING.
4. CRIMP EACH UNUSED WIRE WITH INSULATED CAP.

PL559533	REV A
----------	-------

SECTION VI

MAINTENANCE (continued)

29.0 PENDANT, 3/2 VALVE, NORMALLY CLOSED

NO	QTY	PART NO	DESCRIPTION
N/A	N/A	95595538	ASSY, PENDANT, 3/2 VALVE, NC
1	1	21410062	FLAT HEAD CAP SCREW, 10-32 x 1/2
2	4	21410093	SCREW, TORX, 6-19 X .75
3	1	21410094	SCREW, RND HEAD, 4-40 X .19
4	2	21420028	INSERT, THREADED, 10-32 x 3/8
5	1	27542200	CABLE, M12, 5 POLE, MALE, 2M
6	1	28112100	TERMINAL, RING, INSUL, 18-22 GA, #4
7	1	28611201	RELIEF, STRAIN, CORD, FLEX, 3/8 NPT
8	1	28611202	NUT, LOCK, GLAND, 3/8 NPT
9	1	28611203	RING, GROUNDING, 3/8 NPT
10	1	29121101	SWITCH, ROCKER, 2 POSITION
11	1	67040079	DECAL, SWITCH, PENDANT
12	1	85595027	BOX, SWITCH, PENDANT, ROCKER
13	1	85595028	COVER, SWITCH, PENDANT
14	1	85595029	GASKET, SWITCH, PENDANT
15	1	85595034	MAGNET, CERAMIC, 1.57 X .31
16	1	85595035	RING, TIE-DOWN, 1/4

PIN 4, BLACK WIRE
PIN 1, BROWN WIRE

TIGHTEN UNTIL SNUG
DO NOT OVER TIGHTEN

TIGHTEN UNTIL SNUG
DO NOT OVER TIGHTEN

NOTE:

1. STRIP APPROX. 4" OF INSULATION FROM CABLE AND 1/4" FROM INDIVIDUAL WIRES BEING USED.
2. SOLDER WIRES AS SHOWN TO SWITCH TERMINALS.
3. CRIMP GREEN/YELLOW WIRE TO RING TERMINAL AND SCREW TO GROUND RING.
4. CRIMP EACH UNUSED WIRE WITH INSULATED CAP.

PL559534 REV A

SECTION VI

MAINTENANCE (continued)

30.0 PENDANT, 3/2 VALVE, NORMALLY CLOSED, MOMENTARY

NO	QTY	PART NO	DESCRIPTION
N/A	N/A	95595539	ASSY, PENDANT, 3/2 VALVE, NC, MOM
1	1	21410062	FLAT HEAD CAP SCREW, 10-32 x 1/2
2	4	21410093	SCREW, TORX, 6-19 X .75
3	1	21410094	SCREW, RND HEAD, 4-40 X .19
4	2	21420028	INSERT, THREADED, 10-32 x 3/8
5	1	27542200	CABLE, M12, 5 POLE, MALE, 2M
6	1	28112100	TERMINAL, RING, INSUL, 18-22 GA, #4
7	1	28611201	RELIEF, STRAIN, CORD, FLEX, 3/8 NPT
8	1	28611202	NUT, LOCK, GLAND, 3/8 NPT
9	1	28611203	RING, GROUNDING, 3/8 NPT
10	1	29122101	SWITCH, ROCKER, 2 POSITION, MOM
11	1	67040079	DECAL, SWITCH, PENDANT
12	1	85595027	BOX, SWITCH, PENDANT, ROCKER
13	1	85595028	COVER, SWITCH, PENDANT
14	1	85595029	GASKET, SWITCH, PENDANT
15	1	85595034	MAGNET, CERAMIC, 1.57 X .31
16	1	85595035	RING, TIE-DOWN, 1/4

PIN 4, BLACK WIRE
PIN 1, BROWN WIRE

TIGHTEN UNTIL SNUG
DO NOT OVER TIGHTEN

TIGHTEN UNTIL SNUG
DO NOT OVER TIGHTEN

NOTE:

1. STRIP APPROX. 4" OF INSULATION FROM CABLE AND 1/4" FROM INDIVIDUAL WIRES BEING USED.
2. SOLDER WIRES AS SHOWN TO SWITCH TERMINALS.
3. CRIMP GREEN/YELLOW WIRE TO RING TERMINAL AND SCREW TO GROUND RING.
4. CRIMP EACH UNUSED WIRE WITH INSULATED CAP.

PL559535 REV A

SECTION VI

MAINTENANCE (continued)

31.0 PENDANT, 4/3 VALVE, CLOSED CENTER OR PRESSURE BLOCKED CENTER

NO	QTY	PART NO	DESCRIPTION
N/A	N/A	95595540	ASSY, PENDANT, 4/3 VALVE, CC OR PBC
1	1	21410062	FLAT HEAD CAP SCREW, 10-32 x 1/2
2	4	21410093	SCREW, TORX, 6-19 x .75
3	1	21410094	SCREW, RND HEAD, 4-40 x .19
4	2	21420028	INSERT, THREADED, 10-32 x 3/8
5	1	27542200	CABLE, M12, 5 POLE, MALE, 2M
6	1	28112100	TERMINAL, RING, INSUL, 18-22 GA, #4
7	1	28611201	RELIEF, STRAIN, CORD, FLEX, 3/8 NPT
8	1	28611202	NUT, LOCK, GLAND, 3/8 NPT
9	1	28611203	RING, GROUNDING, 3/8 NPT
10	1	29123101	SWITCH, ROCKER, 3 POSITION
11	1	67040079	DECAL, SWITCH, PENDANT
12	1	85595027	BOX, SWITCH, PENDANT, ROCKER
13	1	85595028	COVER, SWITCH, PENDANT
14	1	85595029	GASKET, SWITCH, PENDANT
15	1	85595034	MAGNET, CERAMIC, 1.57 X .31
16	1	85595035	RING, TIE-DOWN, 1/4

PIN 4, BLACK WIRE
PIN 1, BROWN WIRE
PIN 2, WHITE WIRE

TIGHTEN UNTIL SNUG
DO NOT OVER TIGHTEN

TIGHTEN UNTIL SNUG
DO NOT OVER TIGHTEN

NOTE:
 1. STRIP APPROX. 4" OF INSULATION FROM CABLE AND 1/4" FROM INDIVIDUAL WIRES BEING USED.
 2. SOLDER WIRES AS SHOWN TO SWITCH TERMINALS.
 3. CRIMP GREEN/YELLOW WIRE TO RING TERMINAL AND SCREW TO GROUND RING.
 4. CRIMP EACH UNUSED WIRE WITH INSULATED CAP.

PL559536
REV A

SECTION VI

MAINTENANCE (continued)

32.0 CONTROL, 2-HAND, NO-TIE-DOWN, 24VDC I/O

NO	QTY	PART NO	DESCRIPTION
N/A	N/A	95595015	ASSY, CONTROL, 2-HAND, NTD, 24VDC I/O
1	1	27742203	CABLE, M12 MALE, M12 FEMALE, 5 POLE, 5M
2	1	67040018	LABEL, WORKHOLDING EQUIPMENT
3	1	95595014	CONTROL, 2-HAND, NTD, 24VDC I/O
4	1	1S5503	INSTR SHEET, CONTROL, 2-HAND, NTD

PL559577	REV A
----------	-------

SECTION VI

MAINTENANCE (continued)

33.0D03 STACK BLOCK

NO	QTY	PART NO	DESCRIPTION
N/A	N/A	95595401	KIT, VLV. D03 STACK BLOCK
1	2	30601166	PLUG, SOCH, SAE 6
2	2	39000061	O-RING, (-016)
3	2	70040710	ASSY, FILTER, 25 MICRON, SAE 6- SAE 6
4	1	83107804	BLOCK, STACK, D03, TALL
5	1	93198901	ASSY, PLATE, BLANKING, D03
6	4	21411029	SOCH, 10-24 X .875, ALY

P A B T

TORQUE TO
80 IN-LBS
(9 N-M)

(SCREWS & O-RINGS INCLUDED WITH PLATE)

PL559516	REV B
----------	-------

SECTION VI

MAINTENANCE (continued)

34.0 VALVE ASSEMBLY, MANUAL, 3/2 ,SINGLE

NO	QTY	PART NO	DESCRIPTION
N/A	N/A	95595412	KIT, VLV, 3/2, MNL, SGL
1	4	21411027	SOCH, 10-24 X 1-1/4, ALY
2	2	30601166	PLUG, SOCH, SAE 6
3	2	39000061	O-RING, (-016)
4	1	70040710	ASSY, FILTER, 25 MICRON, SAE 6- SAE 6
5	1	71142204	ASSY, VALVE, MANUAL, D03, 3/2
6	1	83107804	BLOCK, STACK, D03, TALL
7	1	85600902	HANDLE, VALVE, LONG

(SCREWS INCLUDED WITH VALVE)

TORQUE TO
80 IN-LBS
(9 N-M)

(OPTIONAL LONG HANDLE INCLUDED WITH VALVE)

PL559517 REV C

SECTION VI

MAINTENANCE (continued)

35.0 VALVE ASSEMBLY, MANUAL, 3/2, MULTIPLE

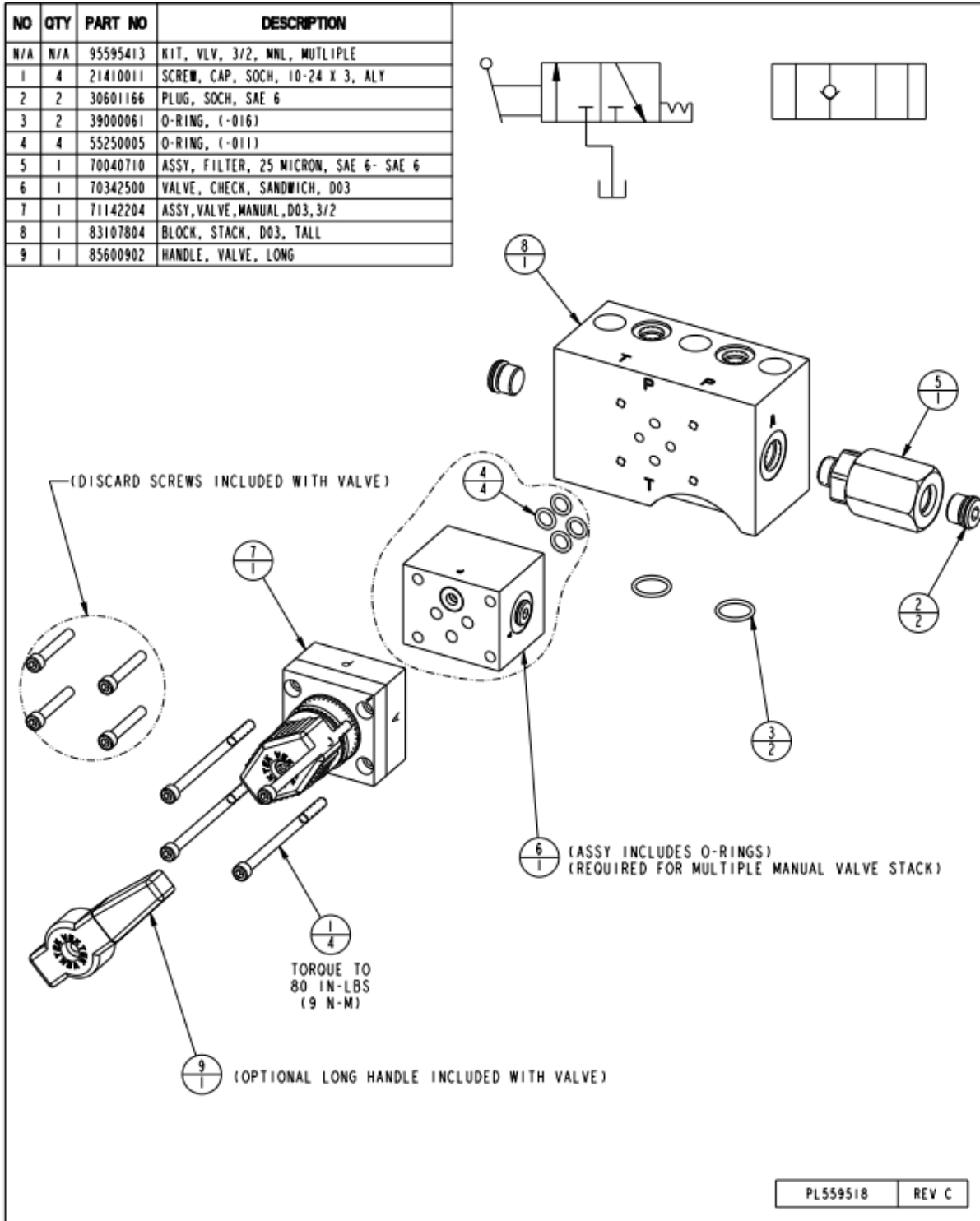

SECTION VI

MAINTENANCE (continued)

36.0 VALVE ASSEMBLY, MANUAL, 4/3, CLOSED CENTER, SINGLE

NO	QTY	PART NO	DESCRIPTION
N/A	N/A	95595416	KIT, VLV, 4/3, MNL, CC, SGL
1	4	21411027	SOCH, 10-24 X 1-1/4, ALY
2	2	30601166	PLUG, SOCH, SAE 6
3	2	39000061	O-RING, (-016)
4	2	70040710	ASSY, FILTER, 25 MICRON, SAE 6- SAE 6
5	1	71147402	ASSY, VALVE, MANUAL, D03, 4/3, PBC
6	1	83107804	BLOCK, STACK, D03, TALL
7	1	85600902	HANDLE, VALVE, LONG

(SCREWS INCLUDED WITH VALVE)

TORQUE TO
80 IN-LBS
(9 N-M)

(OPTIONAL LONG HANDLE INCLUDED WITH VALVE)

PL559519 REV C

SECTION VI

MAINTENANCE (continued)

37.0 VALVE ASSEMBLY, MANUAL, 4/3, PRESSURE BLOCKED CENTER, SINGLE

NO	QTY	PART NO	DESCRIPTION
N/A	N/A	95595417	KIT, VLV, 4/3, MNL, PBC, SGL
1	4	21411027	SOCH, 10-24 X 1-1/4, ALY
2	2	30601166	PLUG, SOCH, SAE 6
3	2	39000061	O-RING, (-016)
4	2	70040710	ASSY, FILTER, 25 MICRON, SAE 6- SAE 6
5	1	71147402	ASSY, VALVE, MANUAL, D03, 4/3, PBC
6	1	83107804	BLOCK, STACK, D03, TALL
7	1	85600902	HANDLE, VALVE, LONG

(SCREWS INCLUDED WITH VALVE)

TORQUE TO
80 IN-LBS
(9 N·M)

(OPTIONAL LONG HANDLE INCLUDED WITH VALVE)

PL559520 REV C

SECTION VI

MAINTENANCE (continued)

38.0 VALVE ASSEMBLY, MANUAL, 4/3, CLOSED CENTER, MULTIPLE

NO	QTY	PART NO	DESCRIPTION
N/A	N/A	95595418	KIT, VLV, 4/3, MNL, CC, MULTIPLE
1	4	21410011	SCREW, CAP, SOCH, 10-24 X 3, ALY
2	2	30601166	PLUG, SOCH, SAE 6
3	2	39000061	O-RING, (-016)
4	4	55250005	O-RING, (-011)
5	2	70040710	ASSY, FILTER, 25 MICRON, SAE 6- SAE 6
6	1	70342500	VALVE, CHECK, SANDWICH, D03
7	1	71147202	ASSY, VALVE, MANUAL, D03, 4/3, CC
8	1	83107804	BLOCK, STACK, D03, TALL
9	1	85600902	HANDLE, VALVE, LONG

(DISCARD SCREWS INCLUDED WITH VALVE)

TORQUE TO
80 IN-LBS
(9 N-M)

(OPTIONAL LONG HANDLE INCLUDED WITH VALVE)

(ASSY INCLUDES O-RINGS)
(REQUIRED FOR MULTIPLE MANUAL VALVE STACK)

PL559521 REV C

SECTION VI

MAINTENANCE (continued)

39.0 VALVE ASSEMBLY, MANUAL, 4/3, PRESSURE BLOCKED CENTER, MULTIPLE

NO	QTY	PART NO	DESCRIPTION
N/A	N/A	95595419	KIT, VLV, 4/3, MNL, PBC, MULTIPLE
1	4	21410011	SCREW, CAP, SOCH, 10-24 X 3, ALY
2	2	30601166	PLUG, SOCH, SAE 6
3	2	39000061	O-RING, (-016)
4	4	55250005	O-RING, (-011)
5	2	70040710	ASSY, FILTER, 25 MICRON, SAE 6- SAE 6
6	1	70342500	VALVE, CHECK, SANDWICH, D03
7	1	71147402	ASSY, VALVE, MANUAL, D03, 4/3, PBC
8	1	83107804	BLOCK, STACK, D03, TALL
9	1	85600902	HANDLE, VALVE, LONG

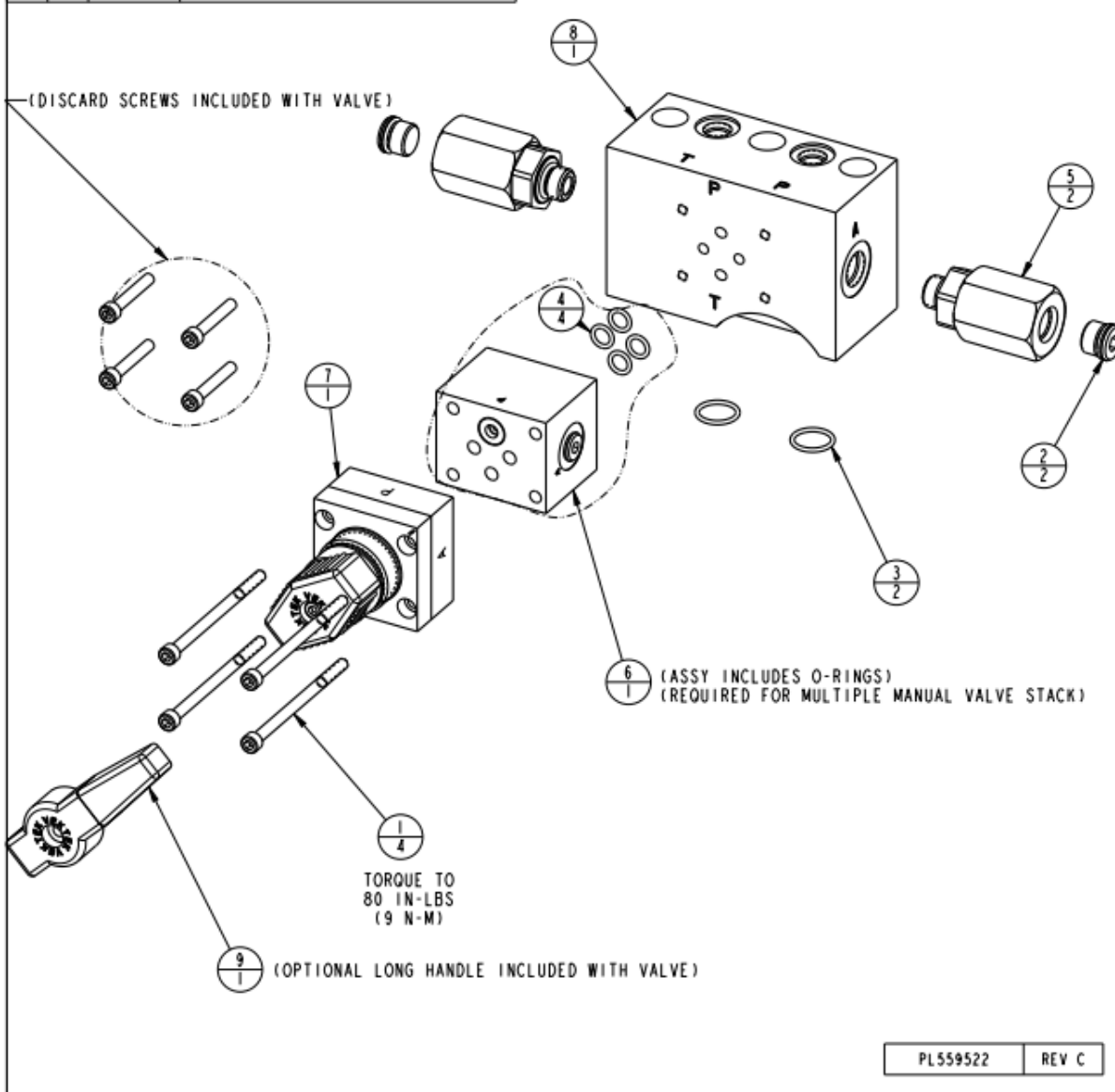
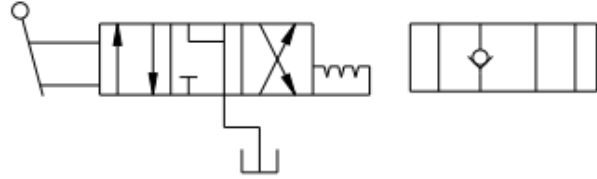

PL559522 REV C

SECTION VI

MAINTENANCE (continued)

40.0 VALVE ASSEMBLY, SOLENOID, 24V, 3/2, NORMALLY OPEN

NO	QTY	PART NO	DESCRIPTION
N/A	N/A	95595423	KIT, VLV, 3/2, 24VDC, NO
1	1	27742201	CABLE, M12 MALE, M12 FEM, 5 POLE, 0.6m
2	1	27742202	ADAPTER, DIN FORM A, M12 MALE
3	2	30601166	PLUG, SOCH, SAE 6
4	2	39000061	O-RING, (-016)
5	1	70040710	ASSY, FILTER, 25 MICRON, SAE 6- SAE 6
6	1	71112254	ASSY, VLV, CTRL, DIR, 24VDC, 3/2, NO
7	1	83107804	BLOCK, STACK, D03, TALL
8	4	21411027	SOCH, 10-24 X 1-1/4, ALY

(SCREWS INCLUDED WITH VALVE)

TORQUE TO
80 IN-LBS
(9 N-M)

PL559523 REV D

SECTION VI

MAINTENANCE (continued)

41.0 VALVE ASSEMBLY, SOLENOID, 24V, 3/2, NORMALLY CLOSED

NO	QTY	PART NO	DESCRIPTION
N/A	N/A	95595424	KIT, VLV, 3/2, 24VDC, NC
1	1	27742201	CABLE, M12 MALE, M12 FEM, 5 POLE, 0.6m
2	1	27742202	ADAPTER, DIN FORM A, M12 MALE
3	2	30601166	PLUG, SOCH, SAE 6
4	2	39000061	O-RING, (-016)
5	1	70040710	ASSY, FILTER, 25 MICRON, SAE 6- SAE 6
6	1	71115003	ASSY, VLV, CTRL, DIR, 24VDC, 3/2, NC
7	1	83107804	BLOCK, STACK, D03, TALL
8	4	21411026	SOCH, 10-24 X 1-1/8, ALY

(8/4) (SCREWS INCLUDED WITH VALVE)

TORQUE TO
80 IN-LBS
(9 N-M)

PL559524 REV D

SECTION VI

MAINTENANCE (continued)

42.0 VALVE ASSEMBLY, SOLENOID, 24V, 3/2, NORMALLY CLOSED, SA, DUMP

NO	QTY	PART NO	DESCRIPTION
N/A	N/A	95595425	KIT, VLV, 3/2, 24VDC, NC, SA, PD, DUMP
1	1	27742201	CABLE, M12 MALE, M12 FEM, 5 POLE, 0.6m
2	1	27742202	ADAPTER, DIN FORM A, M12 MALE
3	1	30162144	ELBOW, 90, SAE 4 MALE - SAE 4 FEM
4	1	30782760	COUPLER, QD, SAE 6, FEM, FLUSH
5	1	30801264	REDUCER, MALE SAE 6 - FEM SAE 4
6	1	35144610	HOSE, HYD, 3/8 X 120
7	2	39000061	O-RING, (-016)
8	1	70040710	ASSY, FILTER, 25 MICRON, SAE 6- SAE 6
9	1	71115003	ASSY, VLV, CTRL, DIR, 24VDC, 3/2, NC
10	1	72212162	GAUGE, PRESS, HYDR, 10000 PSI
11	1	83107805	BLOCK, STACK, D03, TALL, A-B CONNECTED
12	4	21411026	SOCH, 10-24 X 1-1/8, ALY

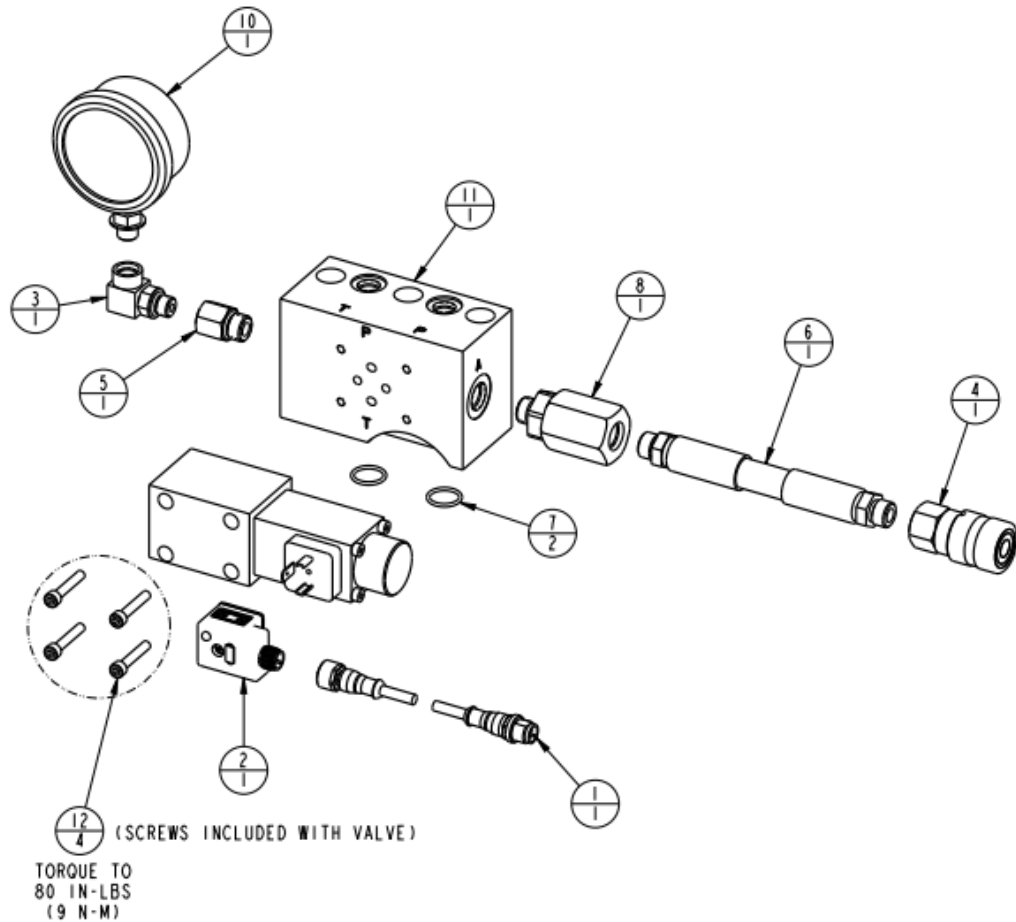
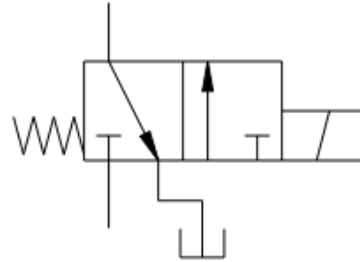

PL559525 REV D

SECTION VI

MAINTENANCE (continued)

43.0 VALVE ASSEMBLY, SOLENOID, 24V, 4/3, CLOSED CENTER

NO	QTY	PART NO	DESCRIPTION
N/A	N/A	95595426	KIT, VLV, 4/3, 24VDC, CC
1	1	27742201	CABLE, M12 MALE, M12 FEM, 5 POLE, 0.6m
2	1	27842200	ADAPTER, DOUBLE DIN FORM A, M12 MALE
3	2	30601166	PLUG, SOCH, SAE 6
4	2	39000061	O-RING, (-016)
5	2	70040710	ASSY, FILTER, 25 MICRON, SAE 6- SAE 6
6	1	71123521	ASSY, VLV, DIR, 24V, 4/3, CC
7	1	83107804	BLOCK, STACK, D03, TALL
8	4	21411027	SOCH, 10-24 X 1-1/4, ALY

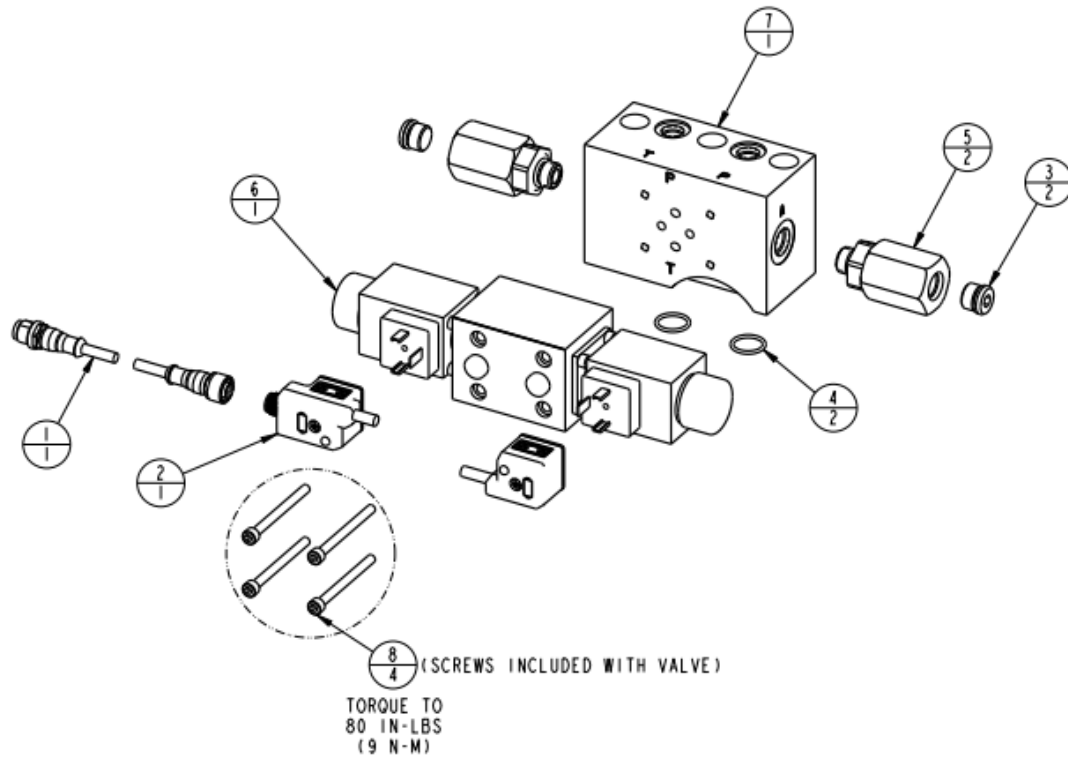
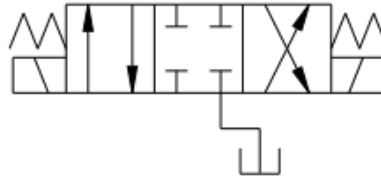

PL559526 REV D

SECTION VI

MAINTENANCE (continued)

44.0 VALVE ASSEMBLY, SOLENOID, 24V, 4/3, PRESSURE BLOCKED CENTER

NO	QTY	PART NO	DESCRIPTION
N/A	N/A	95595427	KIT, VLV, 4/3, 24VDC, PBC
1	1	27742201	CABLE, M12 MALE, M12 FEM, 5 POLE, 0.6m
2	1	27842200	ADAPTER, DOUBLE DIN FORM A, M12 MALE
3	2	30601166	PLUG, SOCH, SAE 6
4	2	39000061	O-RING, (-016)
5	2	70040710	ASSY, FILTER, 25 MICRON, SAE 6- SAE 6
6	1	71123540	ASSY, VLV, CTRL, DIR, 24VDC, 4/3, PBC
7	1	83107804	BLOCK, STACK, D03, TALL
8	4	21410070	SOCH, 10-24 X 2-1/4, ALY

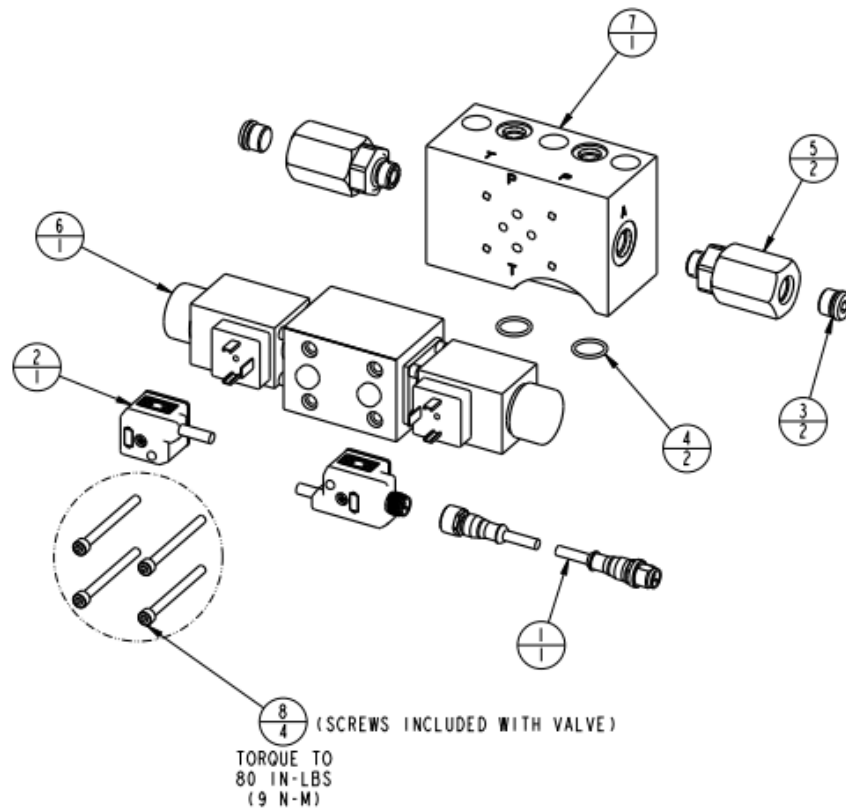
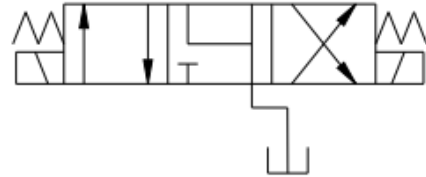

PL559527 REV D

SECTION VI

MAINTENANCE (continued)

45.0 VALVE ASSEMBLY, SOLENOID, 24V, 4/3, PRESSURE BLOCKED CENTER, PRV

NO	QTY	PART NO	DESCRIPTION
N/A	N/A	95595428	KIT, VLV, 4/3, 24VDC, PBC, RAB
1	4	21410013	SCREW, CAP, SOCH, 10-24 X 4-1/4, ALY
2	1	27742201	CABLE, M12 MALE, M12 FEM, 5 POLE, 0.6m
3	1	27842200	ADAPTER, DOUBLE DIN FORM A, M12 MALE
4	2	30601166	PLUG, SOCH, SAE 6
5	2	39000061	O-RING, (-016)
6	4	55250005	O-RING, (-011)
7	2	70040710	ASSY, FILTER, 25 MICRON, SAE 6- SAE 6
8	2	70543770	ASSY, CARTRIDGE, PRV
9	1	70842550	ASSY, CONTROL BLOCK, PRV, DBL, D03
10	1	71123540	ASSY, VLV, CTRL, DIR, 24VDC, 4/3, PBC
11	1	83107804	BLOCK, STACK, D03, TALL
12	1	87084200	BODY, SANDWICH, D03, PRV

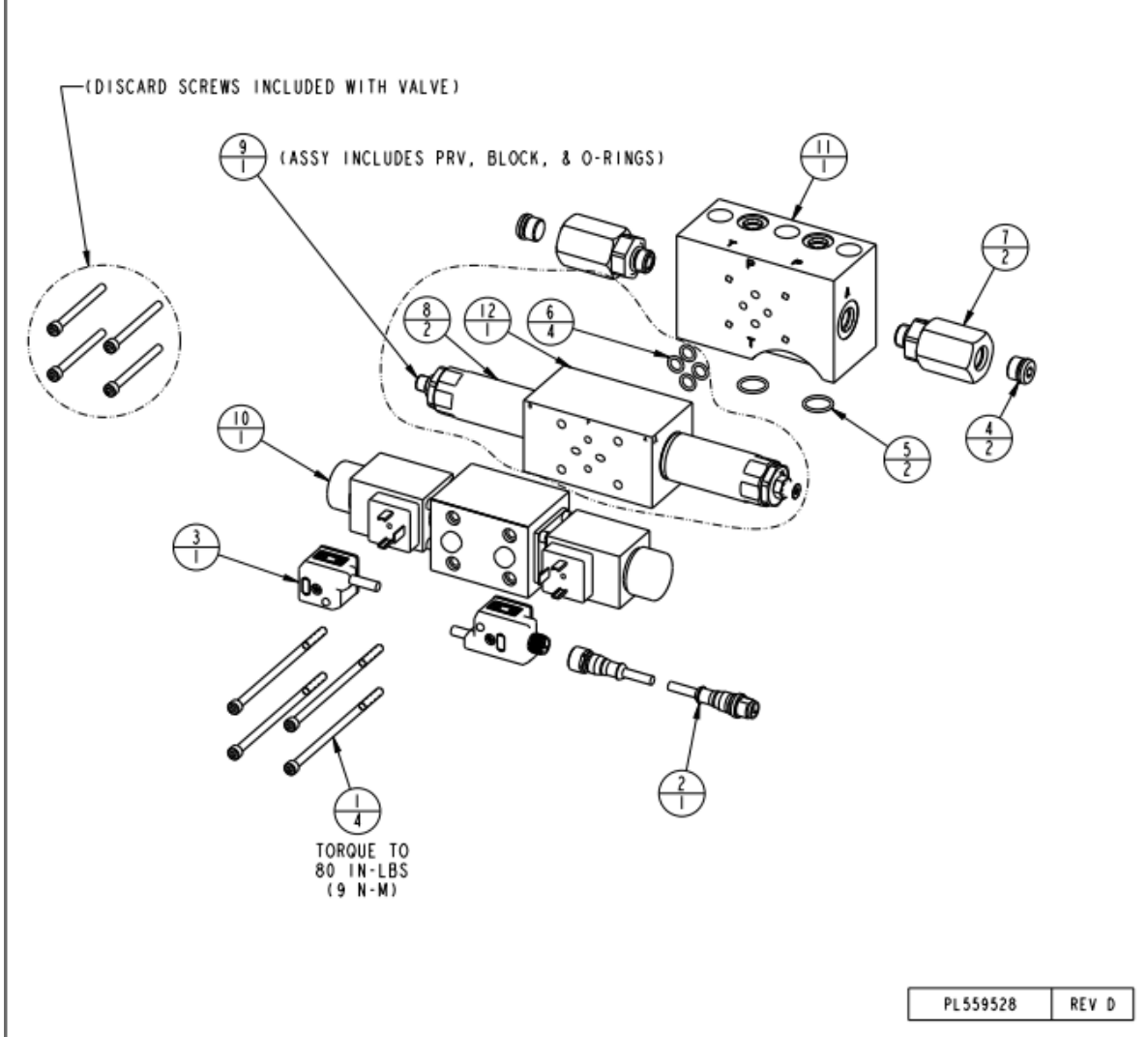
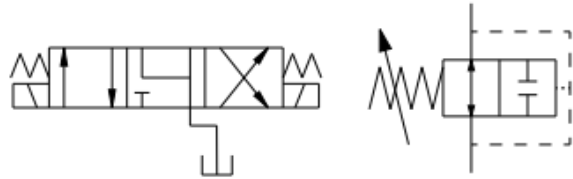

SECTION VI

MAINTENANCE (continued)

46.0 GAUGE ASSEMBLY, A-B TAPPING PLATE

NO	QTY	PART NO	DESCRIPTION
N/A	N/A	95595451	KIT, GA, GAUGE, 10,000 PSI, A PORT
N/A	N/A	95595452	KIT, GB, GAUGE, 10,000 PSI, B PORT
N/A	N/A	95595453	KIT, GAB, GAUGE, 10,000 PSI, A-B PORT
1	1	30601144	PLUG, SOCH, SAE 4
2	4	55250005	O-RING, (-011)
3	1	70942500	ASSY, PLATE, TAPPING, A-B, D03, THICK
4	1	72212162	GAUGE, PRESS, HYDR, 10000 PSI

PL559529 REV A

SECTION VI

MAINTENANCE (continued)

47.0 MECHANICAL PRESSURE SWITCH ASSEMBLY, A-B TAPPING PLATE

NO	QTY	PART NO	DESCRIPTION
N/A	N/A	95595454	KIT, PA, MECH PRESS SWITCH, A PORT
N/A	N/A	95595455	KIT, PB, MECH PRESS SWITCH, B PORT
N/A	N/A	95595456	KIT, PAB, MECH PRESS SWITCH, A-B PORT
1	1	27642400	CORDSET, FEMALE, 3 PIN, M8, 5 M
2	1	30162144	ELBOW, 90, SAE 4 MALE - SAE 4 FEM
3	1	30231244	TEE, RUN, SAE 4 FEM - SAE 4 MALE
4	1	30601144	PLUG, SOCH, SAE 4
5	4	55250005	O-RING, (-011)
6	1	70750074	ASSY, SWITCH, PRESS, M8 MALE
7	1	70942500	ASSY, PLATE, TAPPING, A-B, D03, THICK
8	1	72122155	GAUGE, PRESS, HYDR, 6000 PSI, CBM

(ASSY INCLUDES O-RINGS)

PL559530 REV B

SECTION VI

MAINTENANCE (continued)

48.0 MECHANICAL PRESSURE SWITCH ASSEMBLY, A-B TAPPING PLATE, MACHINE CONTROL INTERFACE

NO	QTY	PART NO	DESCRIPTION
N/A	N/A	95595460	KIT, PA, MECH PRESS SWITCH, A PORT, MC
N/A	N/A	95595461	KIT, PB, MECH PRESS SWITCH, B PORT, MC
1	1	30162144	ELBOW, 90, SAE 4 MALE - SAE 4 FEM
2	1	30231244	TEE, RUN, SAE 4 FEM - SAE 4 MALE
3	1	30601144	PLUG, SOCH, SAE 4
4	4	55250005	O-RING, (-011)
5	1	70750074	ASSY, SWITCH, PRESS, M8 MALE
6	1	70942500	ASSY, PLATE, TAPPING, A-B, DO3, THICK
7	1	72122155	GAUGE, PRESS, HYDR, 6000 PSI, CBM
8	1	95595600	AY, CABLE, M12 MALE, M8 FEM

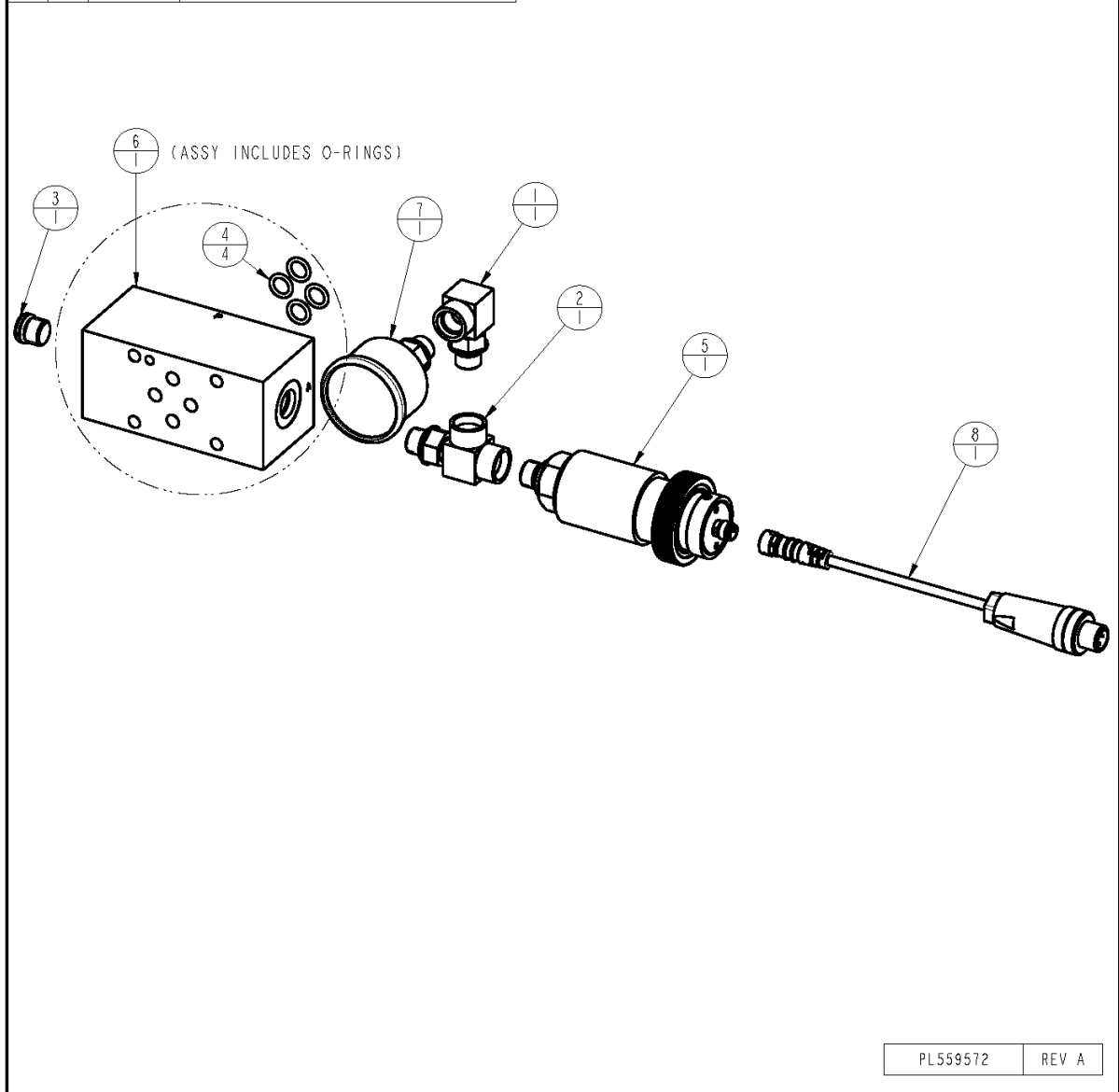
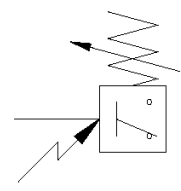

PL559572 REV A

SECTION VI

MAINTENANCE (continued)

49.0 DUAL MECHANICAL PRESSURE SWITCH ASSEMBLY, A-B TAPPING PLATE, MACHINE CONTROL INTERFACE

NO	QTY	PART NO	DESCRIPTION
N/A	N/A	95595462	KIT, PAB, MECH PRESS SWITCH, A-B PORT, MC
1	2	30162144	ELBOW, 90, SAE 4 MALE - SAE 4 FEM
2	2	30231244	TEE, RUN, SAE 4 FEM - SAE 4 MALE
3	4	55250005	O-RING, (-011)
4	2	70750074	ASSY, SWITCH, PRESS, M8 MALE
5	1	70942500	ASSY, PLATE, TAPPING, A-B, D03, THICK
6	2	72122155	GAUGE, PRESS, HYDR, 6000 PSI, CBM
7	1	95595601	AY, CABLE, M12 MALE, DOUBLE M8 FEM

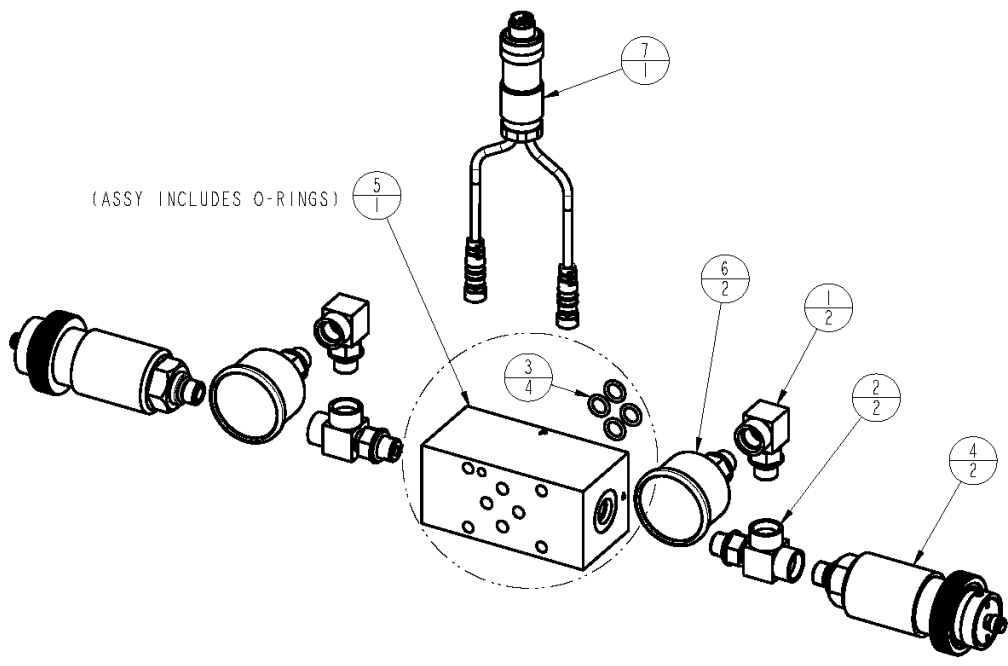
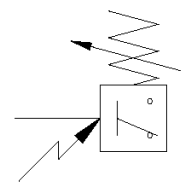

PL559573 REV A

SECTION VI

MAINTENANCE (continued)

50.0 ELECTRICAL PRESSURE SWITCH ASSEMBLY, A-B TAPPING PLATE

NO	QTY	PART NO	DESCRIPTION
N/A	N/A	95595457	KIT, QA, ELECT PRESS SWITCH, A PORT
N/A	N/A	95595458	KIT, QB, ELECT PRESS SWITCH, B PORT
N/A	N/A	95595459	KIT, QAB, ELECT PRESS SWITCH, A-B PORT
1	1	27742203	CABLE, M12 MALE, M12 FEMALE, 5 POLE, 5M
2	1	30601144	PLUG, SOCH, SAE 4
3	4	55250005	O-RING, (-011)
4	1	70740075	SWITCH, PRESSURE, ELCT, 5800 PSI, SAE 4
5	1	70942500	ASSY, PLATE, TAPPING, A-B, D03, THICK
6	N/A	IS7075	INSTRUCTION SHEET, ELECT PRESS SWITCH

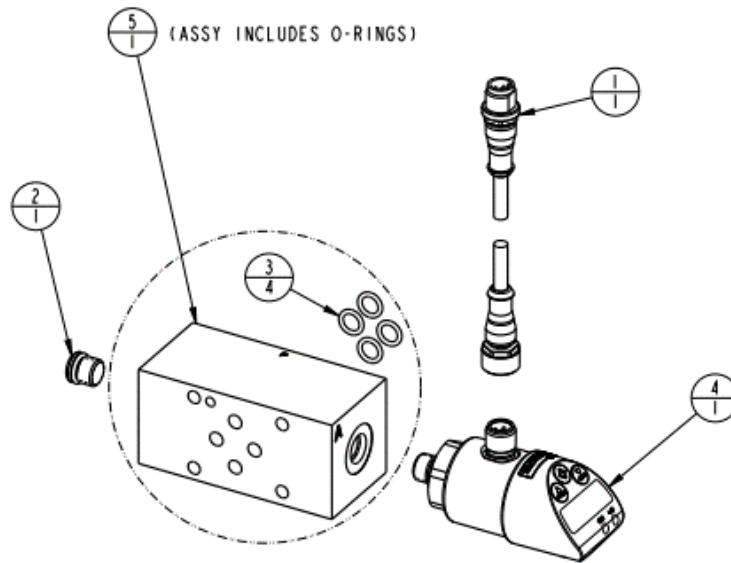
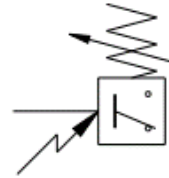

NOTE:
 1. PROGRAM I.A.W IS7079 WITH THE FOLLOWING EXCEPTIONS:
 A. CHANGE OUTPUT 1 (Out1) TO H_{no} (NORMALLY OPEN).
 C. CHANGE FUNCTION DISPLAY DISR TO YES.
 D. METRIC PUMPS ONLY, CHANGE UNITS (uni) TO BAR.

PL559531	REV C
----------	-------

SECTION VI

MAINTENANCE (continued)

51.0 ELECTRICAL PRESSURE SWITCH ASSEMBLY, A-B TAPPING PLATE, MACHINE INTERFACE CONTROL

NO	QTY	PART NO	DESCRIPTION
N/A	N/A	95595463	KIT, QA, ELECT PRESS SWITCH, A PORT, MC
N/A	N/A	95595464	KIT, QB, ELECT PRESS SWITCH, B PORT, MC
1	1	27742204	CABLE, M12 MALE, M12 FEM, 4 POL, 0.6M
2	1	30601144	PLUG, SOCH, SAE 4
3	4	55250005	O-RING, (-011)
4	1	70740075	SWITCH, PRESSURE, ELCT, 5800 PSI, SAE 4
5	1	70942500	ASSY, PLATE, TAPPING, A-B, D03, THICK
6	N/A	1S7075	INSTRUCTION SHEET, ELECT PRESS SWITCH

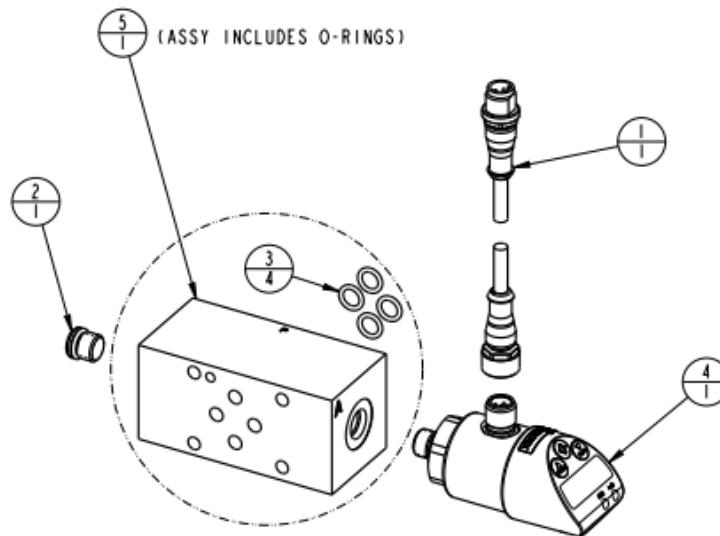
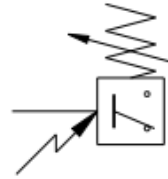

NOTE:
 I. PROGRAM I.A.W 1S7079 WITH THE FOLLOWING EXCEPTIONS:
 A. CHANGE OUTPUT 1 (Ou1) TO Hoo (NORMALLY OPEN).
 C. CHANGE FUNCTION DISPLAY DISR to YES.
 D. METRIC PUMPS ONLY, CHANGE UNITS (uni) TO BAR.

PL559574	REV B
----------	-------

SECTION VI

MAINTENANCE (continued)

52.0 DUAL ELECTRICAL PRESSURE SWITCH ASSEMBLY, A-B TAPPING PLATE, MACHINE INTERFACE CONTROL

NO	QTY	PART NO	DESCRIPTION
N/A	N/A	95595465	KIT, QAB, ELECT PRESS SWITCH, A-B PORT, MC
1	1	27842201	ADAPTER, M12 MALE 4 PIN 0", 2X M12 FEM 0"
2	4	55250005	O-RING, (-011)
3	2	70740075	SWITCH, PRESSURE, ELCT, 5800 PSI, SAE 4
4	1	70942500	ASSY, PLATE, TAPPING, A-B, DO3, THICK
6	N/A	IS7075	INSTRUCTION SHEET, ELECT PRESS SWITCH

(ASSY INCLUDES O-RINGS)

NOTE:
 1. PROGRAM I.A.W IS7079 WITH THE FOLLOWING EXCEPTIONS:
 A. CHANGE OUTPUT 1 (Ou1) TO Hno (NORMALLY OPEN).
 C. CHANGE FUNCTION DISPLAY DISR to YES.
 D. METRIC PUMPS ONLY, CHANGE UNITS (uni) TO BAR.

PL559575 REV B

SECTION VI

MAINTENANCE (continued)

53.0 NPN ELECTRICAL PRESSURE SWITCH ASSEMBLY, A-B TAPPING PLATE

NO	QTY	PART NO	DESCRIPTION
N/A	N/A	95595466	KIT, NPN, ELECT PRESS SWITCH, A PORT
N/A	N/A	95595467	KIT, NPN, ELECT PRESS SWITCH, B PORT
N/A	N/A	95595468	KIT, NPN, ELECT PRESS SWITCH, A-B PORT
1	1	27742203	CABLE, M12 MALE, M12 FEMALE, 5 POLE, 5M
2	1	30601144	PLUG, SOCH, SAE 4
3	4	55250005	O-RING, (-011)
4	1	70740075	SWITCH, PRESSURE, ELCT, 5800 PSI, SAE 4
5	1	70942500	ASSY, PLATE, TAPPING, A-B, D03, THICK
6	N/A	1S7075	INSTRUCTION SHEET, ELECT PRESS SWITCH

(ASSY INCLUDES O-RINGS)

NOTE:
 1. PROGRAM I.A.W 1S7079 WITH THE FOLLOWING EXCEPTIONS:
 A. CHANGE OUTPUT 1 (Out) TO Hno (NORMALLY OPEN).
 B. CHANGE SWITCHING LOGIC POL1 AND POL2 TO NPN.
 C. CHANGE FUNCTION DISPLAY DISR TO YES.
 D. METRIC PUMPS ONLY, CHANGE UNITS (uni) TO BAR.

PL559578 REV B

SECTION VI

MAINTENANCE (continued)

54.0 PRESSURE REDUCING VALVE ASSEMBLY

NO	QTY	PART NO	DESCRIPTION
N/A	N/A	70842551	ASSY, CONTROL BLOCK, PRV, A PORT
N/A	N/A	70842554	ASSY, CONTROL BLOCK, PRV, B PORT
N/A	N/A	70842550	ASSY, CONTROL BLOCK, PRV, A-B PORT
1	1	30601199	PLUG, SOCH, SAE 10
2	4	55250005	O-RING, (-O11)
3	1	70543770	ASSY, CARTRIDGE, PRV
4	1	87084200	BODY, SANDWICH, D03, PRV

PL559532 REV A

SECTION VI

MAINTENANCE (continued)

55.0 PO CHECK VALVE, D03

NO	QTY	PART NO	DESCRIPTION
N/A	N/A	95595430	ASSY, VLV, A PO CHECK, D03, CA
N/A	N/A	95595431	ASSY, VLV, B PO CHECK, D03, CB
N/A	N/A	95595432	ASSY, VLV, A-B PO CHECK, D03, CAB
1	6	27412011	PLUG, EXPANSION, PULL-TYPE, 5mm
2	4	39050042	O-RING, (-011)
3	1	70333771	ASSY, VLV, PO CHECK, CM
4	1	85595403	BODY, VLV, A-B PO CHECK, D03, I. 75 SQ
5	1	95595429	ASSY, PLUG, VLV, A-B PO CHECK, D03

NOTES:
1. CLEAN HOLES AND POCKETS BEFORE INSTALLING PLUGS.

PL559579 REV B

SECTION VI

MAINTENANCE (continued)

56.0 MACHINE INTERFACE CONTROL, 1-4 VALVE

NO	QTY	PART NO	DESCRIPTION
N/A	N/A	95595523	KIT, AWP, MC, 1-4 VLV
1	2	21410049	SCREW, CAP, SOCH, 8-32 X 3/8, ALY
2	4	21410073	SCREW, CAP, SOCH, 10-32 X 0.375
3	2	21410096	SCREW, CAP, SOCH, 1/4-20 X 1/4, ALY
4	2	28615600	STRAIN RELIEF, CABLE, M25
5	1	85595524	BLOCK, I/O, M12, MC
6	1	85595536	BRACKET, MOUNT, CONNECTOR
7	1	85595557	BASE, CONNECTOR, PUMP, MC, M25
8	1	95595525	ASSY, CONNECTOR, MALE AND I/O, MC
9	1	95595526	ASSY, CABLE, MALE, FEMALE, MC

SEE FINAL ASSEMBLY FOR MC FEMALE CONNECTOR

PL559569	REV B
----------	-------

SECTION VI

MAINTENANCE (continued)

57.0 MACHINE INTERFACE CONTROL, 5-6 VALVE

NO	QTY	PART NO	DESCRIPTION
N/A	N/A	95595602	KIT, AWP, MC, 5-6 VLV
1	4	21410049	SCREW, CAP, SOCH, 8-32 X 3/8, ALY
2	4	21410073	SCREW, CAP, SOCH, 10-32 X 0.375
3	2	21410096	SCREW, CAP, SOCH, 1/4-20 X 1/4, ALY
4	1	28615600	STRAIN RELIEF, CABLE, M25
5	4	28645001	CAP, PORT, PLASTIC, M12
6	2	85595524	BLOCK, I/O, M12, MC
7	1	85595536	BRACKET, MOUNT, CONNECTOR
8	1	85595558	REDUCER, M32 - M25
9	1	95595604	AY, CONNECTOR, MALE AND I/O, MC, XV
10	1	95595605	AY, CABLE, MALE, FEMALE, MC, XV

SEE FINAL ASSEMBLY FOR MC FEMALE CONNECTOR

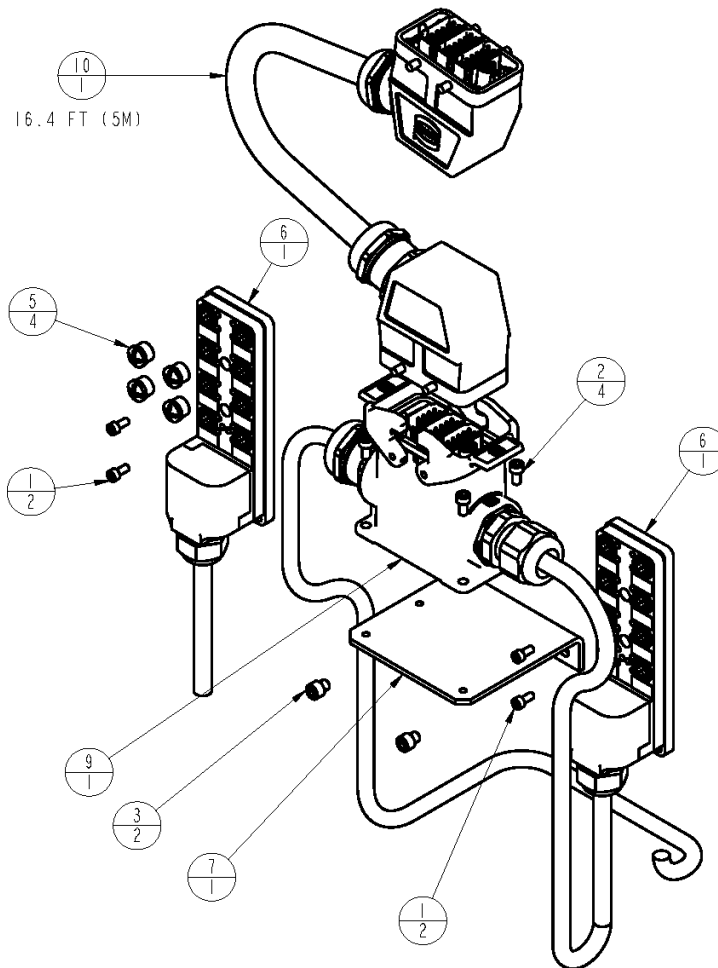

PL559570

REV B

SECTION VI

MAINTENANCE (continued)

58.0 MACHINE INTERFACE CONTROL, 1-4 VALVE WITH POWER

NO	QTY	PART NO	DESCRIPTION
N/A	N/A	95595616	KIT, AWP, MC, 1-4 VLV, PWR
1	2	21410049	SCREW, CAP, SOCH, 8-32 X 3/8, ALY
2	4	21410073	SCREW, CAP, SOCH, 10-32 X 0.375
3	2	21410096	SCREW, CAP, SOCH, 1/4-20 X 1/4, ALY
4	1	85595524	BLOCK, I/O, M12, MC
5	1	85595536	BRACKET, MOUNT, CONNECTOR
6	1	95595618	ASSY, CONNECTOR, MALE, I/O, MC, PWR
7	1	95595619	ASSY, CABLE, MALE, FEMALE MC, PWR

SEE FINAL ASSEMBLY FOR MC FEMALE CONNECTOR

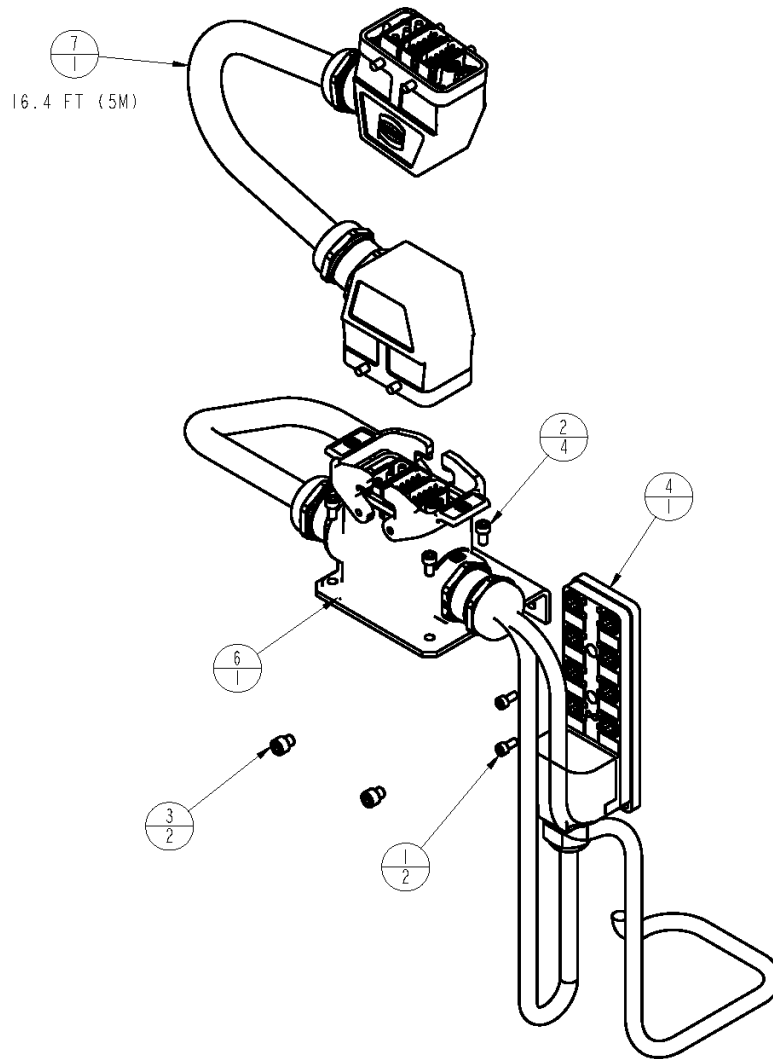

PL559571 REV B

SECTION VI

MAINTENANCE (continued)

59.0 ELECTRICAL ENCLOSURE, 1- PHASE 100-120VAC, NO VALVE POWER

NO	QTY	PART NO	DESCRIPTION
N/A	N/A	95595504	AY, ENCL, 1HP, IP, 100-120V, NP
1	7	21411025	SCREW, #8-32 UNC-2AX.5, SELF-TAPPING
2	1	27511200	CABLE, POWER, 12-3, 8 FT
3	1	27642300	RECEPTACLE, FEM, M8, 4 POLE
4	1	28615600	STRAIN RELIEF, CABLE, M25
5	1	28625600	STRAIN RELIEF, 90°, HINGED, M25
6	2	28645000	NUT, LOCK, NYLON, M25
7	4	28731124	BLOCK, WAGO, 2 WIRE
8	1	28731126	BLOCK, WAGO, 4 WIRE
9	2	28731128	BLOCK, END, 35MM RAIL
10	1	28731146	END PLATE, WAGO TERMINAL BLOCK
11	2	28731147	PLUG, LIQUID TIGHT, 1/2 CONDUIT
12	1	28731162	RECEPTACLE, FEM, M12, 5 POLE
13	1	29133100	SWITCH, SELECTOR, MNTD-OFF-MOM
14	1	29133101	BASE, SWITCH, 2 NO CONTACTS
15	1	29142200	HEAD, PUSHBUTTON, LED, RED
16	1	29142201	BASE, SWITCH, 1 NO/ 1 NC, LED
17	1	67040074	DECAL, SWITCHES, PUMP
18	1	67040075	DECAL, CONNECTIONS, PUMP
19	1	85595500	ENCLOSURE, FIBERGLASS, 12X10X6
20	1	85595501	PANEL, BACK, ELECTRICAL, VFD
21	2	85595502	RAIL, DIN, 35 MM X 4.5
22	1	85595503	BLOCK, DISTRIBUTION, 1/4
23	1	85595507	DRIVE, AC, 1-PH, 100-120 VAC, 1-HP
24	1	85595508	BREAKER, CIRCUIT, 1 POL, 240V, 20A

NOTE: 1. WIRES AND ENCLOSURE LID REMOVED FOR CLARITY.
 2. LOAD PROGRAM PRG5500 I.A.W. EN5512 USING MULTILoader BEFORE SHIPMENT.

PL559537	REV B
----------	-------

SECTION VI

MAINTENANCE (continued)

60.0 ELECTRICAL ENCLOSURE, 3- PHASE 200-240VAC, NO VALVE POWER

NO	QTY	PART NO	DESCRIPTION
N/A	N/A	95595510	AY, ENCL, 1HP, 3P, 200-240V, NP
1	7	21411025	SCREW, #8-32 UNC-2AX.5, SELF-TAPPING
2	1	27642300	RECEPTACLE, FEM, M8, 4 POLE
3	1	28615600	STRAIN RELIEF, CABLE, M25
4	1	28625600	STRAIN RELIEF, 90°, HINGED, M25
5	2	28645000	NUT, LOCK, NYLON, M25
6	4	28731124	BLOCK, WAGO, 2 WIRE
7	1	28731126	BLOCK, WAGO, 4 WIRE
8	2	28731128	BLOCK, END, 35MM RAIL
9	1	28731146	END PLATE, WAGO TERMINAL BLOCK
10	2	28731147	PLUG, LIQUID TIGHT, 1/2 CONDUIT
11	1	28731162	RECEPTACLE, FEM, M12, 5 POLE
12	1	29133100	SWITCH, SELECTOR, MNTD-OFF-MOM
13	1	29133101	BASE, SWITCH, 2 NO CONTACTS
14	1	29142200	HEAD, PUSHBUTTON, LED, RED
15	1	29142201	BASE, SWITCH, 1 NO/ 1 NC, LED
16	1	67040074	DECAL, SWITCHES, PUMP
17	1	67040075	DECAL, CONNECTIONS, PUMP
18	1	85595500	ENCLOSURE, FIBERGLASS, 12X10X6
19	1	85595501	PANEL, BACK, ELECTRICAL, VFD
20	2	85595502	RAIL, DIN, 35 MM X 4.5
21	1	85595515	DRIVE, AC, 3-PH, 200-240 VAC, 1-HP
22	1	85595516	BREAKER, CIRCUIT, 3 POL, 240V, 7A

NOTE: 1. WIRES AND ENCLOSURE LID REMOVED FOR CLARITY.
 2. LOAD PROGRAM PRG5502 I.A.W. EN5512 USING MULTILOADER BEFORE SHIPMENT.

RETAINING NUT INCLUDED

RETAINING NUT INCLUDED

SEE NOTE 2

PL559539 REV B

SECTION VI

MAINTENANCE (continued)

61.0 ELECTRICAL ENCLOSURE, 3 PHASE 380-500VAC, NO VAL

NO	QTY	PART NO	DESCRIPTION
N/A	N/A	95595511	AY, ENCL, 1HP, 3P, 380-500V, NP
1	7	21411025	SCREW, #8-32 UNC-2AX.5, SELF-TAPPING
2	1	27642300	RECEPTACLE, FEM, M8, 4 POLE
3	1	28615600	STRAIN RELIEF, CABLE, M25
4	1	28625600	STRAIN RELIEF, 90°, HINGED, M25
5	2	28645000	NUT, LOCK, NYLON, M25
6	4	28731124	BLOCK, WAGO, 2 WIRE
7	1	28731126	BLOCK, WAGO, 4 WIRE
8	2	28731128	BLOCK, END, 35MM RAIL
9	1	28731146	END PLATE, WAGO TERMINAL BLOCK
10	2	28731147	PLUG, LIQUID TIGHT, 1/2 CONDUIT
11	1	28731162	RECEPTACLE, FEM, M12, 5 POLE
12	1	29133100	SWITCH, SELECTOR, MNTD-OFF-MOM
13	1	29133101	BASE, SWITCH, 2 NO CONTACTS
14	1	29142200	HEAD, PUSHBUTTON, LED, RED
15	1	29142201	BASE, SWITCH, 1 NO/ 1 NC, LED
16	1	67040074	DECAL, SWITCHES, PUMP
17	1	67040075	DECAL, CONNECTIONS, PUMP
18	1	85595500	ENCLOSURE, FIBERGLASS, 12X10X6
19	1	85595501	PANEL, BACK, ELECTRICAL, VFD
20	2	85595502	RAIL, DIN, 35 MM X 4.5
21	1	85595549	DRIVE, AC, 3-PH, 380-500 VAC, 2-HP
22	1	85595550	BREAKER, CIRCUIT, MOTOR, 3-POL, 10A

NOTE: 1. WIRES AND ENCLOSURE LID REMOVED FOR CLARITY.
 2. LOAD PROGRAM PRG5504 I.A.W. EN5512 USING MULTILoader BEFORE SHIPMENT.

PL559540	REV C
----------	-------

SECTION VI

MAINTENANCE (continued)

62.0 ELECTRICAL ENCLOSURE, 3 PHASE 525-600VAC, NO VALVE POWER

NO	QTY	PART NO	DESCRIPTION
N/A	N/A	95595630	AY, ENCL, IHP, 3P, 525-600V, NP
1	7	21411025	SCREW, #8-32 UNC-2AX.5, SELF-TAPPING
2	1	27642300	RECEPTACLE, FEM, M8, 4 POLE
3	1	28615600	STRAIN RELIEF, CABLE, M25
4	1	28625600	STRAIN RELIEF, 90°, HINGED, M25
5	2	28645000	NUT, LOCK, NYLON, M25
6	4	28731124	BLOCK, WAGO, 2 WIRE
7	1	28731126	BLOCK, WAGO, 4 WIRE
8	2	28731128	BLOCK, END, 35MM RAIL
9	1	28731146	END PLATE, WAGO TERMINAL BLOCK
10	2	28731147	PLUG, LIQUID TIGHT, 1/2 CONDUIT
11	1	28731162	RECEPTACLE, FEM, M12, 5 POLE
12	1	29133100	SWITCH, SELECTOR, MNTD-OFF-MOM
13	1	29133101	BASE, SWITCH, 2 NO CONTACTS
14	1	29142200	HEAD, PUSHBUTTON, LED, RED
15	1	29142201	BASE, SWITCH, 1 NO/ 1 NC, LED
16	1	67040074	DECAL, SWITCHES, PUMP
17	1	67040075	DECAL, CONNECTIONS, PUMP
18	1	85595500	ENCLOSURE, FIBERGLASS, 12X10X6
19	1	85595501	PANEL, BACK, ELECTRICAL, VFD
20	2	85595502	RAIL, DIN, 35 MM X 4.5
21	1	85595564	DRIVE, AC, 3-PH, 525-600 VAC, 1-HP
22	1	85595565	BREAKER, CIRCUIT, MOTOR, 3-POL, 1.6-2.5A

NOTE: 1. WIRES AND ENCLOSURE LID REMOVED FOR CLARITY.
 2. LOAD PROGRAM PRG5507 I.A.W. EN5512 USING MULTILoader BEFORE SHIPMENT.

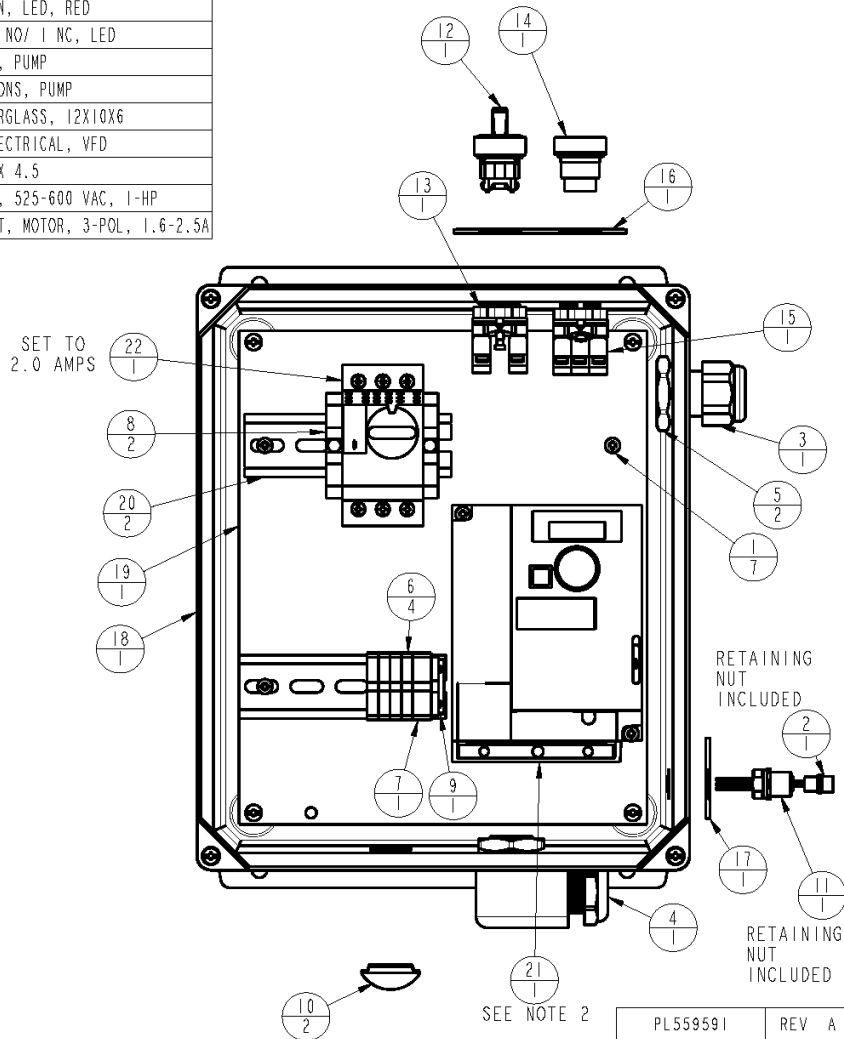

SECTION VI

MAINTENANCE (continued)

63.0 ELECTRICAL ENCLOSURE, 1-PHASE 100-120VAC, PENDANT CONTROL

NO	QTY	PART NO	DESCRIPTION
N/A	N/A	95595514	AY, ENCL, 1HP, IP, 100-120V, 24V
1	7	21411025	SCREW, #8-32 UNC-2AX.5, SELF-TAPPING
2	1	27511200	CABLE, POWER, 12-3, 8 FT
3	1	27642300	RECEPTACLE, FEM, M8, 4 POLE
4	1	28512400	RELIEF, STRAIN, CORD, 1/2 NPT
5	1	28542000	NUT, LOCK, 1/2 NPT
6	1	28615600	STRAIN RELIEF, CABLE, M25
7	1	28625600	STRAIN RELIEF, 90°, HINGED, M25
8	2	28645000	NUT, LOCK, NYLON, M25
9	4	28731124	BLOCK, WAGO, 2 WIRE
10	1	28731126	BLOCK, WAGO, 4 WIRE
11	2	28731128	BLOCK, END, 35MM RAIL
12	1	28731146	END PLATE, WAGO TERMINAL BLOCK
13	1	28731147	PLUG, LIQUID TIGHT, 1/2 CONDUIT
14	1	28731162	RECEPTACLE, FEM, M12, 5 POLE
15	1	29133100	SWITCH, SELECTOR, MNTO-OFF-MOM
16	1	29133101	BASE, SWITCH, 2 NO CONTACTS
17	1	29142200	HEAD, PUSHBUTTON, LED, RED
18	1	29142201	BASE, SWITCH, 1 NO/ 1 NC, LED
19	1	67040074	DECAL, SWITCHES, PUMP
20	1	67040075	DECAL, CONNECTIONS, PUMP
21	1	85595500	ENCLOSURE, FIBERGLASS, 12X10X6
22	1	85595501	PANEL, BACK, ELECTRICAL, VFD
23	2	85595502	RAIL, DIN, 35 MM X 4.5
24	1	85595503	BLOCK, DISTRIBUTION, 1/4
25	1	85595504	POWER SUPPLY, 24V, 120W
26	1	85595507	DRIVE, AC, 1-PH, 100-120 VAC, 1-HP
27	1	85595508	BREAKER, CIRCUIT, 1 POL, 240V, 20A
28	1	85595509	BREAKER, CIRCUIT, 1 POL, 240V, 3A

NOTE: 1. WIRES AND ENCLOSURE LID REMOVED FOR CLARITY.
 2. LOAD PROGRAM PRG5500 I.A.W. EN5512 USING MULTILOADER BEFORE SHIPMENT.

PL559541
REV B

SECTION VI

MAINTENANCE (continued)

64.0 ELECTRICAL ENCLOSURE, 3-PHASE 200-240VAC, PENDANT CONTROL

NO	QTY	PART NO	DESCRIPTION
N/A	N/A	95595520	AY, ENCL, 1HP, 3P, 200-240V, 24V
1	7	21411025	SCREW, #8-32 UNC-2AX.5, SELF-TAPPING
2	1	27642300	RECEPTACLE, FEM, M8, 4 POLE
3	1	28512400	RELIEF, STRAIN, CORD, 1/2 NPT
4	1	28542000	NUT, LOCK, 1/2 NPT
5	1	28615600	STRAIN RELIEF, CABLE, M25
6	1	28625600	STRAIN RELIEF, 90°, HINGED, M25
7	2	28645000	NUT, LOCK, NYLON, M25
8	4	28731124	BLOCK, WAGO, 2 WIRE
9	1	28731126	BLOCK, WAGO, 4 WIRE
10	2	28731128	BLOCK, END, 35MM RAIL
11	1	28731146	END PLATE, WAGO TERMINAL BLOCK
12	1	28731147	PLUG, LIQUID TIGHT, 1/2 CONDUIT
13	1	28731162	RECEPTACLE, FEM, M12, 5 POLE
14	1	29133100	SWITCH, SELECTOR, MNTO-OFF-MOM
15	1	29133101	BASE, SWITCH, 2 NO CONTACTS
16	1	29142200	HEAD, PUSHBUTTON, LED, RED
17	1	29142201	BASE, SWITCH, 1 NO/ 1 NC, LED
18	1	67040074	DECAL, SWITCHES, PUMP
19	1	67040075	DECAL, CONNECTIONS, PUMP
20	1	85595500	ENCLOSURE, FIBERGLASS, 12X10X6
21	1	85595501	PANEL, BACK, ELECTRICAL, VFD
22	2	85595502	RAIL, DIN, 35 MM X 4.5
23	1	85595504	POWER SUPPLY, 24V, 120W
24	1	85595513	BREAKER, CIRCUIT, 2 POLE, 240V, 2A
25	1	85595515	DRIVE, AC, 3-PH, 200-240 VAC, 1-HP
26	1	85595516	BREAKER, CIRCUIT, 3 POL, 240V, 7A

NOTE: 1. WIRES AND ENCLOSURE LID REMOVED FOR CLARITY.
 2. LOAD PROGRAM PRG5502 I.A.W. EN5512 USING MULTILoader BEFORE SHIPMENT.

RETAINING NUT INCLUDED

RETAINING NUT INCLUDED

SEE NOTE 2

PL559543 REV B

SECTION VI

MAINTENANCE (continued)

65.0 ELECTRICAL ENCLOSURE, 3-PHASE 380-500VAC, PENDANT CONTROL

NO	QTY	PART NO	DESCRIPTION
N/A	N/A	95595522	AY, ENCL, 1HP, 3P, 380-500V, 24W
1	7	21411025	SCREW, #8-32 UNC-2AX.5, SELF-TAPPING
2	1	27642300	RECEPTACLE, FEM, M8, 4 POLE
3	1	28512400	RELIEF, STRAIN, CORD, 1/2 NPT
4	1	28542000	NUT, LOCK, 1/2 NPT
5	1	28615600	STRAIN RELIEF, CABLE, M25
6	1	28625600	STRAIN RELIEF, 90°, HINGED, M25
7	2	28645000	NUT, LOCK, NYLON, M25
8	4	28731124	BLOCK, WAGO, 2 WIRE
9	1	28731126	BLOCK, WAGO, 4 WIRE
10	2	28731128	BLOCK, END, 35MM RAIL
11	1	28731146	END PLATE, WAGO TERMINAL BLOCK
12	1	28731147	PLUG, LIQUID TIGHT, 1/2 CONDUIT
13	1	28731162	RECEPTACLE, FEM, M12, 5 POLE
14	1	29133100	SWITCH, SELECTOR, MNNTD-OFF-MOM
15	1	29133101	BASE, SWITCH, 2 NO CONTACTS
16	1	29142200	HEAD, PUSHBUTTON, LED, RED
17	1	29142201	BASE, SWITCH, 1 NO/ 1 NC, LED
18	1	67040074	DECAL, SWITCHES, PUMP
19	1	67040075	DECAL, CONNECTIONS, PUMP
20	1	85595500	ENCLOSURE, FIBERGLASS, 12X10X6
21	1	85595501	PANEL, BACK, ELECTRICAL, VFD
22	2	85595502	RAIL, DIN, 35 MM X 4.5
23	1	85595504	POWER SUPPLY, 24V, 120W
24	1	85595519	BREAKER, CIRCUIT, MOTOR, 3-POL, 1-1.6A
25	1	85595549	DRIVE, AC, 3-PH, 380-500 VAC, 2-HP
26	1	85595550	BREAKER, CIRCUIT, MOTOR, 3-POL, 10A

NOTE: 1. WIRES AND ENCLOSURE LID REMOVED FOR CLARITY.
 2. LOAD PROGRAM PRG5504 I.A.W. EN5512 USING MULTILOADER BEFORE SHIPMENT.

SEE NOTE 2

PL559544 REV C

SECTION VI

MAINTENANCE (continued)

66.0 ELECTRICAL ENCLOSURE, 3-PHASE 525-600VAC, PENDANT CONTROL

NO	QTY	PART NO	DESCRIPTION
N/A	N/A	95595632	AY, ENCL, IHP, 3P, 525-600V, 24V
1	7	21411025	SCREW, #8-32 UNC-2AX.5, SELF-TAPPING
2	1	27642300	RECEPTACLE, FEM, M8, 4 POLE
3	1	28512400	RELIEF, STRAIN, CORD, 1/2 NPT
4	1	28542000	NUT, LOCK, 1/2 NPT
5	1	28615600	STRAIN RELIEF, CABLE, M25
6	1	28625600	STRAIN RELIEF, 90°, HINGED, M25
7	2	28645000	NUT, LOCK, NYLON, M25
8	4	28731124	BLOCK, WAGO, 2 WIRE
9	1	28731126	BLOCK, WAGO, 4 WIRE
10	2	28731128	BLOCK, END, 35MM RAIL
11	1	28731146	END PLATE, WAGO TERMINAL BLOCK
12	1	28731147	PLUG, LIQUID TIGHT, 1/2 CONDUIT
13	1	28731162	RECEPTACLE, FEM, M12, 5 POLE
14	1	29133100	SWITCH, SELECTOR, MNTD-OFF-MOM
15	1	29133101	BASE, SWITCH, 2 NO CONTACTS
16	1	29142200	HEAD, PUSHBUTTON, LED, RED
17	1	29142201	BASE, SWITCH, 1 NO/ 1 NC, LED
18	1	67040074	DECAL, SWITCHES, PUMP
19	1	67040075	DECAL, CONNECTIONS, PUMP
20	1	85595500	ENCLOSURE, FIBERGLASS, 12X10X6
21	1	85595501	PANEL, BACK, ELECTRICAL, VFD
22	2	85595502	RAIL, DIN, 35 MM X 4.5
23	1	85595519	BREAKER, CIRCUIT, MOTOR, 3-POL, 1-1.6A
24	1	85595564	DRIVE, AC, 3-PH, 525-600 VAC, 1-HP
25	1	85595565	BREAKER, CIRCUIT, MOTOR, 3-POL, 1.6-2.5A
26	1	85595566	POWER SUPPLY, 600VAC, 24V, 120W, 5A

NOTE: 1. WIRES AND ENCLOSURE LID REMOVED FOR CLARITY.
 2. LOAD PROGRAM PRG5507 I.A.W. EN5512 USING MULTILoader BEFORE SHIPMENT.

PL559592	REV A
----------	-------

SECTION VI

MAINTENANCE (continued)

67.0 ELECTRICAL ENCLOSURE, 1-PHASE 100-120VAC, PENDANT CONTROL, 5-6 VALVES

NO	QTY	PART NO	DESCRIPTION
N/A	N/A	95595607	AY, ENCL, 1HP, IP, 100-120V, XV
1	7	21411025	SCREW, #8-32 UNC-2AX.5, SELF-TAPPING
2	1	27511200	CABLE, POWER, 12-3, 8 FT
3	1	27642300	RECEPTACLE, FEM, M8, 4 POLE
4	2	28512400	RELIEF, STRAIN, CORD, 1/2 NPT
5	2	28542000	NUT, LOCK, 1/2 NPT
6	1	28615600	STRAIN RELIEF, CABLE, M25
7	1	28625600	STRAIN RELIEF, 90°, HINGED, M25
8	2	28645000	NUT, LOCK, NYLON, M25
9	1	28731124	BLOCK, WAGO, 2 WIRE
10	1	28731126	BLOCK, WAGO, 4 WIRE
11	2	28731128	BLOCK, END, 35MM RAIL
12	1	28731146	END PLATE, WAGO TERMINAL BLOCK
13	1	28731162	RECEPTACLE, FEM, M12, 5 POLE
14	1	28731166	BLOCK, TERM, 3 LEVEL, THRU/THRU/THRU
15	1	28731168	COVER, END, TERM, 3 LEVEL
16	1	29133100	SWITCH, SELECTOR, MNTD-OFF-MOM
17	1	29133101	BASE, SWITCH, 2 NO CONTACTS
18	1	29142200	HEAD, PUSHBUTTON, LED, RED
19	1	29142201	BASE, SWITCH, 1 NO/ 1 NC, LED
20	1	67040074	DECAL, SWITCHES, PUMP
21	1	67040075	DECAL, CONNECTIONS, PUMP
22	1	85595500	ENCLOSURE, FIBERGLASS, 12X10X6
23	1	85595501	PANEL, BACK, ELECTRICAL, VFD
24	2	85595502	RAIL, DIN, 35 MM X 4.5
25	1	85595503	BLOCK, DISTRIBUTION, 1/4
26	1	85595505	POWER SUPPLY, 24V, 240W
27	1	85595507	DRIVE, AC, 1-PH, 100-120 VAC, 1-HP
28	1	85595508	BREAKER, CIRCUIT, 1 POL, 240V, 20A
29	1	85595545	BREAKER, CIRCUIT, 1 POL, 240V, 6A

NOTE: 1. WIRES AND ENCLOSURE LID REMOVED FOR CLARITY.
 2. LOAD PROGRAM PRG5500 I.A.W. EN5512 USING MULTILOADER BEFORE SHIPMENT.

PL559545	REV B
----------	-------

SECTION VI

MAINTENANCE (continued)

68.0 ELECTRICAL ENCLOSURE, 3-PHASE 200-240VAC, PENDANT CONTROL, 5-6 VALVES

NO	QTY	PART NO	DESCRIPTION
N/A	N/A	95595613	AY, ENCL, 1HP, 3P, 200-240V, XV
1	7	21411025	SCREW, #8-32 UNC-2AX.5, SELF-TAPPING
2	1	27642300	RECEPTACLE, FEM, M8, 4 POLE
3	2	28512400	RELIEF, STRAIN, CORD, 1/2 NPT
4	2	28542000	NUT, LOCK, 1/2 NPT
5	1	28615600	STRAIN RELIEF, CABLE, M25
6	1	28625600	STRAIN RELIEF, 90°, HINGED, M25
7	2	28645000	NUT, LOCK, NYLON, M25
8	1	28731124	BLOCK, WAGO, 2 WIRE
9	1	28731126	BLOCK, WAGO, 4 WIRE
10	2	28731128	BLOCK, END, 35MM RAIL
11	1	28731146	END PLATE, WAGO TERMINAL BLOCK
12	1	28731162	RECEPTACLE, FEM, M12, 5 POLE
13	1	28731166	BLOCK, TERM, 3 LEVEL, THRU/THRU/THRU
14	1	28731168	COVER, END, TERM, 3 LEVEL
15	1	29133100	SWITCH, SELECTOR, MNTD-OFF-MOM
16	1	29133101	BASE, SWITCH, 2 NO CONTACTS
17	1	29142200	HEAD, PUSHBUTTON, LED, RED
18	1	29142201	BASE, SWITCH, 1 NO/ 1 NC, LED
19	1	67040074	DECAL, SWITCHES, PUMP
20	1	67040075	DECAL, CONNECTIONS, PUMP
21	1	85595500	ENCLOSURE, FIBERGLASS, 12X10X6
22	1	85595501	PANEL, BACK, ELECTRICAL, VFD
23	2	85595502	RAIL, DIN, 35 MM X 4.5
24	1	85595505	POWER SUPPLY, 24V, 240W
25	1	85595515	DRIVE, AC, 3-PH, 200-240 VAC, 1-HP
26	1	85595516	BREAKER, CIRCUIT, 3 POL, 240V, 7A
27	1	85595547	BREAKER, CIRCUIT, 2 POLE, 240V, 4A

NOTE: 1. WIRES AND ENCLOSURE LID REMOVED FOR CLARITY.
 2. LOAD PROGRAM PRG5502 I.A.W. EN5512 USING MULTILoader BEFORE SHIPMENT.

SEE NOTE 2

PL559547	REV B
----------	-------

SECTION VI

MAINTENANCE (continued)

69.0 ELECTRICAL ENCLOSURE, 3-PHASE 380-500VAC, PENDANT CONTROL, 5-6 VALVES

NO	QTY	PART NO	DESCRIPTION
N/A	N/A	95595615	AY, ENCL, 1HP, 3P, 380-500V, XV
1	7	21411025	SCREW, #8-32 UNC-2AX.5, SELF-TAPPING
2	1	27642300	RECEPTACLE, FEM, M8, 4 POLE
3	2	28512400	RELIEF, STRAIN, CORD, 1/2 NPT
4	2	28542000	NUT, LOCK, 1/2 NPT
5	1	28615600	STRAIN RELIEF, CABLE, M25
6	1	28625600	STRAIN RELIEF, 90°, HINGED, M25
7	2	28645000	NUT, LOCK, NYLON, M25
8	1	28731124	BLOCK, WAGO, 2 WIRE
9	1	28731126	BLOCK, WAGO, 4 WIRE
10	2	28731128	BLOCK, END, 35MM RAIL
11	1	28731146	END PLATE, WAGO TERMINAL BLOCK
12	1	28731162	RECEPTACLE, FEM, M12, 5 POLE
13	1	28731166	BLOCK, TERM, 3 LEVEL, THRU/THRU/THRU
14	1	28731168	COVER, END, TERM, 3 LEVEL
15	1	29133100	SWITCH, SELECTOR, MNTD-OFF-MOM
16	1	29133101	BASE, SWITCH, 2 NO CONTACTS
17	1	29142200	HEAD, PUSHBUTTON, LED, RED
18	1	29142201	BASE, SWITCH, 1 NO/ 1 NC, LED
19	1	67040074	DECAL, SWITCHES, PUMP
20	1	67040075	DECAL, CONNECTIONS, PUMP
21	1	85595500	ENCLOSURE, FIBERGLASS, 12X10X6
22	1	85595501	PANEL, BACK, ELECTRICAL, VFD
23	2	85595502	RAIL, DIN, 35 MM X 4.5
24	1	85595505	POWER SUPPLY, 24V, 240W
25	1	85595548	BREAKER, CIRCUIT, MOTOR, 3-POL, 1.6-2.5A
26	1	85595549	DRIVE, AC, 3-PH, 380-500 VAC, 2-HP
27	1	85595550	BREAKER, CIRCUIT, MOTOR, 3-POL, 10A

NOTE: 1. WIRES AND ENCLOSURE LID REMOVED FOR CLARITY.
 2. LOAD PROGRAM PRG5504 I.A.W. EN5512 USING MULTILoader BEFORE SHIPMENT.

SEE NOTE 2

PL559548	REV C
----------	-------

SECTION VI

MAINTENANCE (continued)

70.0 ELECTRICAL ENCLOSURE, 3-PHASE 525-600VAC, PENDANT CONTROL, 5-6 VALVES

NO	QTY	PART NO	DESCRIPTION
N/A	N/A	95595634	AY, ENCL, 1HP, 3P, 525-600V, XV
1	7	21411025	SCREW, #8-32 UNC-2AX.5, SELF-TAPPING
2	1	27642300	RECEPTACLE, FEM, M8, 4 POLE
3	2	28512400	RELIEF, STRAIN, CORD, 1/2 NPT
4	2	28542000	NUT, LOCK, 1/2 NPT
5	1	28615600	STRAIN RELIEF, CABLE, M25
6	1	28625600	STRAIN RELIEF, 90°, HINGED, M25
7	2	28645000	NUT, LOCK, NYLON, M25
8	1	28731124	BLOCK, WAGO, 2 WIRE
9	1	28731126	BLOCK, WAGO, 4 WIRE
10	2	28731128	BLOCK, END, 35MM RAIL
11	1	28731146	END PLATE, WAGO TERMINAL BLOCK
12	1	28731162	RECEPTACLE, FEM, M12, 5 POLE
13	1	28731166	BLOCK, TERM, 3 LEVEL, THRU/THRU/THRU
14	1	28731168	COVER, END, TERM, 3 LEVEL
15	1	29133100	SWITCH, SELECTOR, MNTD-OFF-MOM
16	1	29133101	BASE, SWITCH, 2 NO CONTACTS
17	1	29142200	HEAD, PUSHBUTTON, LED, RED
18	1	29142201	BASE, SWITCH, 1 NO/ 1 NC, LED
19	1	67040074	DECAL, SWITCHES, PUMP
20	1	67040075	DECAL, CONNECTIONS, PUMP
21	1	85595500	ENCLOSURE, FIBERGLASS, 12X10X6
22	1	85595501	PANEL, BACK, ELECTRICAL, VFD
23	2	85595502	RAIL, DIN, 35 MM X 4.5
24	1	85595548	BREAKER, CIRCUIT, MOTOR, 3-POL, 1.6-2.5A
25	1	85595564	DRIVE, AC, 3-PH, 525-600 VAC, 1-HP
26	1	85595565	BREAKER, CIRCUIT, MOTOR, 3-POL, 1.6-2.5A
27	1	85595567	POWER SUPPLY, 600VAC, 24V, 240W, 10A

NOTE: 1. WIRES AND ENCLOSURE LID REMOVED FOR CLARITY.
 2. LOAD PROGRAM PRG5507 I.A.W. EN5512 USING MULTILoader BEFORE SHIPMENT.

SEE NOTE 2

PL559593	REV A
----------	-------

SECTION VI

MAINTENANCE (continued)

71.0 ELECTRICAL ENCLOSURE, 1-PHASE 100-120VAC, MACHINE INTERFACE CONTROL

NO	QTY	PART NO	DESCRIPTION
N/A	N/A	95595528	AY, ENCL, 1HP, IP, 100-120V, MC
1	7	21411025	SCREW, #8-32 UNC-2AX.5, SELF-TAPPING
2	1	27511200	CABLE, POWER, 12-3, 8 FT
3	1	27642300	RECEPTACLE, FEM, M8, 4 POLE
4	2	28512400	RELIEF, STRAIN, CORD, 1/2 NPT
5	2	28542000	NUT, LOCK, 1/2 NPT
6	1	28615600	STRAIN RELIEF, CABLE, M25
7	1	28625600	STRAIN RELIEF, 90°, HINGED, M25
8	2	28645000	NUT, LOCK, NYLON, M25
9	2	28731128	BLOCK, END, 35MM RAIL
10	1	28731162	RECEPTACLE, FEM, M12, 5 POLE
11	1	28731165	BLOCK, TERM, 3 LEVEL, THRU/THRU/GND
12	1	28731167	BLOCK, TERM, 3 LEVEL, ALL CONNECTED
13	1	28731168	COVER, END, TERM, 3 LEVEL
14	1	29133100	SWITCH, SELECTOR, MNTD-OFF-MOM
15	1	29133101	BASE, SWITCH, 2 NO CONTACTS
16	1	29142200	HEAD, PUSHBUTTON, LED, RED
17	1	29142201	BASE, SWITCH, 1 NO/ 1 NC, LED
18	2	29411103	RELAY, INTERFACE, SPDT, 6MM
19	3	29411104	RELAY, INTERFACE, DPDT, 14MM
20	1	67040074	DECAL, SWITCHES, PUMP
21	1	67040075	DECAL, CONNECTIONS, PUMP
22	1	85595500	ENCLOSURE, FIBERGLASS, 12X10X6
23	1	85595501	PANEL, BACK, ELECTRICAL, VFD
24	2	85595502	RAIL, DIN, 35 MM X 4.5
25	1	85595503	BLOCK, DISTRIBUTION, 1/4
26	1	85595507	DRIVE, AC, 1-PH, 100-120 VAC, 1-HP
27	1	85595508	BREAKER, CIRCUIT, 1 POL, 240V, 20A
28	1	85595509	BREAKER, CIRCUIT, 1 POL, 240V, 3A
29	1	85595525	POWER SUPPLY, 24V, 72W

NOTE: 1. WIRES AND ENCLOSURE LID REMOVED FOR CLARITY.
 2. LOAD PROGRAM PRG5500 I.A.W. EN5512 USING MULTILOADER BEFORE SHIPMENT.

RETAINING NUT INCLUDED

RETAINING NUT INCLUDED

SEE NOTE 2

RETAINING NUT INCLUDED

PL559549	REV B
----------	-------

SECTION VI

MAINTENANCE (continued)

72.0 ELECTRICAL ENCLOSURE, 3-PHASE 200-240VAC, MACHINE INTERFACE CONTROL

NO	QTY	PART NO	DESCRIPTION
N/A	N/A	95595534	AY, ENCL, IHP, 3P, 200-240V, MC
1	7	21411025	SCREW, #8-32 UNC-2AX.5, SELF-TAPPING
2	1	27642300	RECEPTACLE, FEM, M8, 4 POLE
3	2	28512400	RELIEF, STRAIN, CORD, 1/2 NPT
4	2	28542000	NUT, LOCK, 1/2 NPT
5	1	28615600	STRAIN RELIEF, CABLE, M25
6	1	28625600	STRAIN RELIEF, 90°, HINGED, M25
7	2	28645000	NUT, LOCK, NYLON, M25
8	2	28731128	BLOCK, END, 35MM RAIL
9	1	28731162	RECEPTACLE, FEM, M12, 5 POLE
10	1	28731165	BLOCK, TERM, 3 LEVEL, THRU/THRU/GND
11	1	28731167	BLOCK, TERM, 3 LEVEL, ALL CONNECTED
12	1	28731168	COVER, END, TERM, 3 LEVEL
13	1	29133100	SWITCH, SELECTOR, MNTD-OFF-MOM
14	1	29133101	BASE, SWITCH, 2 NO CONTACTS
15	1	29142200	HEAD, PUSHBUTTON, LED, RED
16	1	29142201	BASE, SWITCH, 1 NO/ 1 NC, LED
17	2	29411103	RELAY, INTERFACE, SPDT, 6MM
18	3	29411104	RELAY, INTERFACE, DPDT, 14MM
19	1	67040074	DECAL, SWITCHES, PUMP
20	1	67040075	DECAL, CONNECTIONS, PUMP
21	1	85595500	ENCLOSURE, FIBERGLASS, 12X10X6
22	1	85595501	PANEL, BACK, ELECTRICAL, VFD
23	2	85595502	RAIL, DIN, 35 MM X 4.5
24	1	85595513	BREAKER, CIRCUIT, 2 POLE, 240V, 2A
25	1	85595515	DRIVE, AC, 3-PH, 200-240 VAC, 1-HP
26	1	85595516	BREAKER, CIRCUIT, 3 POL, 240V, 7A
27	1	85595525	POWER SUPPLY, 24V, 72W

NOTE: 1. WIRES AND ENCLOSURE LID REMOVED FOR CLARITY.
 2. LOAD PROGRAM PRG5502 I.A.W. EN5512 USING MULTILOADER BEFORE SHIPMENT.

RETAINING NUT INCLUDED

RETAINING NUT INCLUDED

SEE NOTE 2

PL559551	REV B
----------	-------

SECTION VI

MAINTENANCE (continued)

73.0 ELECTRICAL ENCLOSURE, 3-PHASE 380-500VAC, MACHINE INTERFACE CONTROL

NO	QTY	PART NO	DESCRIPTION
N/A	N/A	95595536	AY, ENCL, 1HP, 3P, 380-500V, MC
1	7	21411025	SCREW, #8-32 UNC-2AX.5, SELF-TAPPING
2	1	27642300	RECEPTACLE, FEM, M8, 4 POLE
3	2	28512400	RELIEF, STRAIN, CORD, 1/2 NPT
4	2	28542000	NUT, LOCK, 1/2 NPT
5	1	28615600	STRAIN RELIEF, CABLE, M25
6	1	28625600	STRAIN RELIEF, 90°, HINGED, M25
7	2	28645000	NUT, LOCK, NYLON, M25
8	2	28731128	BLOCK, END, 35MM RAIL
9	1	28731162	RECEPTACLE, FEM, M12, 5 POLE
10	1	28731165	BLOCK, TERM, 3 LEVEL, THRU/THRU/GND
11	1	28731167	BLOCK, TERM, 3 LEVEL, ALL CONNECTED
12	1	28731168	COVER, END, TERM, 3 LEVEL
13	1	29133100	SWITCH, SELECTOR, MNTD-OFF-MOM
14	1	29133101	BASE, SWITCH, 2 NO CONTACTS
15	1	29142200	HEAD, PUSHBUTTON, LED, RED
16	1	29142201	BASE, SWITCH, 1 NO/ 1 NC, LED
17	2	29411103	RELAY, INTERFACE, SPDT, 6MM
18	3	29411104	RELAY, INTERFACE, DPDT, 14MM
19	1	67040074	DECAL, SWITCHES, PUMP
20	1	67040075	DECAL, CONNECTIONS, PUMP
21	1	85595500	ENCLOSURE, FIBERGLASS, 12X10X6
22	1	85595501	PANEL, BACK, ELECTRICAL, VFD
23	2	85595502	RAIL, DIN, 35 MM X 4.5
24	1	85595519	BREAKER, CIRCUIT, MOTOR, 3-POL, 1-1.6A
25	1	85595525	POWER SUPPLY, 24V, 72W
26	1	85595549	DRIVE, AC, 3-PH, 380-500 VAC, 2-HP
27	1	85595550	BREAKER, CIRCUIT, MOTOR, 3-POL, 10A

NOTE: 1. WIRES AND ENCLOSURE LID REMOVED FOR CLARITY.
2. LOAD PROGRAM PRG5504 I.A.W. EN5512 USING MULTILOADER BEFORE SHIPMENT.

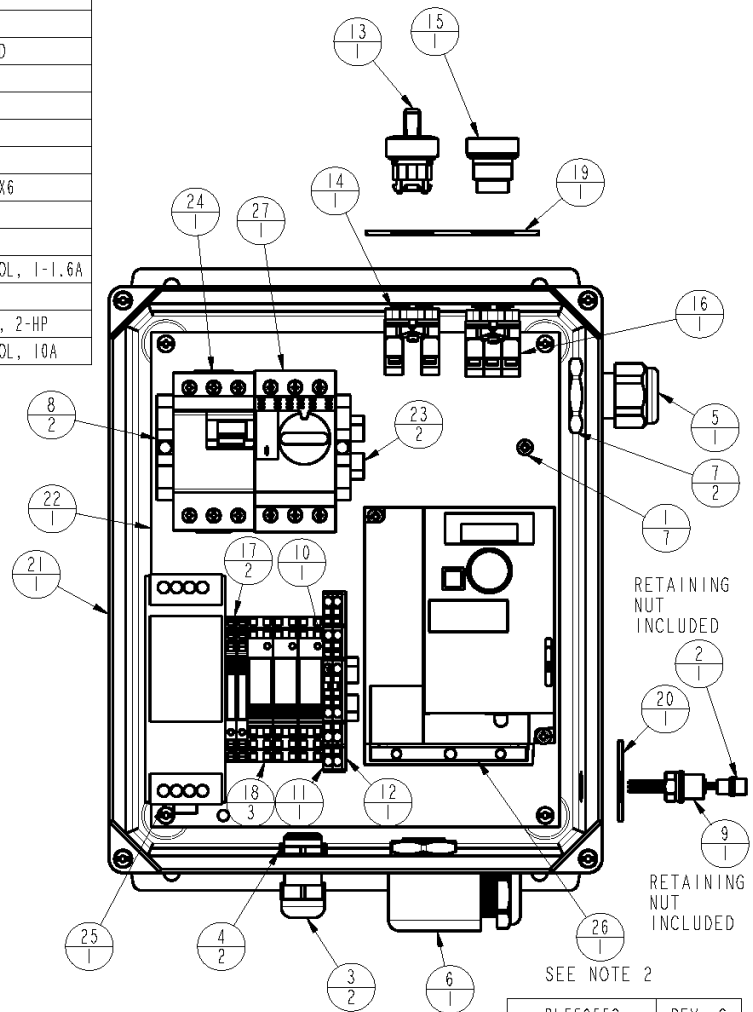

SECTION VI

MAINTENANCE (continued)

74.0 ELECTRICAL ENCLOSURE, 3-PHASE 525-600VAC, MACHINE INTERFACE CONTROL

NO	QTY	PART NO	DESCRIPTION
N/A	N/A	95595636	AY, ENCL, 1HP, 3P, 525-600V, MC
1	7	21411025	SCREW, #8-32 UNC-2AX.5, SELF-TAPPING
2	1	27642300	RECEPTACLE, FEM, M8, 4 POLE
3	2	28512400	RELIEF, STRAIN, CORD, 1/2 NPT
4	2	28542000	NUT, LOCK, 1/2 NPT
5	1	28615600	STRAIN RELIEF, CABLE, M25
6	1	28625600	STRAIN RELIEF, 90°, HINGED, M25
7	2	28645000	NUT, LOCK, NYLON, M25
8	2	28731128	BLOCK, END, 35MM RAIL
9	1	28731162	RECEPTACLE, FEM, M12, 5 POLE
10	1	28731165	BLOCK, TERM, 3 LEVEL, THRU/THRU/GND
11	1	28731167	BLOCK, TERM, 3 LEVEL, ALL CONNECTED
12	1	28731168	COVER, END, TERM, 3 LEVEL
13	1	29133100	SWITCH, SELECTOR, MNTD-OFF-MOM
14	1	29133101	BASE, SWITCH, 2 NO CONTACTS
15	1	29142200	HEAD, PUSHBUTTON, LED, RED
16	1	29142201	BASE, SWITCH, 1 NO/ 1 NC, LED
17	2	29411103	RELAY, INTERFACE, SPDT, 6MM
18	3	29411104	RELAY, INTERFACE, DPDT, 14MM
19	1	67040074	DECAL, SWITCHES, PUMP
20	1	67040075	DECAL, CONNECTIONS, PUMP
21	1	85595500	ENCLOSURE, FIBERGLASS, 12X10X6
22	1	85595501	PANEL, BACK, ELECTRICAL, VFD
23	2	85595502	RAIL, DIN, 35 MM X 4.5
24	1	85595519	BREAKER, CIRCUIT, MOTOR, 3-POL, 1-1.6A
25	1	85595564	DRIVE, AC, 3-PH, 525-600 VAC, 1-HP
26	1	85595565	BREAKER, CIRCUIT, MOTOR, 3-POL, 1.6-2.5A
27	1	85595566	POWER SUPPLY, 600VAC, 24V, 120W, 5A

NOTE: 1. WIRES AND ENCLOSURE LID REMOVED FOR CLARITY.
 2. LOAD PROGRAM PRG5507 I.A.W. EN5512 USING MULTILOADER BEFORE SHIPMENT.

PL559594	REV A
----------	-------

SECTION VI

MAINTENANCE (continued)

75.0 ELECTRICAL ENCLOSURE, HYDRAULIC PUMP INTERFACE UNIT, 1-4 VALVE

NO	QTY	PART NO	DESCRIPTION
N/A	N/A	95595624	AY, ENCLOSURE, AWP, HPIU, 4 VLV
1	4	21410055	S.H.C.S. 8-32 UNC X .50 LG.
2	10	21411025	SCREW, #8-32 UNC-2AX.5, SELF-TAPPING
3	4	21420023	NUT, HEX, 8-32
4	2	28615600	STRAIN RELIEF, CABLE, M25
5	2	28645000	NUT, LOCK, NYLON, M25
6	1	28645002	NUT, LOCK, NYLON, M32
7	6	28731128	BLOCK, END, 35MM RAIL
8	4	28731167	BLOCK, TERM, 3 LEVEL, ALL CONNECTED
9	3	28731168	COVER, END, TERM, 3 LEVEL
10	1	28731169	PLUG, LIQUID TIGHT, 1" HOLE
11	22	29411103	RELAY, INTERFACE, SPDT, 6MM
12	1	67040094	LABEL, AWP, HPIU
13	2	85594002	RAIL, DIN, 35 MM x 8.88 IN.
14	1	85595504	POWER SUPPLY, 24V, 120W
15	1	85595528	STRAIN RELIEF, CABLE, M32
16	1	85595560	ENCLOSURE, AWP, HPIU
17	1	85595561	PANEL, BACK, 12X10, HPIU, MIU
18	1	85595562	CONTACTOR, 3P, 440VAC, 9A, 24VDC
19	1	95595627	AY, CONNECTOR, FEMALE, HPIU, 1-4 VLV

NOTE: 1. WIRES AND ENCLOSURE LID REMOVED FOR CLARITY.

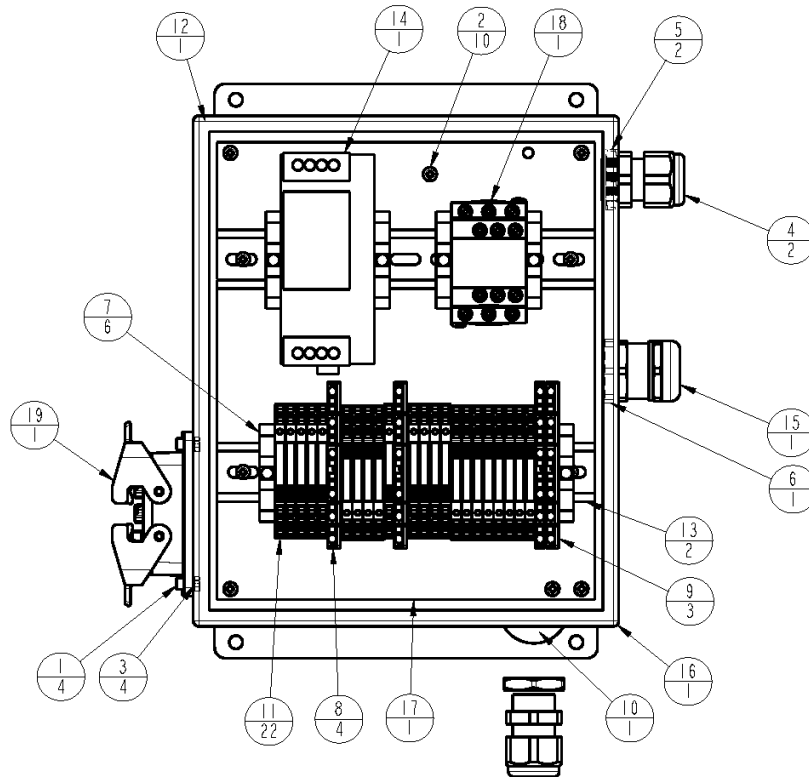

PL559587

REV A

SECTION VI

MAINTENANCE (continued)

76.0 ELECTRICAL ENCLOSURE, HYDRAULIC PUMP INTERFACE UNIT, 5-6 VALVE

NO	QTY	PART NO	DESCRIPTION	
N/A	N/A	95595626	AY, ENCLOSURE, AWP, HPIU, XV	NOTE: 1. WIRES AND ENCLOSURE LID REMOVED FOR CLARITY.
1	4	21410055	S.H.C.S. 8-32 UNC X .50 LG.	
2	6	21411025	SCREW, #8-32 UNC-2AX.5, SELF-TAPPING	
3	4	21420023	NUT, HEX, 8-32	
4	2	28615600	STRAIN RELIEF, CABLE, M25	
5	2	28645000	NUT, LOCK, NYLON, M25	
6	1	28645002	NUT, LOCK, NYLON, M32	
7	6	28731128	BLOCK, END, 35MM RAIL	
8	4	28731167	BLOCK, TERM, 3 LEVEL, ALL CONNECTED	
9	3	28731168	COVER, END, TERM, 3 LEVEL	
10	1	28731169	PLUG, LIQUID TIGHT, 1" HOLE	
11	30	29411103	RELAY, INTERFACE, SPDT, 6MM	
12	1	67040094	LABEL, AWP, HPIU	
13	2	85594002	RAIL, DIN, 35 MM x 8.88 IN.	
14	1	85595505	POWER SUPPLY, 24V, 240W	
15	1	85595528	STRAIN RELIEF, CABLE, M32	
16	1	85595560	ENCLOSURE, AWP, HPIU	
17	1	85595561	PANEL, BACK, 12X10, HPIU, MIU	
18	1	85595562	CONTACTOR, 3P, 440VAC, 9A, 24VDC	
19	1	95595628	AY, CONNECTOR, FEMALE, HPIU, XV	

PL559589	REV A
----------	-------

SECTION VI

MAINTENANCE (continued)

77.0 ELECTRICAL ENCLOSURE, 3-PHASE 200-240VAC, MACHINE INTERFACE CONTROL, ETHERNET

NO	QTY	PART NO	DESCRIPTION
N/A	N/A	95595638	AY, ENCL, 1HP, 3P, 200-240V, MCE
1	8	21411025	SCREW, #8-32 UNC-2AX.5, SELF-TAPPING
2	1	27642300	RECEPTACLE, FEM, M8, 4 POLE
3	1	27742207	CABLE, MALE RJ45 - MALE/RJ45, 4P, .3m
4	2	27742208	CABLE, FLNG, M12, D-CODE, FM, 4P/ML/RJ45 .3m
5	2	28512400	RELIEF, STRAIN, CORD, 1/2 NPT
6	2	28542000	NUT, LOCK, 1/2 NPT
7	1	28615600	STRAIN RELIEF, CABLE, M25
8	1	28625600	STRAIN RELIEF, 90°, HINGED, M25
9	2	28645000	NUT, LOCK, NYLON, M25
10	4	28731128	BLOCK, END, 35MM RAIL
11	2	28731162	RECEPTACLE, FEM, M12, 5 POLE
12	3	28731167	BLOCK, TERM, 3 LEVEL, ALL CONNECTED
13	1	28731168	COVER, END, TERM, 3 LEVEL
14	1	28731170	PLUG, LIQUID TIGHT, 5/8" HOLE
15	1	29133100	SWITCH, SELECTOR, MNTD-OFF-MOM
16	1	29133101	BASE, SWITCH, 2 NO CONTACTS
17	1	29142200	HEAD, PUSHBUTTON, LED, RED
18	1	29142201	BASE, SWITCH, 1 NO/ 1 NC, LED
19	1	29411103	RELAY, INTERFACE, SPDT, 6MM
20	1	29411110	RELAY, SOCKET, RSZ
21	1	29411111	RELAY, PLUG-IN, SPST, 24VDC, 12A
22	1	29411112	MODULE, RSZ, DIODE, LED, 24VDC
23	1	67040074	DECAL, SWITCHES, PUMP
24	1	67040075	DECAL, CONNECTIONS, PUMP
25	1	67040098	LABEL, CONNECTIONS, MCE
26	1	67040100	LABEL, DANGER, ARC FLASH, 3-1/2 X 5
27	1	85595505	POWER SUPPLY, 24V, 240W
28	1	85595512	BREAKER, CIRCUIT, 1 POL, 240V, 10A
29	1	85595514	BREAKER, CIRCUIT, 1 POL, 240V, 2A
30	1	85595515	DRIVE, AC, 3-PH, 200-240 VAC, 1-HP
31	1	85595547	BREAKER, CIRCUIT, 2 POLE, 240V, 4A
32	1	85595550	BREAKER, CIRCUIT, MOTOR, 3-POL, 6-10A
33	1	85595568	ENCLOSURE, ELECT, 14X12, MCE
34	1	85595569	PANEL, ENCLOSURE, 14X12, MCE
35	1	85595571	CONTROLLER, M241, 24 IO, TRANS, PNP
36	1	85595572	SWITCH, ETHERNET, RJ45, 4 PORT
37	1	85595575	RAIL, DIN, 35 MM X 7.00
38	1	85595576	RAIL, DIN, 35 MM X 11.12
39	1	85595577	CONTACT, STARTER, AUX, 1NO/1NC
40	1	85595578	SDHC CARD, 8GB MINIMUM

NOTES:

1. WIRES/CABLES OMITTED FOR CLARITY
2. LOAD PRG5509 I.A.W. EN5512 USING MULTILoader BEFORE SHIPMENT.
3. INSTALL BATTERY SUPPLIED WITH CONTROLLER IN BATTERY HOLDER PER CONTROLLER INSTRUCTIONS.
4. FORMAT SD CARD TO FAT OR FAT32, LOAD INSTALL SCRIPT, CONTROLLER PROGRAM PLC5500, PUMP MANUALS, AND INSTALL IN SD CARD SLOT PER CONTROLLER INSTRUCTIONS.

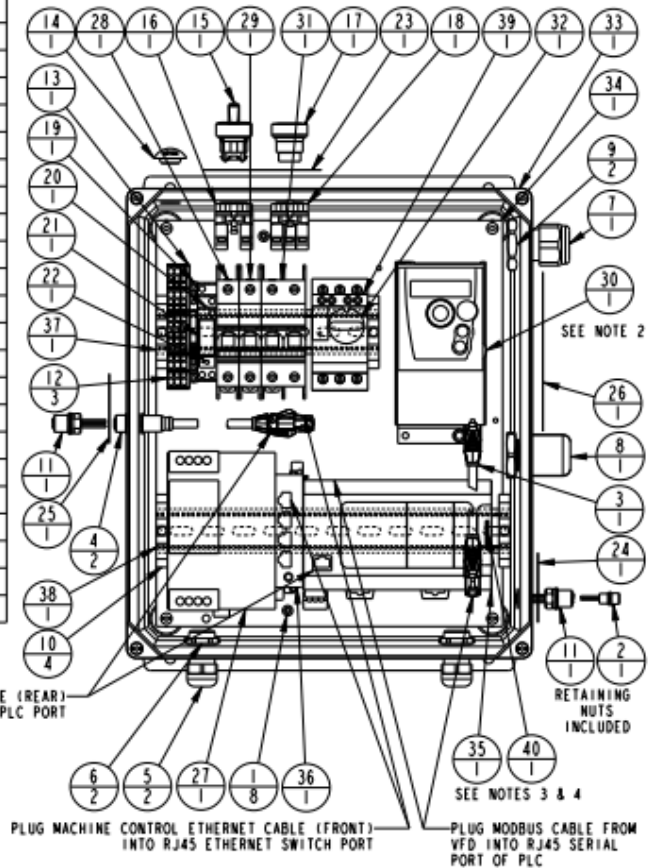

SECTION VI

MAINTENANCE (continued)

78.0 ELECTRICAL ENCLOSURE, 3-PHASE 380-500VAC, MACHINE INTERFACE CONTROL, ETHERNET

NO	QTY	PART NO	DESCRIPTION
N/A	N/A	95595640	AY, ENCL, 1HP, 3P, 380-500V, MCE
1	8	21411025	SCREW, #8-32 UNC-2AX.5, SELF-TAPPING
2	1	27642300	RECEPTACLE, FEM, M8, 4 POLE
3	1	27742207	CABLE, MALE RJ45 - MALE/RJ45, 4P, .3m
4	2	27742208	CABLE, FLNG, M12, D-CODE, FM, 4P/ML/RJ45 .3m
5	2	28512400	RELIEF, STRAIN, CORD, 1/2 NPT
6	2	28542000	NUT, LOCK, 1/2 NPT
7	1	28615600	STRAIN RELIEF, CABLE, M25
8	1	28625600	STRAIN RELIEF, 90°, HINGED, M25
9	2	28645000	NUT, LOCK, NYLON, M25
10	3	28731128	BLOCK, END, 35MM RAIL
11	2	28731162	RECEPTACLE, FEM, M12, 5 POLE
12	3	28731167	BLOCK, TERM, 3 LEVEL, ALL CONNECTED
13	1	28731168	COVER, END, TERM, 3 LEVEL
14	1	28731170	PLUG, LIQUID TIGHT, 5/8" HOLE
15	1	29133100	SWITCH, SELECTOR, MNTD-OFF-MOM
16	1	29133101	BASE, SWITCH, 2 NO CONTACTS
17	1	29142200	HEAD, PUSHBUTTON, LED, RED
18	1	29142201	BASE, SWITCH, 1 NO/ 1 NC, LED
19	1	29411103	RELAY, INTERFACE, SPDT, 6MM
20	1	29411110	RELAY, SOCKET, RSZ
21	1	29411111	RELAY, PLUG-IN, SPST, 24VDC, 12A
22	1	29411112	MODULE, RSZ, DIODE, LED, 24VDC
23	1	67040074	DECAL, SWITCHES, PUMP
24	1	67040075	DECAL, CONNECTIONS, PUMP
25	1	67040098	LABEL, CONNECTIONS, MCE
26	1	67040100	LABEL, DANGER, ARC FLASH, 3-1/2 X 5
27	1	85595505	POWER SUPPLY, 24V, 240W
28	1	85595512	BREAKER, CIRCUIT, 1 POL, 240V, 10A
29	1	85595514	BREAKER, CIRCUIT, 1 POL, 240V, 2A
30	1	85595548	BREAKER, CIRCUIT, MOTOR, 3-POL, 1.6-2.5A
31	1	85595549	DRIVE, AC, 3-PH, 380-500 VAC, 2-HP
32	1	85595550	BREAKER, CIRCUIT, MOTOR, 3-POL, 6-10A
33	1	85595568	ENCLOSURE, ELECT, 14X12, MCE
34	1	85595569	PANEL, ENCLOSURE, 14X12, MCE
35	1	85595571	CONTROLLER, M241, 24 IO, TRANS, PNP
36	1	85595572	SWITCH, ETHERNET, RJ45, 4 PORT
37	1	85595575	RAIL, DIN, 35 MM X 7.00
38	1	85595576	RAIL, DIN, 35 MM X 11.12
39	1	85595577	CONTACT, STARTER, AUX, 1NO/1NC
40	1	85595578	SDHC CARD, 8GB MINIMUM

NOTES:

1. WIRES/CABLES OMITTED FOR CLARITY
2. LOAD PRG5510 I.A.W. EN5512 USING MULTILOADER BEFORE SHIPMENT.
3. INSTALL BATTERY SUPPLIED WITH CONTROLLER IN BATTERY HOLDER PER CONTROLLER INSTRUCTIONS.
4. FORMAT SD CARD TO FAT OR FAT32, LOAD INSTALL SCRIPT, CONTROLLER PROGRAM PLC5500, PUMP MANUALS, AND INSTALL IN SD CARD SLOT PER CONTROLLER INSTRUCTIONS.

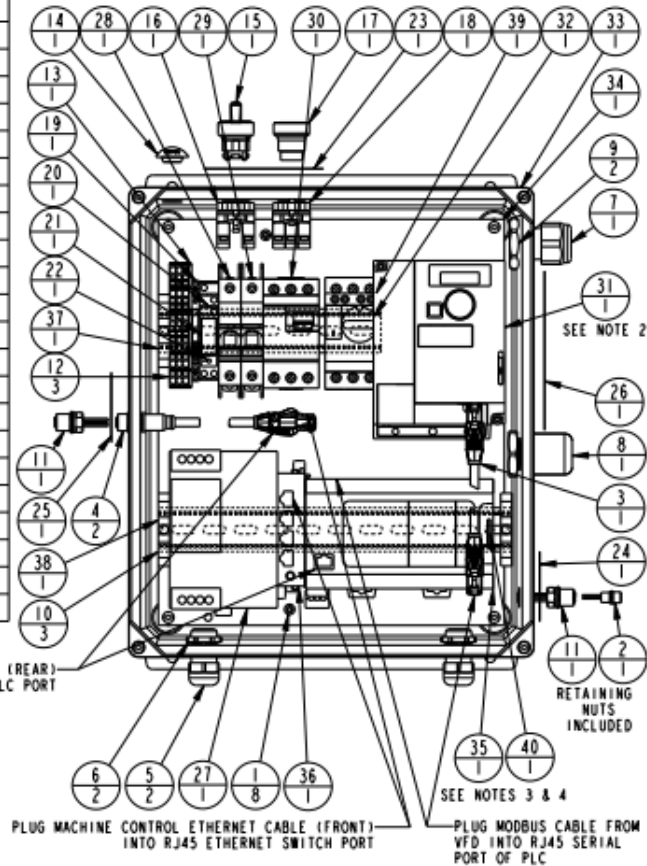

PL5595100 REV B

SECTION VI

MAINTENANCE (continued)

79.0 ELECTRICAL ENCLOSURE, 3-PHASE 525-600VAC, MACHINE INTERFACE CONTROL, ETHERNET

NO	QTY	PART NO	DESCRIPTION
N/A	N/A	95595642	AY, ENCL, 1HP, 3P, 525-600V, MCE
1	8	21411025	SCREW, #8-32 UNC-2AX.5, SELF-TAPPING
2	1	27642300	RECEPTACLE, FEM, N8, 4 POLE
3	1	27742207	CABLE, MALE RJ45 - MALE/RJ45, 4P, .3m
4	2	27742208	CABLE, FLNG, M12, D-CODE, FM, 4P/ML/RJ45 .3m
5	2	28512400	RELIEF, STRAIN, CORD, 1/2 NPT
6	2	28542000	NUT, LOCK, 1/2 NPT
7	1	28615600	STRAIN RELIEF, CABLE, M25
8	1	28625600	STRAIN RELIEF, 90°, HINGED, M25
9	2	28645000	NUT, LOCK, NYLON, M25
10	3	28731128	BLOCK, END, 35MM RAIL
11	2	28731162	RECEPTACLE, FEM, M12, 5 POLE
12	3	28731167	BLOCK, TERM, 3 LEVEL, ALL CONNECTED
13	1	28731168	COVER, END, TERM, 3 LEVEL
14	1	28731170	PLUG, LIQUID TIGHT, 5/8" HOLE
15	1	29133100	SWITCH, SELECTOR, MNTD-OFF-MOM
16	1	29133101	BASE, SWITCH, 2 NO CONTACTS
17	1	29142200	HEAD, PUSHBUTTON, LED, RED
18	1	29142201	BASE, SWITCH, 1 NO/ 1 NC, LED
19	1	29411103	RELAY, INTERFACE, SPDT, 6MM
20	1	29411110	RELAY, SOCKET, RSZ
21	1	29411111	RELAY, PLUG-IN, SPST, 24VDC, 12A
22	1	29411112	MODULE, RSZ, DIODE, LED, 24VDC
23	1	29411114	RELAY, CONTROL, VOLTAGE, 20-80V AC/DC
24	1	67040074	DECAL, SWITCHES, PUMP
25	1	67040075	DECAL, CONNECTIONS, PUMP
26	1	67040098	LABEL, CONNECTIONS, MCE
27	1	67040100	LABEL, DANGER, ARC FLASH, 3-1/2 X 5
28	1	85595512	BREAKER, CIRCUIT, 1 POL, 240V, 10A
29	1	85595514	BREAKER, CIRCUIT, 1 POL, 240V, 2A
30	1	85595548	BREAKER, CIRCUIT, MOTOR, 3-POL, 1.6-2.5A
31	1	85595564	DRIVE, AC, 3-PH, 525-600 VAC, 1-HP
32	1	85595565	BREAKER, CIRCUIT, MOTOR, 3-POL, 1.6-2.5A
33	1	85595567	POWER SUPPLY, 600VAC, 24V, 240W, 10A
34	1	85595568	ENCLOSURE, ELECT, 14X12, MCE
35	1	85595569	PANEL, ENCLOSURE, 14X12, MCE
36	1	85595571	CONTROLLER, M241, 24 IO, TRANS, PNP
37	1	85595572	SWITCH, ETHERNET, RJ45, 4 PORT
38	1	85595575	RAIL, DIN, 35 MM X 7.00
39	1	85595576	RAIL, DIN, 35 MM X 11.12
40	1	85595577	CONTACT, STARTER, AUX, 1NO/1NC
41	1	85595578	SDHC CARD, 8GB MINIMUM

NOTES:

1. WIRES/CABLES OMITTED FOR CLARITY
2. LOAD PRG5511 I.A.W. EN5512 USING MULTILOADER BEFORE SHIPMENT.
3. INSTALL BATTERY SUPPLIED WITH CONTROLLER IN BATTERY HOLDER PER CONTROLLER INSTRUCTIONS.
4. FORMAT SD CARD TO FAT OR FAT32, LOAD INSTALL SCRIPT, CONTROLLER PROGRAM PLC5500, PUMP MANUALS, AND INSTALL IN SD CARD SLOT PER CONTROLLER INSTRUCTIONS.

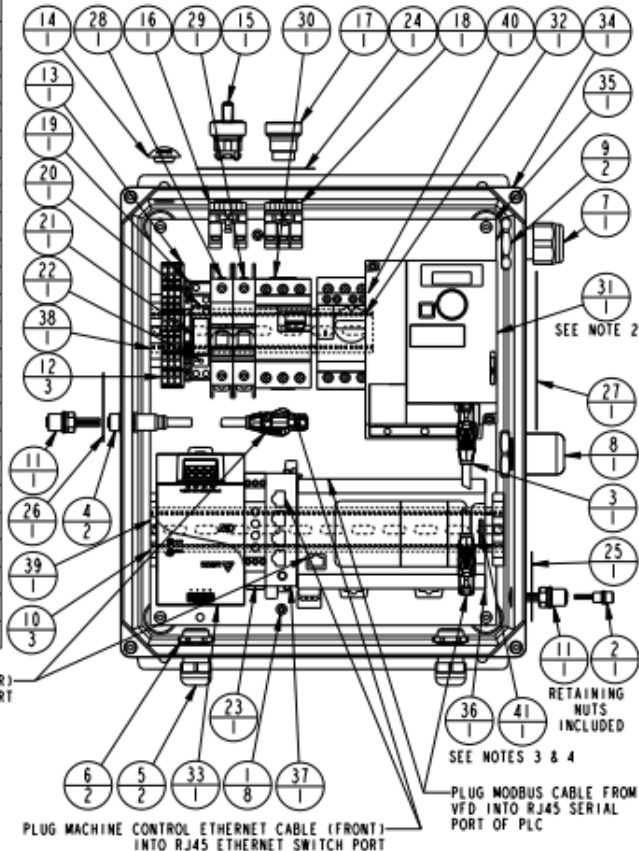

PL5595105 REV B

SECTION VI

MAINTENANCE (continued)

80.0 ELECTRICAL ENCLOSURE, 3-PHASE 200-240VAC, MACHINE INTERFACE CONTROL, HMI ETHERNET

NO	QTY	PART NO	DESCRIPTION
N/A	N/A	95595644	AY, ENCL, 1HP, 3P, 200-240V, HMI
1	8	21411025	SCREW, #8-32 UNC-2AX.5, SELF-TAPPING
2	1	27642300	RECEPTACLE, FEM, M8, 4 POLE
3	1	27742207	CABLE, MALE RJ45 - MALE/RJ45, 4P, .3m
4	2	27742208	CABLE, FLNG, M12, D-CODE, FM, 4P/ML/RJ45 .3m
5	2	28512400	RELIEF, STRAIN, CORD, 1/2 NPT
6	2	28542000	NUT, LOCK, 1/2 NPT
7	1	28615600	STRAIN RELIEF, CABLE, M25
8	1	28625600	STRAIN RELIEF, 90°, HINGED, M25
9	2	28645000	NUT, LOCK, NYLON, M25
10	4	28731128	BLOCK, END, 35MM RAIL
11	2	28731162	RECEPTACLE, FEM, M12, 5 POLE
12	3	28731167	BLOCK, TERM, 3 LEVEL, ALL CONNECTED
13	1	28731168	COVER, END, TERM, 3 LEVEL
14	1	28731171	CAP, PROTECTIVE, M12, FM, FLANGE
15	1	29133100	SWITCH, SELECTOR, MNTD-OFF-MOM
16	1	29133101	BASE, SWITCH, 2 NO CONTACTS
17	1	29142200	HEAD, PUSHBUTTON, LED, RED
18	1	29142201	BASE, SWITCH, 1 NO/ 1 NC, LED
19	1	29411103	RELAY, INTERFACE, SPDT, 6MM
20	1	29411110	RELAY, SOCKET, RSZ
21	1	29411111	RELAY, PLUG-IN, SPST, 24VDC, 12A
22	1	29411112	MODULE, RSZ, DIODE, LED, 24VDC
23	1	67040074	DECAL, SWITCHES, PUMP
24	1	67040075	DECAL, CONNECTIONS, PUMP
25	1	67040098	LABEL, CONNECTIONS, MCE
26	1	67040100	LABEL, DANGER, ARC FLASH, 3-1/2 X 5
27	1	67040103	LABEL, CONNECTIONS, HMI
28	1	85595505	POWER SUPPLY, 24V, 240W
29	1	85595512	BREAKER, CIRCUIT, 1 POL, 240V, 10A
30	1	85595514	BREAKER, CIRCUIT, 1 POL, 240V, 2A
31	1	85595515	DRIVE, AC, 3-PH, 200-240 VAC, 1-HP
32	1	85595547	BREAKER, CIRCUIT, 2 POLE, 240V, 4A
33	1	85595550	BREAKER, CIRCUIT, MOTOR, 3-POL, 6-10A
34	1	85595568	ENCLOSURE, ELECT, 14X12, MCE
35	1	85595569	PANEL, ENCLOSURE, 14X12, MCE
36	1	85595571	CONTROLLER, M241, 24 IO, TRANS, PNP
37	1	85595572	SWITCH, ETHERNET, RJ45, 4 PORT
38	1	85595575	RAIL, DIN, 35 MM X 7.00
39	1	85595576	RAIL, DIN, 35 MM X 11.12
40	1	85595577	CONTACT, STARTER, AUX, 1NO/1NC
41	1	85595578	SDHC CARD, 8GB MINIMUM
42	1	95595649	ASSY, CABLE, HYBRID, FEMALE, RJ45

NOTES:

1. WIRES/CABLES OMITTED FOR CLARITY
2. LOAD PRG5509 I.A.W. EN5512 USING MULTILOADER BEFORE SHIPMENT.
3. INSTALL BATTERY SUPPLIED WITH CONTROLLER IN BATTERY HOLDER PER CONTROLLER INSTRUCTIONS.
4. FORMAT SD CARD TO FAT OR FAT32, LOAD INSTALL SCRIPT, CONTROLLER PROGRAM PLC5501, PUMP MANUALS, AND INSTALL IN SD CARD SLOT PER CONTROLLER INSTRUCTIONS.

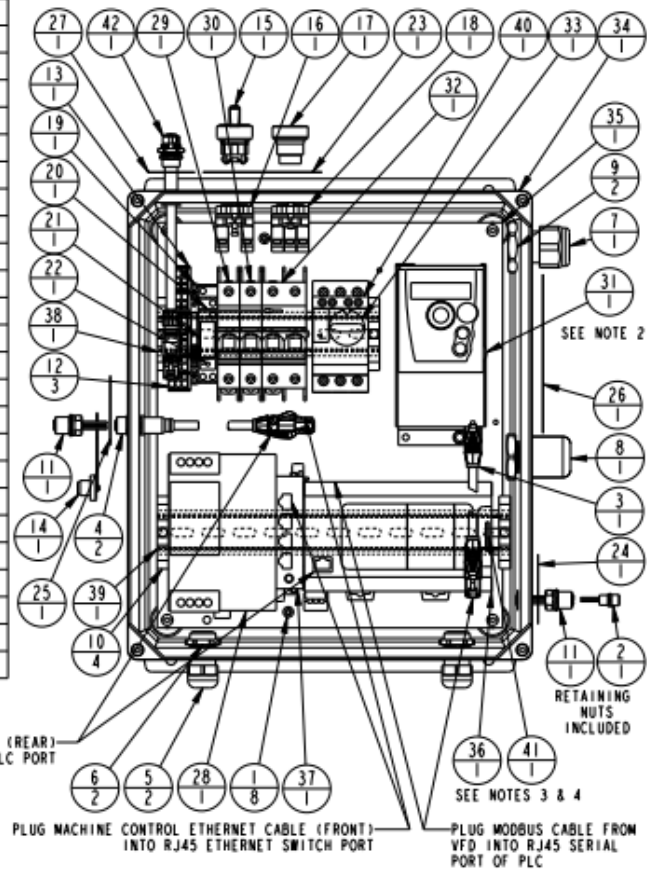

PL5595118 REVA

SECTION VI

MAINTENANCE (continued)

81.0 ELECTRICAL ENCLOSURE, 3-PHASE 380-500VAC, MACHINE INTERFACE CONTROL, HMI ETHERNET

NO	QTY	PART NO	DESCRIPTION
N/A	N/A	95595646	AY, ENCL, 1HP, 3P, 380-500V, HMI
1	8	21411025	SCREW, #8-32 UNC-2AX.5, SELF-TAPPING
2	1	27642300	RECEPTACLE, FEM, M8, 4 POLE
3	1	27742207	CABLE, MALE RJ45 - MALE/RJ45, 4P, .3m
4	2	27742208	CABLE, FLNG, M12, D-CODE, FM, 4P/ML/RJ45 .3m
5	2	28512400	RELIEF, STRAIN, CORD, 1/2 NPT
6	2	28542000	NUT, LOCK, 1/2 NPT
7	1	28615600	STRAIN RELIEF, CABLE, M25
8	1	28625600	STRAIN RELIEF, 90°, HINGED, M25
9	2	28645000	NUT, LOCK, NYLON, M25
10	3	28731128	BLOCK, END, 35MM RAIL
11	2	28731162	RECEPTACLE, FEM, M12, 5 POLE
12	3	28731167	BLOCK, TERM, 3 LEVEL, ALL CONNECTED
13	1	28731168	COVER, END, TERM, 3 LEVEL
14	1	28731171	CAP, PROTECTIVE, M12, FM, FLANGE
15	1	29133100	SWITCH, SELECTOR, MNTD-OFF-MOM
16	1	29133101	BASE, SWITCH, 2 NO CONTACTS
17	1	29142200	HEAD, PUSHBUTTON, LED, RED
18	1	29142201	BASE, SWITCH, 1 NO/1 NC, LED
19	1	29411103	RELAY, INTERFACE, SPDT, 6MM
20	1	29411110	RELAY, SOCKET, RSZ
21	1	29411111	RELAY, PLUG-IN, SPST, 24VDC, 12A
22	1	29411112	MODULE, RSZ, DIODE, LED, 24VDC
23	1	67040074	DECAL, SWITCHES, PUMP
24	1	67040075	DECAL, CONNECTIONS, PUMP
25	1	67040098	LABEL, CONNECTIONS, MCE
26	1	67040100	LABEL, DANGER, ARC FLASH, 3-1/2 X 5
27	1	67040103	LABEL, CONNECTIONS, HMI
28	1	85595505	POWER SUPPLY, 24V, 240W
29	1	85595512	BREAKER, CIRCUIT, 1 POL, 240V, 10A
30	1	85595514	BREAKER, CIRCUIT, 1 POL, 240V, 2A
31	1	85595548	BREAKER, CIRCUIT, MOTOR, 3-POL, 1.6-2.5A
32	1	85595549	DRIVE, AC, 3-PH, 380-500 VAC, 2-HP
33	1	85595550	BREAKER, CIRCUIT, MOTOR, 3-POL, 6-10A
34	1	85595568	ENCLOSURE, ELECT, 14X12, MCE
35	1	85595569	PANEL, ENCLOSURE, 14X12, MCE
36	1	85595571	CONTROLLER, M241, 24 IO, TRANS, PNP
37	1	85595572	SWITCH, ETHERNET, RJ45, 4 PORT
38	1	85595575	RAIL, DIN, 35 MM X 7.00
39	1	85595576	RAIL, DIN, 35 MM X 11.12
40	1	85595577	CONTACT, STARTER, AUX, 1NO/1NC
41	1	85595578	SDHC CARD, 8GB MINIMUM
42	1	95595649	ASSY, CABLE, HYBRID, FEMALE, RJ45

NOTES:

1. WIRES/CABLES OMITTED FOR CLARITY
2. LOAD PRG5510 I.A.W. EN5512 USING MULTILOADER BEFORE SHIPMENT.
3. INSTALL BATTERY SUPPLIED WITH CONTROLLER IN BATTERY HOLDER PER CONTROLLER INSTRUCTIONS.
4. FORMAT SD CARD TO FAT OR FAT32, LOAD INSTALL SCRIPT, CONTROLLER PROGRAM PLC5501, PUMP MANUALS, AND INSTALL IN SD CARD SLOT PER CONTROLLER INSTRUCTIONS.

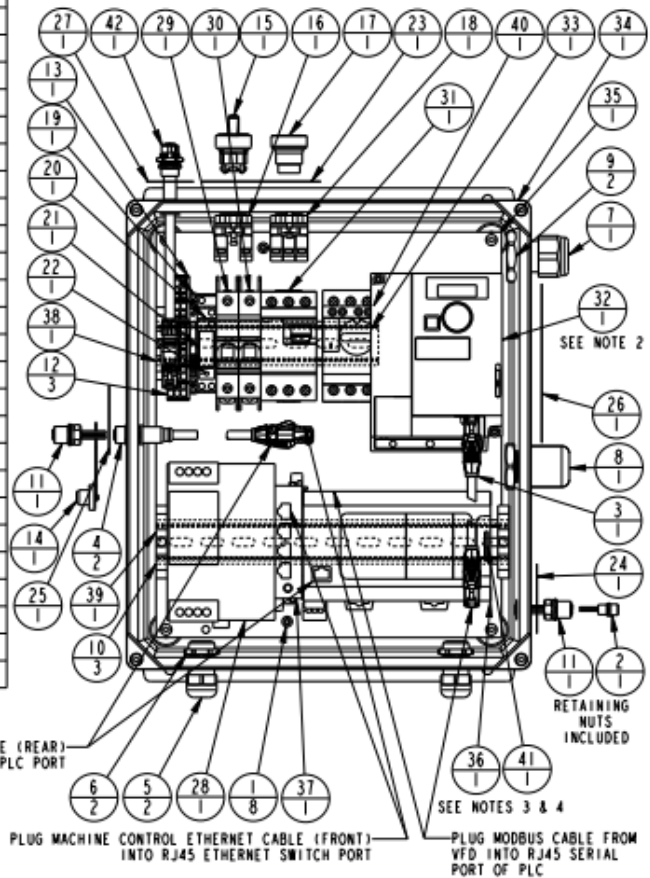

PLUG I/O MODULE ETHERNET CABLE (REAR) INTO FRONT RJ45 PLC PORT

PLUG MACHINE CONTROL ETHERNET CABLE (FRONT) INTO RJ45 ETHERNET SWITCH PORT

PLUG MODBUS CABLE FROM VFD INTO RJ45 SERIAL PORT OF PLC

PL5595115 REVA

SECTION VI

MAINTENANCE (continued)

82.0 ELECTRICAL ENCLOSURE, 3-PHASE 525-600VAC, MACHINE INTERFACE CONTROL, HMI ETHERNET

NO	QTY	PART NO	DESCRIPTION
N/A	N/A	95595648	AY, ENCL, 1HP, 3P, 525-600V, HMI
1	8	21411025	SCREW, #8-32 UNC-2AX.5, SELF-TAPPING
2	1	27642300	RECEPTACLE, FEM, M8, 4 POLE
3	1	27742207	CABLE, MALE RJ45 - MALE/RJ45, 4P, .3m
4	2	27742208	CABLE, FLNG, M12, D-CODE, FM, 4P/ML/RJ45 .3m
5	2	28512400	RELIEF, STRAIN, CORD, 1/2 NPT
6	2	28542000	NUT, LOCK, 1/2 NPT
7	1	28615600	STRAIN RELIEF, CABLE, M25
8	1	28625600	STRAIN RELIEF, 90°, HINGED, M25
9	2	28645000	NUT, LOCK, NYLON, M25
10	3	28731128	BLOCK, END, 35MM RAIL
11	2	28731162	RECEPTACLE, FEM, M12, 5 POLE
12	3	28731167	BLOCK, TERM, 3 LEVEL, ALL CONNECTED
13	1	28731168	COVER, END, TERM, 3 LEVEL
14	1	28731171	CAP, PROTECTIVE, M12, FM, FLANGE
15	1	29133100	SWITCH, SELECTOR, MNTD-OFF-MOM
16	1	29133101	BASE, SWITCH, 2 NO CONTACTS
17	1	29142200	HEAD, PUSHBUTTON, LED, RED
18	1	29142201	BASE, SWITCH, 1 NO/ 1 NC, LED
19	1	29411103	RELAY, INTERFACE, SPDT, 6MM
20	1	29411110	RELAY, SOCKET, RSZ
21	1	29411111	RELAY, PLUG-IN, SPST, 24VDC, 12A
22	1	29411112	MODULE, RSZ, DIODE, LED, 24VDC
23	1	29411114	RELAY, CONTROL, VOLTAGE, 20-80V AC/DC
24	1	67040074	DECAL, SWITCHES, PUMP
25	1	67040075	DECAL, CONNECTIONS, PUMP
26	1	67040098	LABEL, CONNECTIONS, MCE
27	1	67040100	LABEL, DANGER, ARC FLASH, 3-1/2 X 5
28	1	67040103	LABEL, CONNECTIONS, HMI
29	1	85595512	BREAKER, CIRCUIT, 1 POL, 240V, 10A
30	1	85595514	BREAKER, CIRCUIT, 1 POL, 240V, 2A
31	1	85595548	BREAKER, CIRCUIT, MOTOR, 3-POL, 1.6-2.5A
32	1	85595564	DRIVE, AC, 3-PH, 525-600 VAC, 1-HP
33	1	85595565	BREAKER, CIRCUIT, MOTOR, 3-POL, 1.6-2.5A
34	1	85595567	POWER SUPPLY, 600VAC, 24V, 240W, 10A
35	1	85595568	ENCLOSURE, ELECT, 14X12, MCE
36	1	85595569	PANEL, ENCLOSURE, 14X12, MCE
37	1	85595571	CONTROLLER, M241, 24 IO, TRANS, PNP
38	1	85595572	SWITCH, ETHERNET, RJ45, 4 PORT
39	1	85595575	RAIL, DIN, 35 MM X 7.00
40	1	85595576	RAIL, DIN, 35 MM X 11.12
41	1	85595577	CONTACT, STARTER, AUX, 1NO/1NC
42	1	85595578	SDHC CARD, 8GB MINIMUM
43	1	95595649	ASSY, CABLE, HYBRID, FEMALE, RJ45

NOTES:

1. WIRES/CABLES OMITTED FOR CLARITY
2. LOAD PRG5511 I.A.W. EN5512 USING MULTILOADER BEFORE SHIPMENT.
3. INSTALL BATTERY SUPPLIED WITH CONTROLLER IN BATTERY HOLDER PER CONTROLLER INSTRUCTIONS.
4. FORMAT SD CARD TO FAT OR FAT32, LOAD INSTALL SCRIPT, CONTROLLER PROGRAM PLC5501, PUMP MANUALS, AND INSTALL IN SD CARD SLOT PER CONTROLLER INSTRUCTIONS.

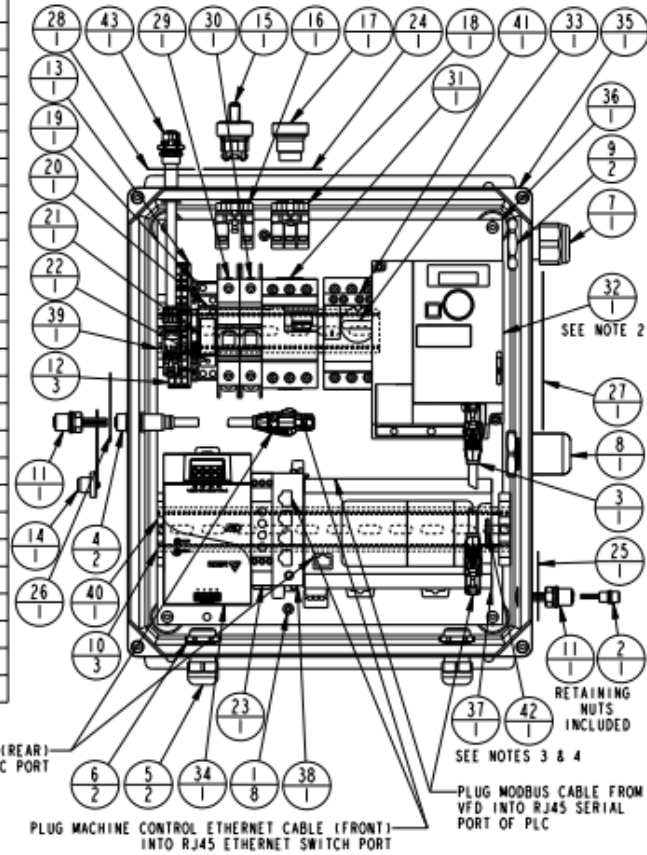

PL5595117 REVA

SECTION VI

MAINTENANCE (continued)

C. WIRING DIAGRAMS

1. Single Phase 100-120VAC No Valve or Pendant Controlled Valve Enclosure

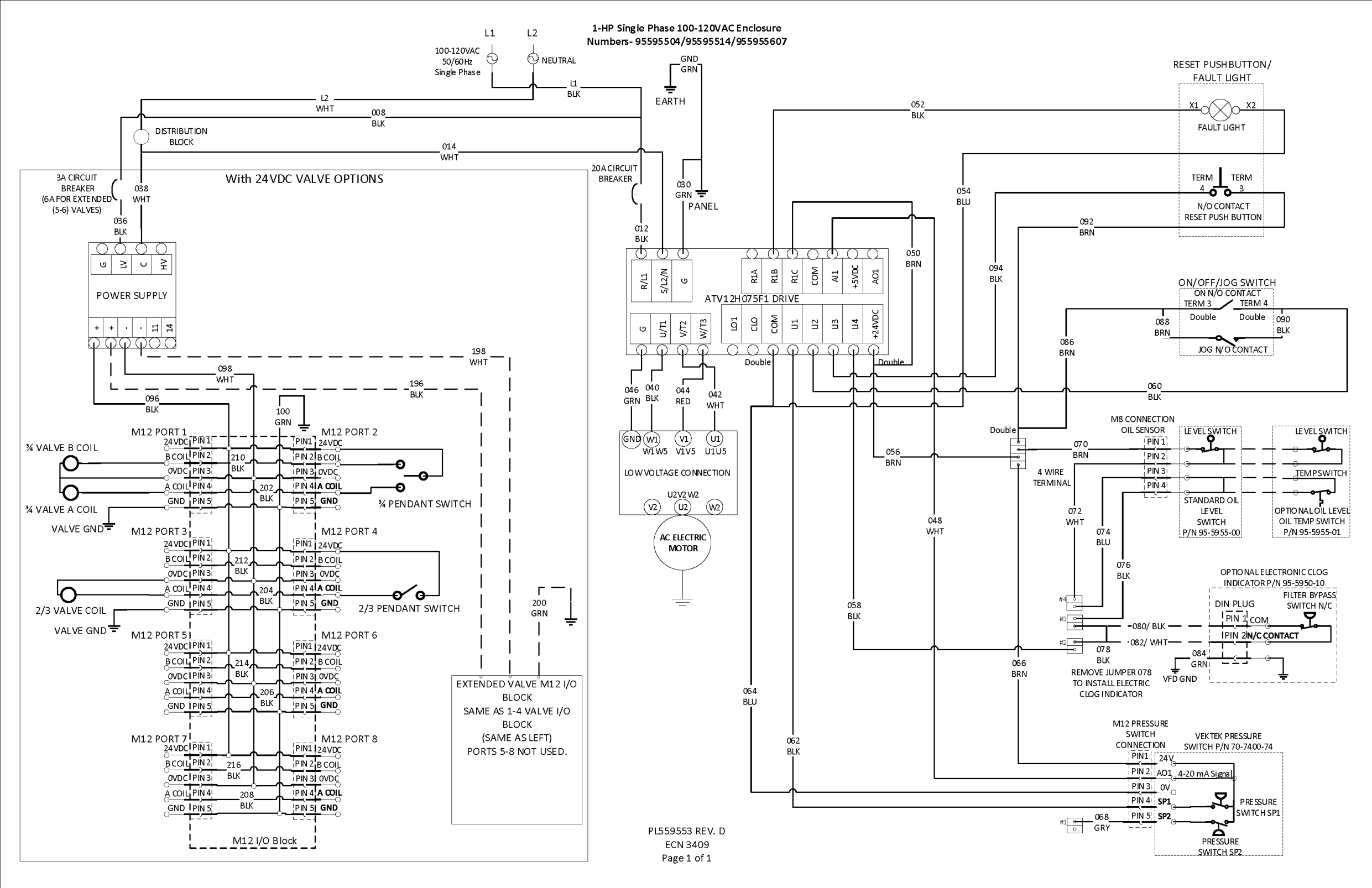

SECTION VI

MAINTENANCE (continued)

2. Three Phase 200-240VAC No Valve or Pendant Controlled Valve Enclosure

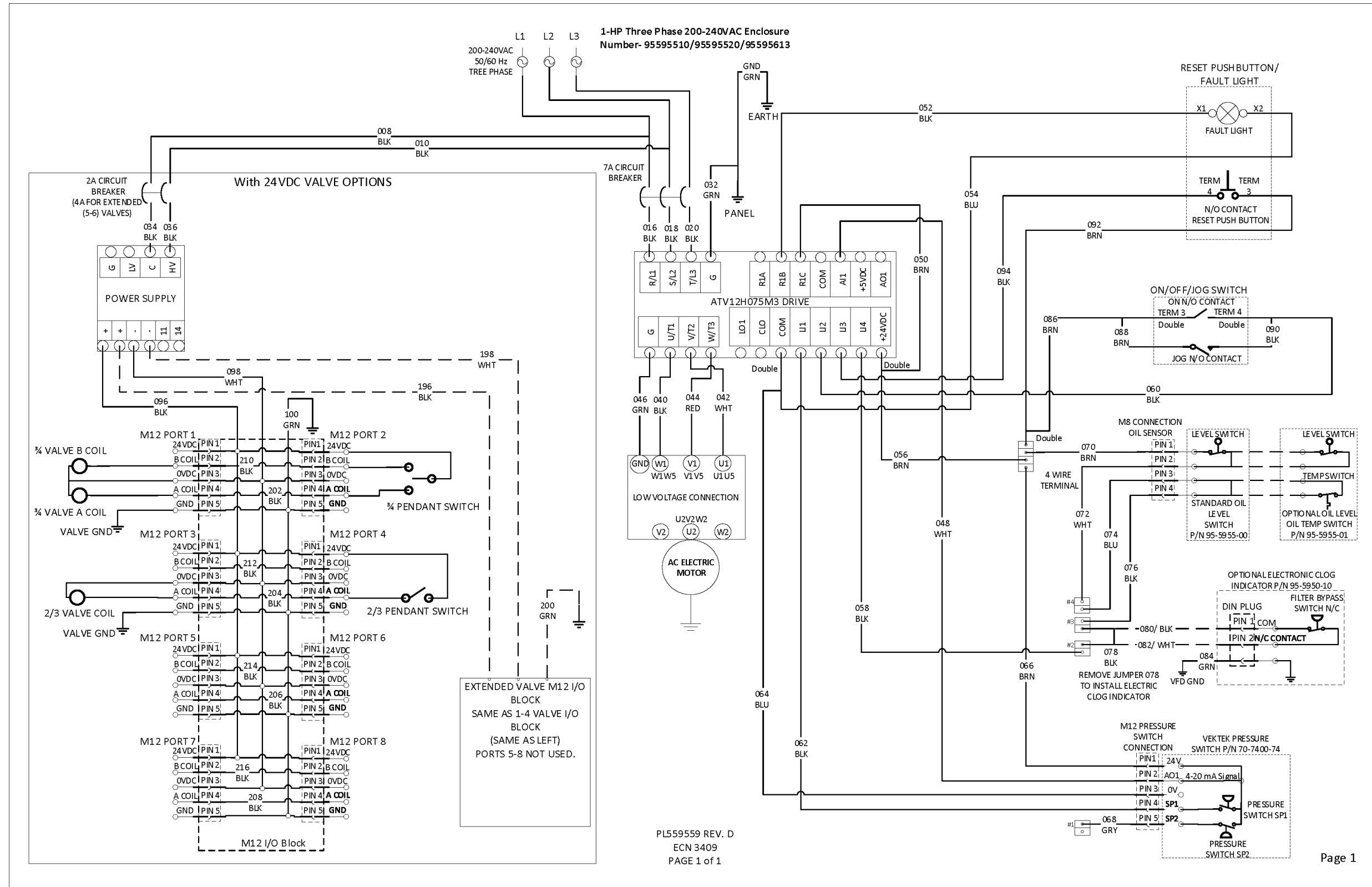

SECTION VI

MAINTENANCE (continued)

3. Three Phase 380-500VAC No Valve or Pendant Controlled Valve Enclosure

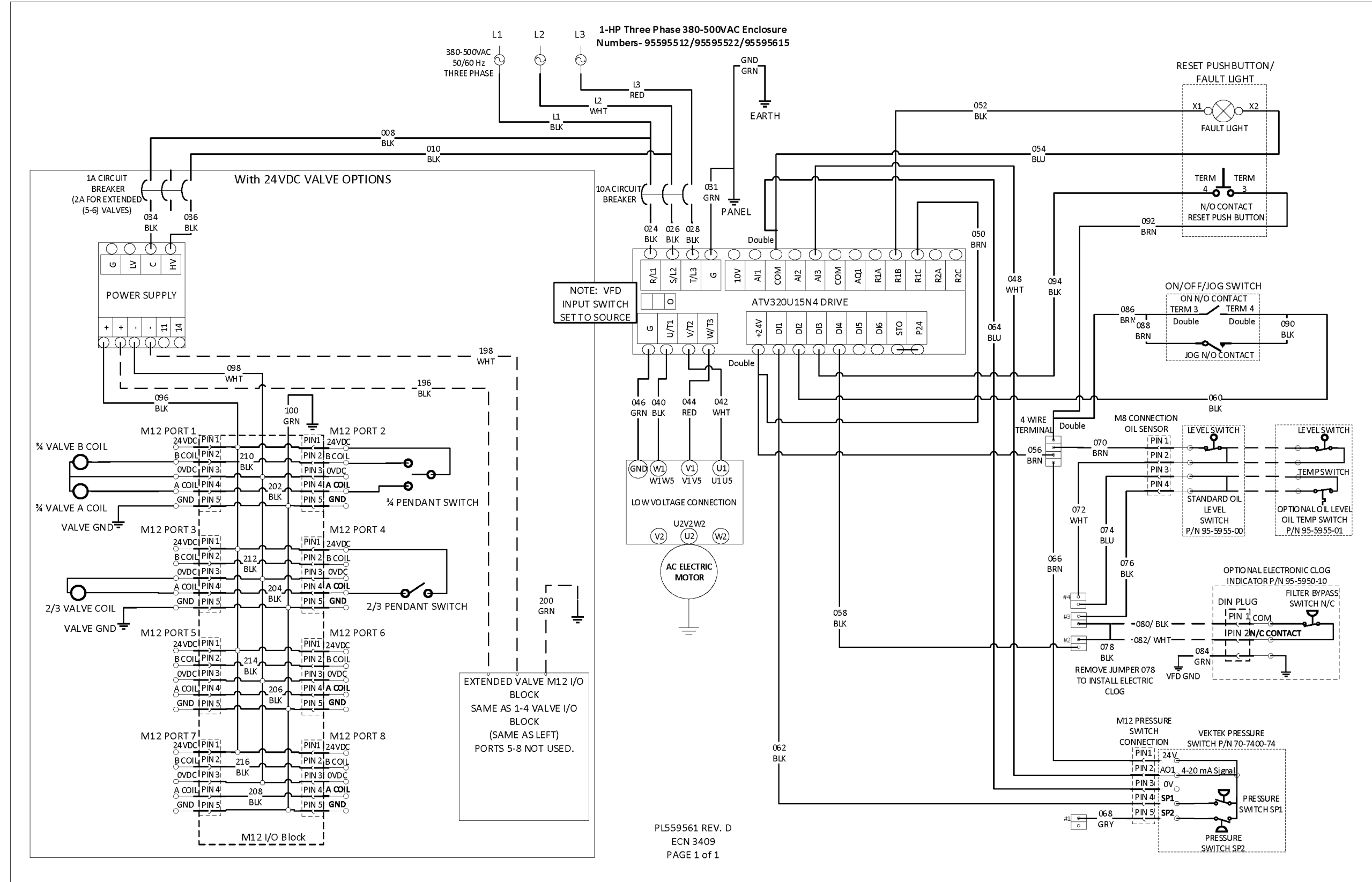

SECTION VI

MAINTENANCE (continued)

4. Three Phase 525-600VAC No Valve or Pendant Controlled Valve Enclosure

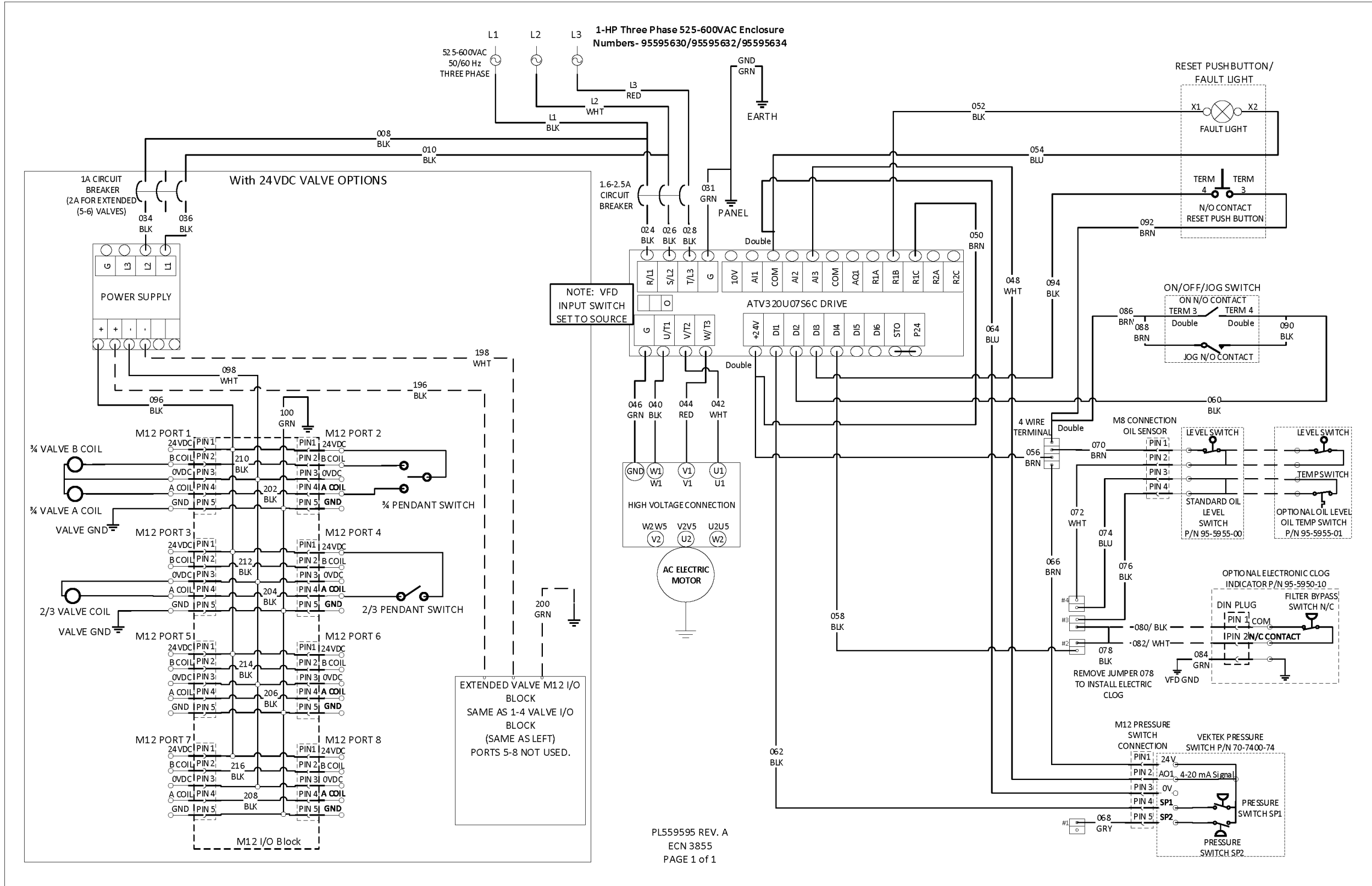

SECTION VI

MAINTENANCE (continued)

5. Single Phase 100-120VAC Machine Interface Enclosure Page 1 of 3

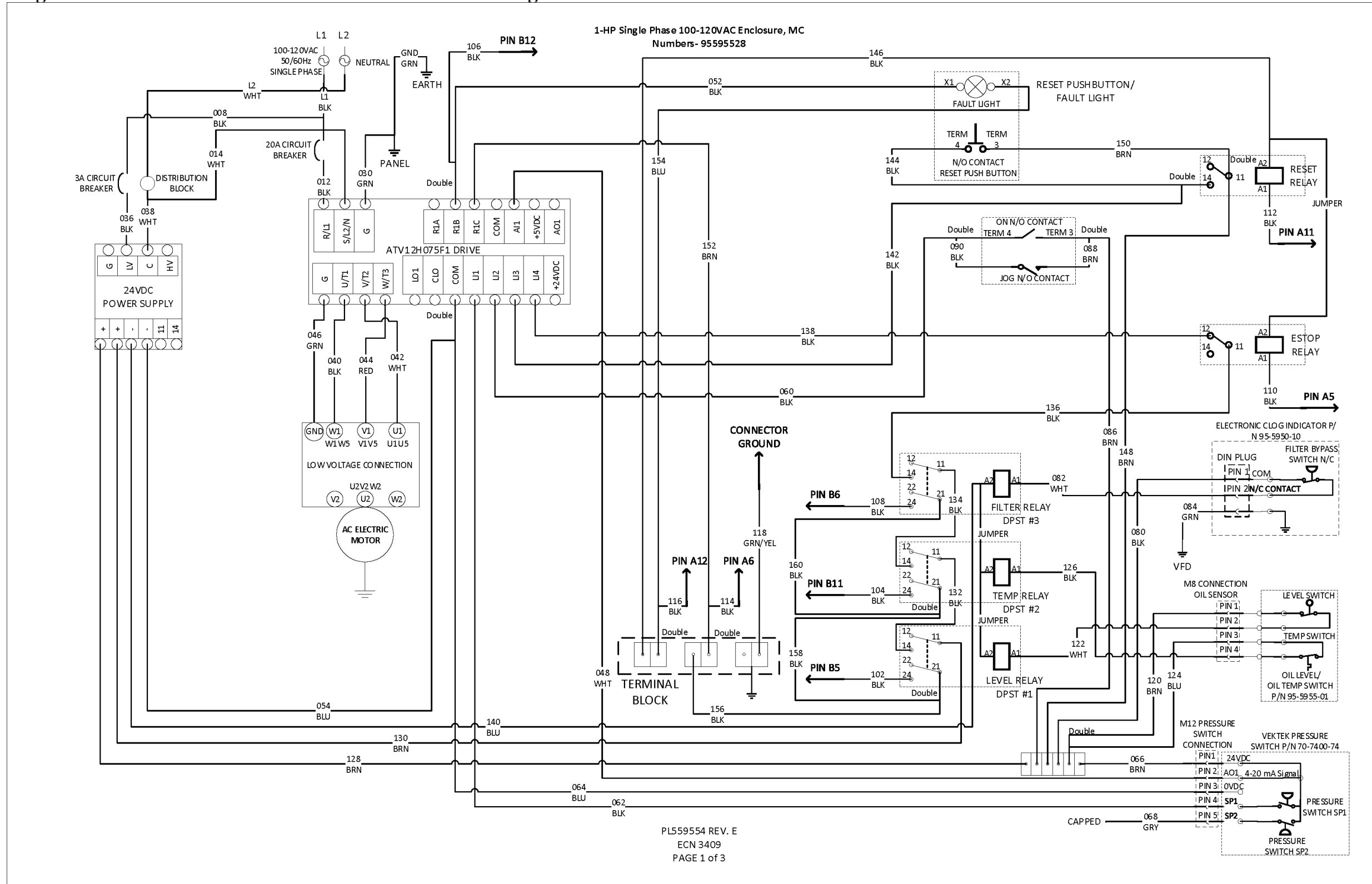

SECTION VI

MAINTENANCE (continued)

6. Single Phase 100-120VAC Machine Interface Enclosure Page 2 of 3

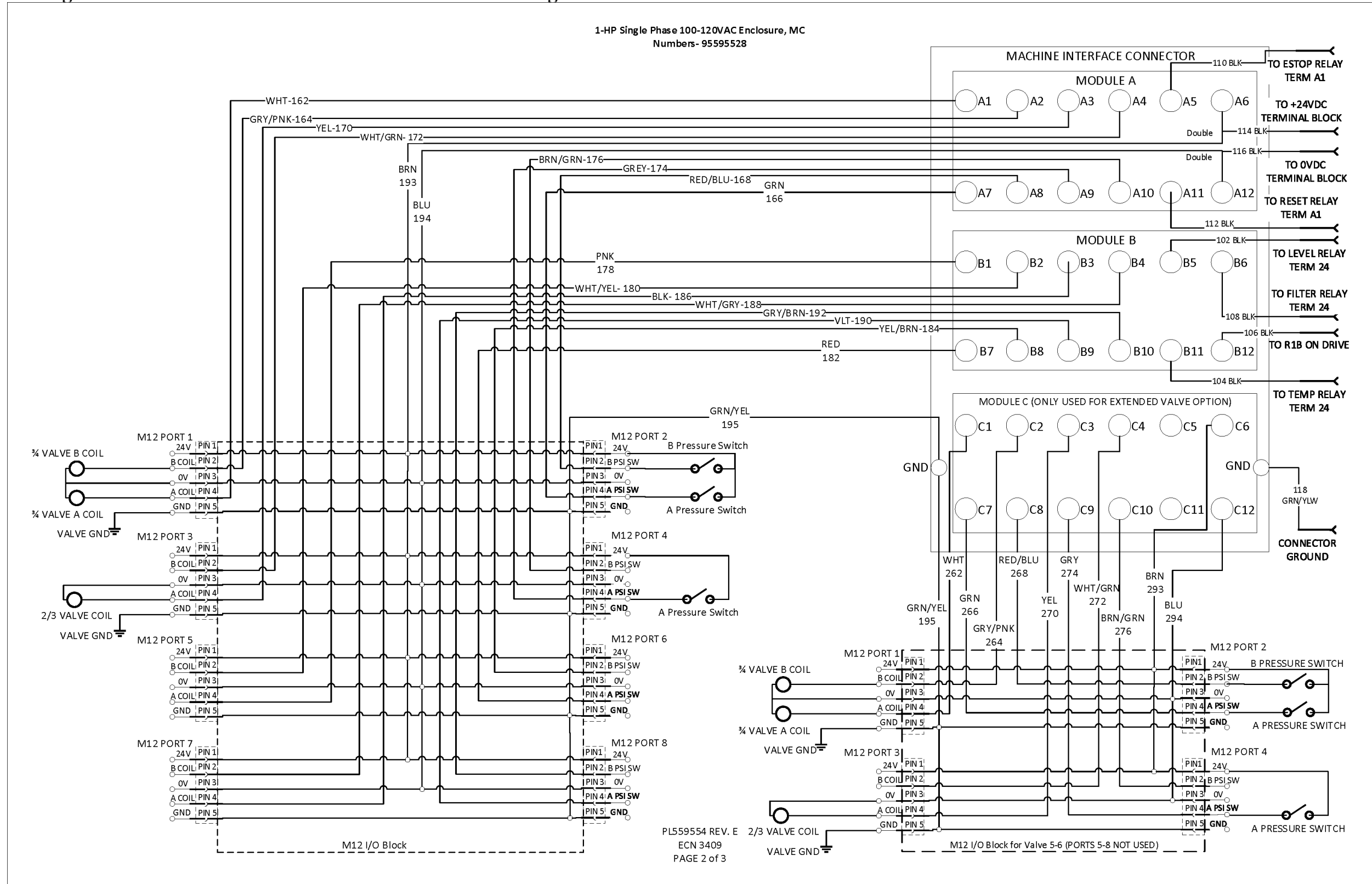

SECTION VI

MAINTENANCE (continued)

7. Single Phase 100-120VAC Machine Interface Enclosure with Power Page 3 of 3

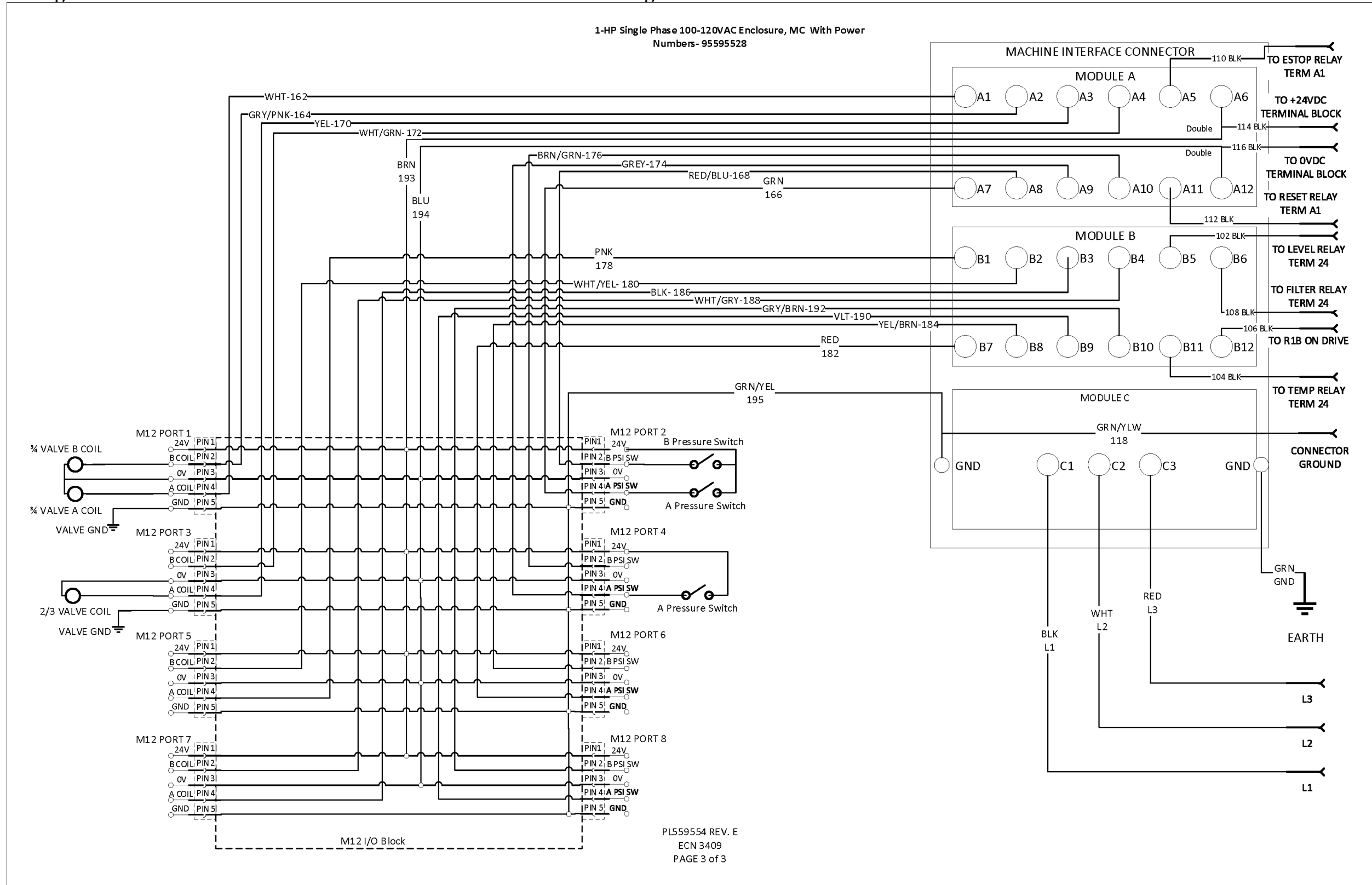

SECTION VI

MAINTENANCE (continued)

8. Three Phase 200-240VAC Machine Interface Enclosure Page 1 of 3

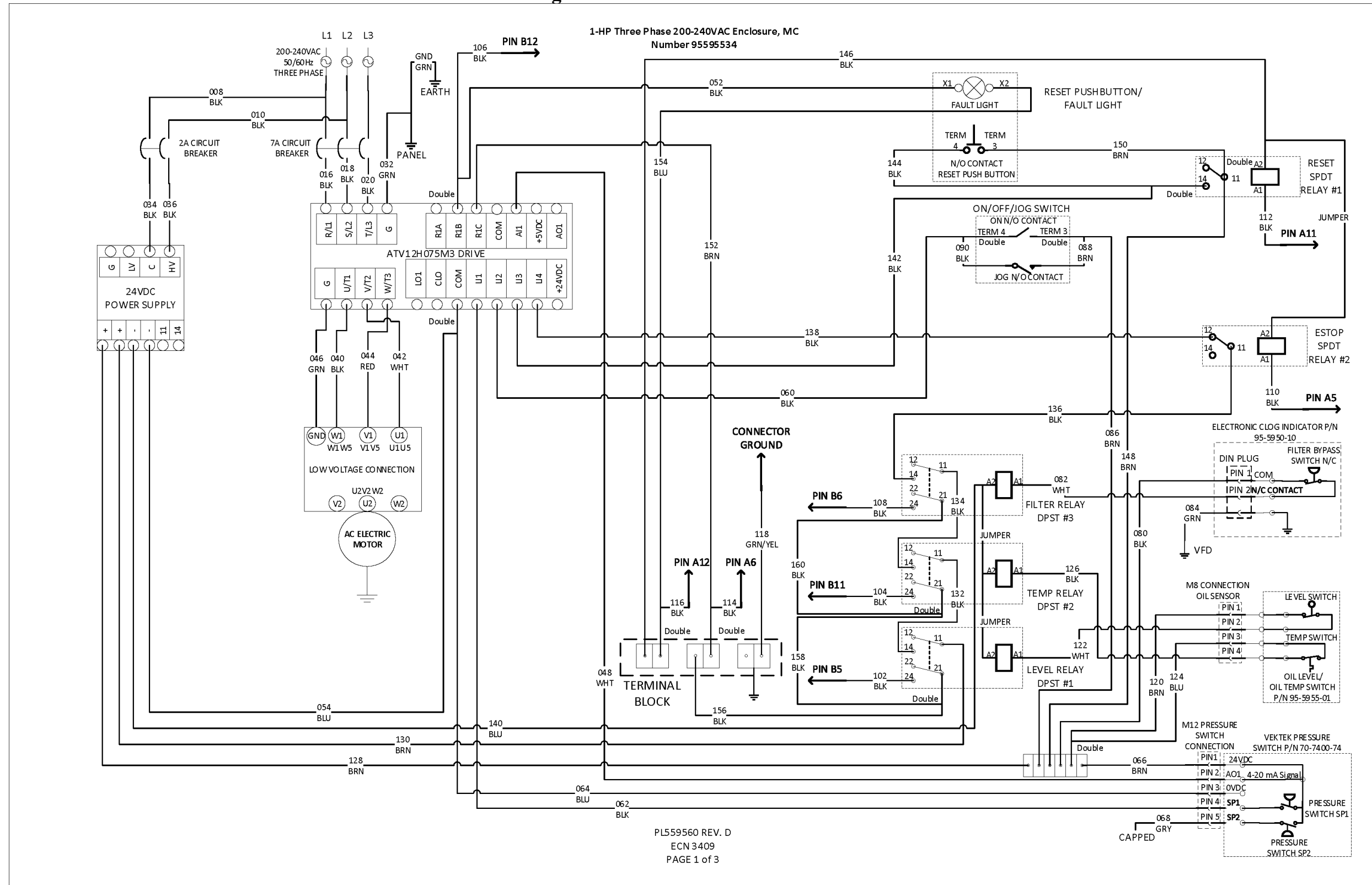

SECTION VI

MAINTENANCE (continued)

9. Three Phase 200-240VAC Machine Interface Enclosure Page 2 of 3

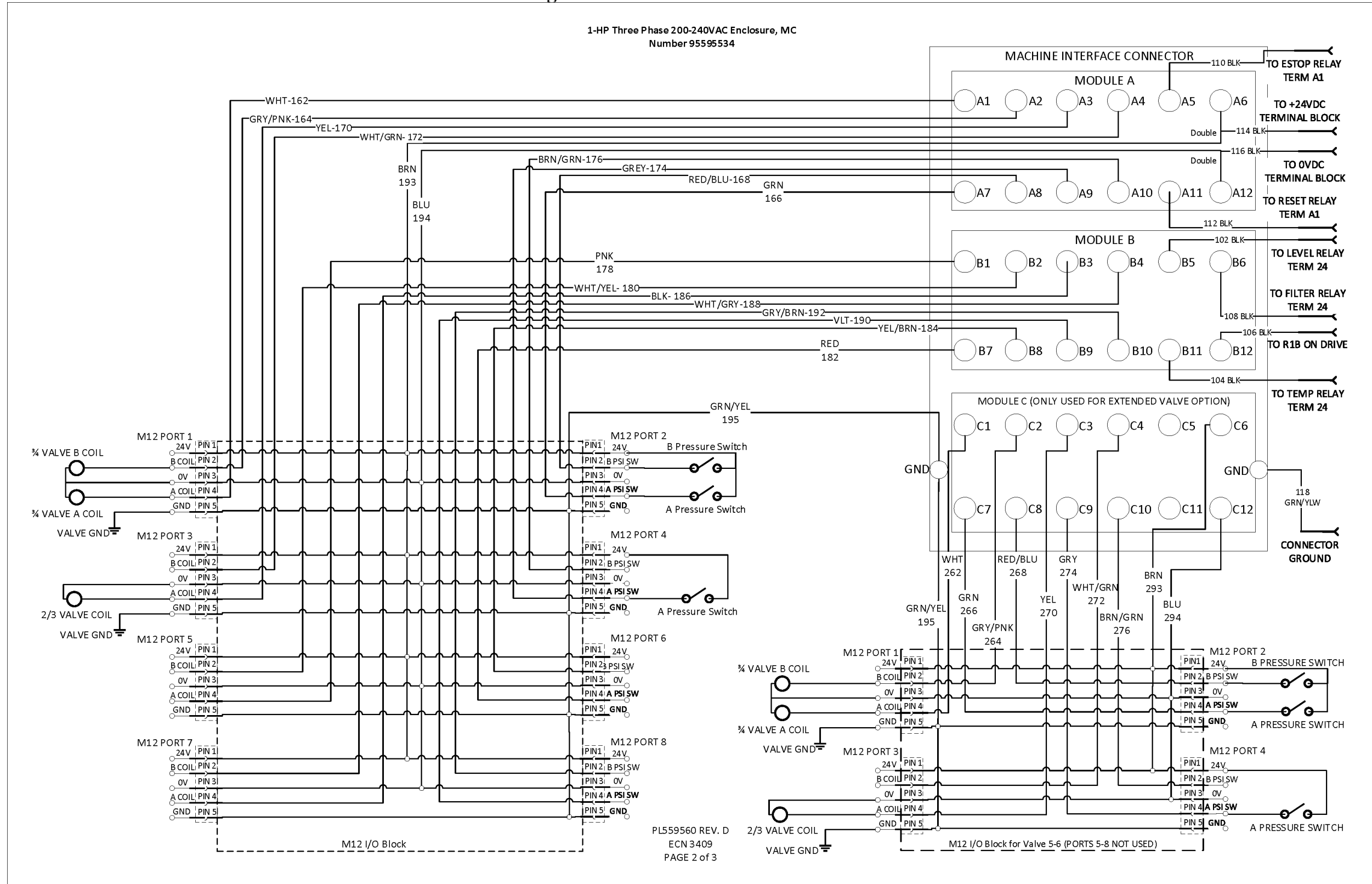

SECTION VI

MAINTENANCE (continued)

10. Three Phase 200-240VAC Machine Interface Enclosure with Power Page 3 of 3

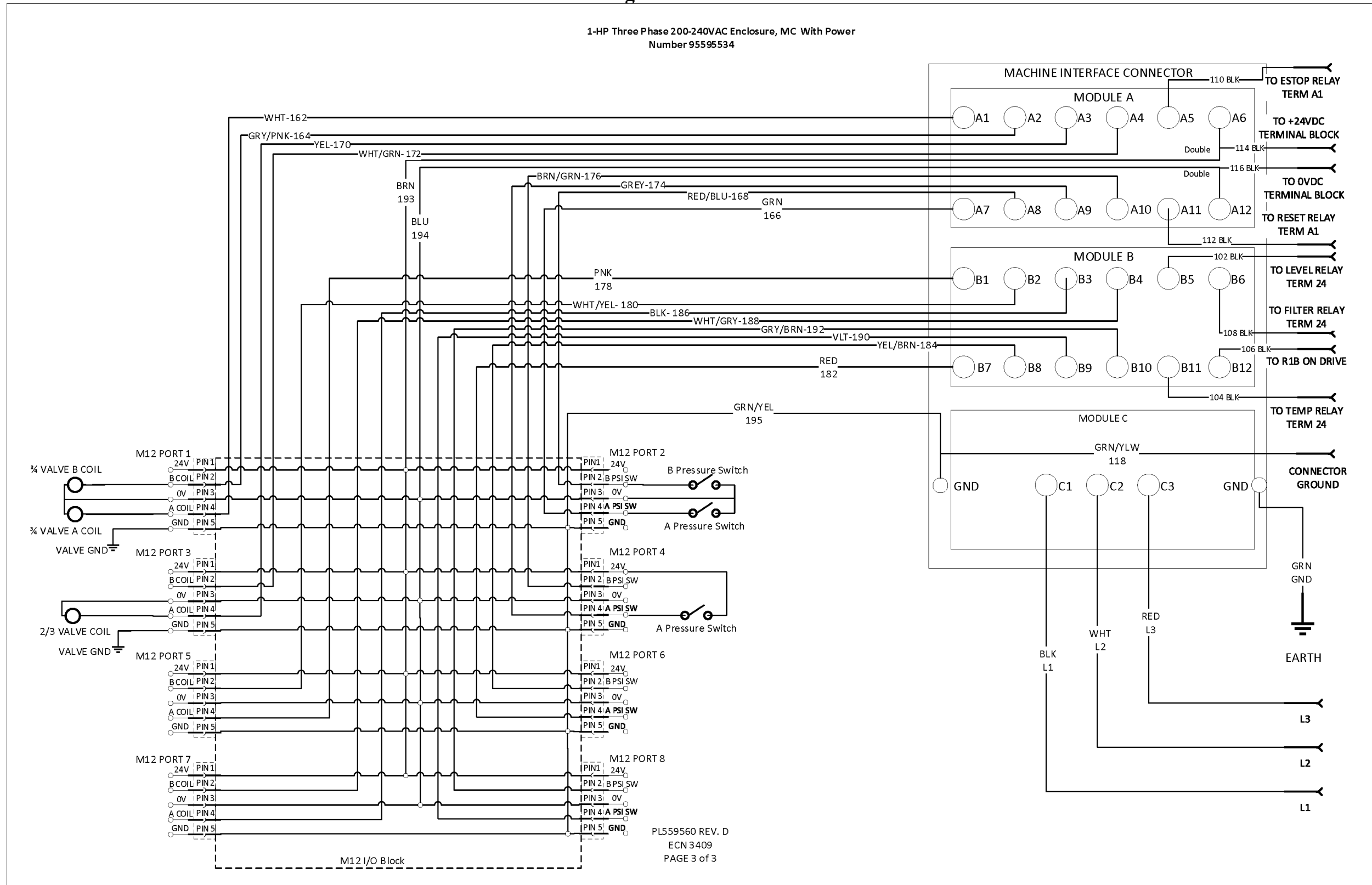

SECTION VI

MAINTENANCE (continued)

11. Three Phase 380-500VAC Machine Interface Enclosure Page 1 of 3

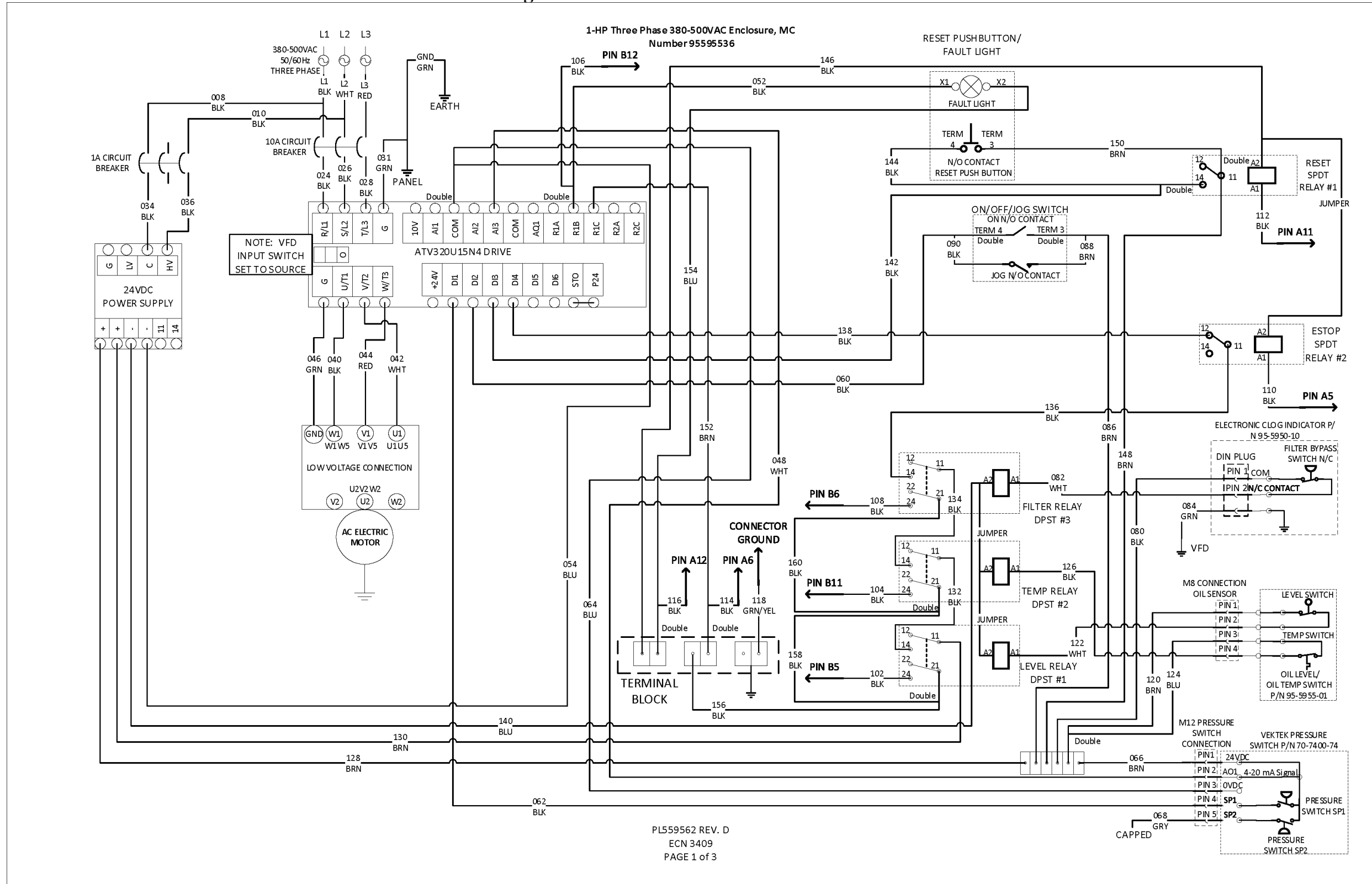

SECTION VI

MAINTENANCE (continued)

12. Three Phase 380-500VAC Machine Interface Enclosure Page 2 of 3

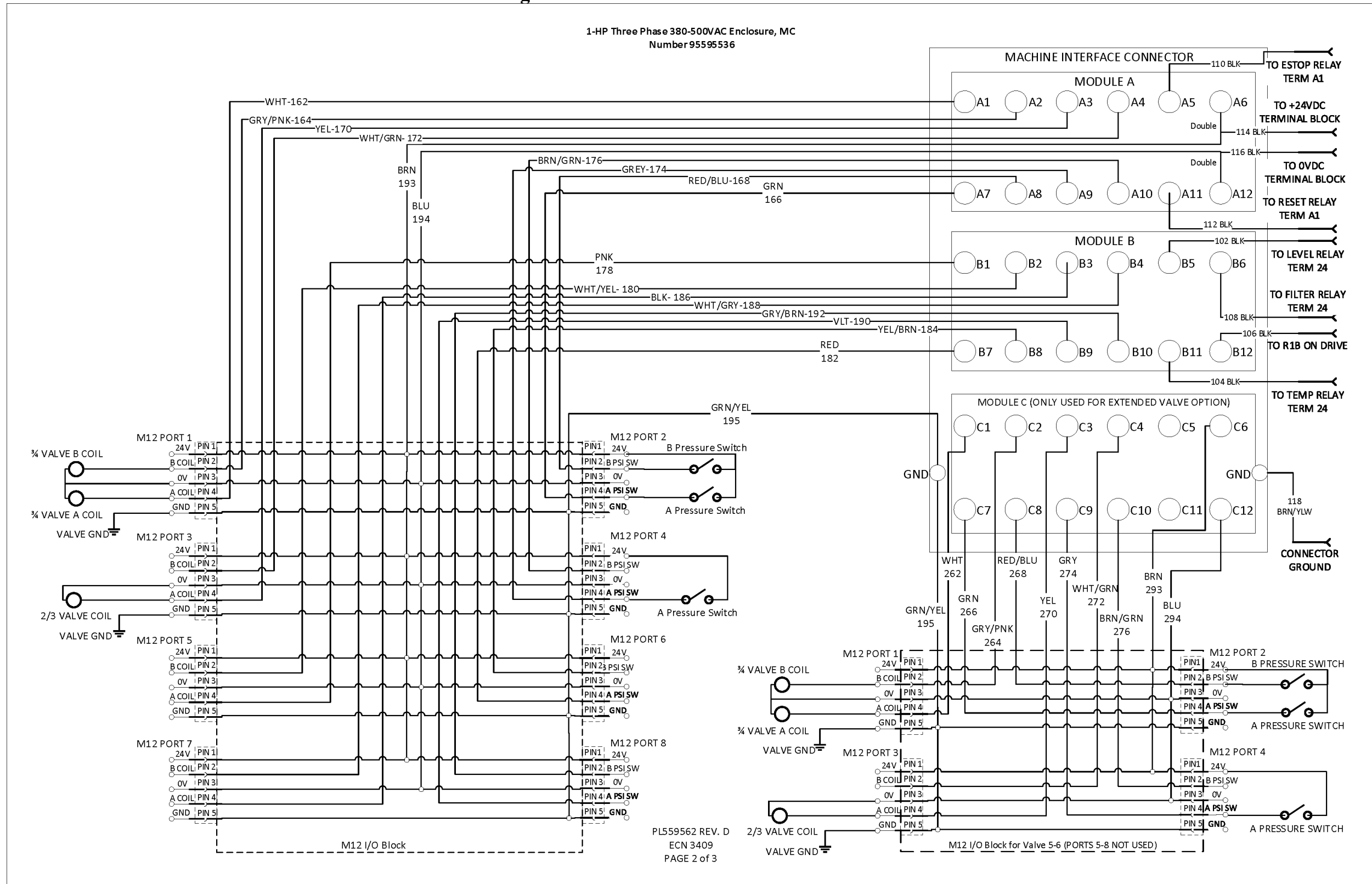

SECTION VI

MAINTENANCE (continued)

13. Three Phase 380-500VAC Machine Interface Enclosure with Power Page 3 of 3

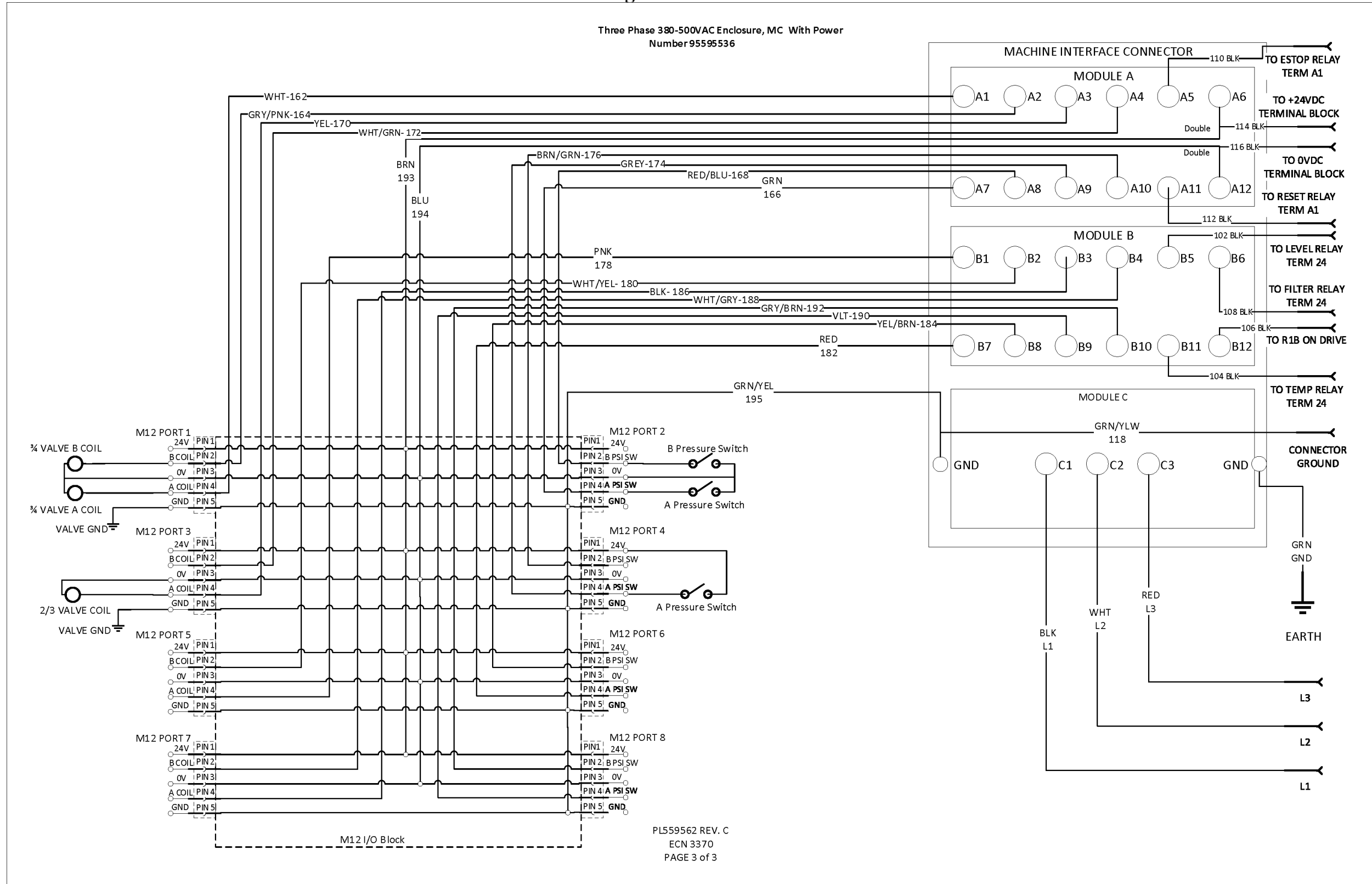

SECTION VI

MAINTENANCE (continued)

14. Three Phase 525-600VAC Machine Interface Enclosure with Page 1 of 3

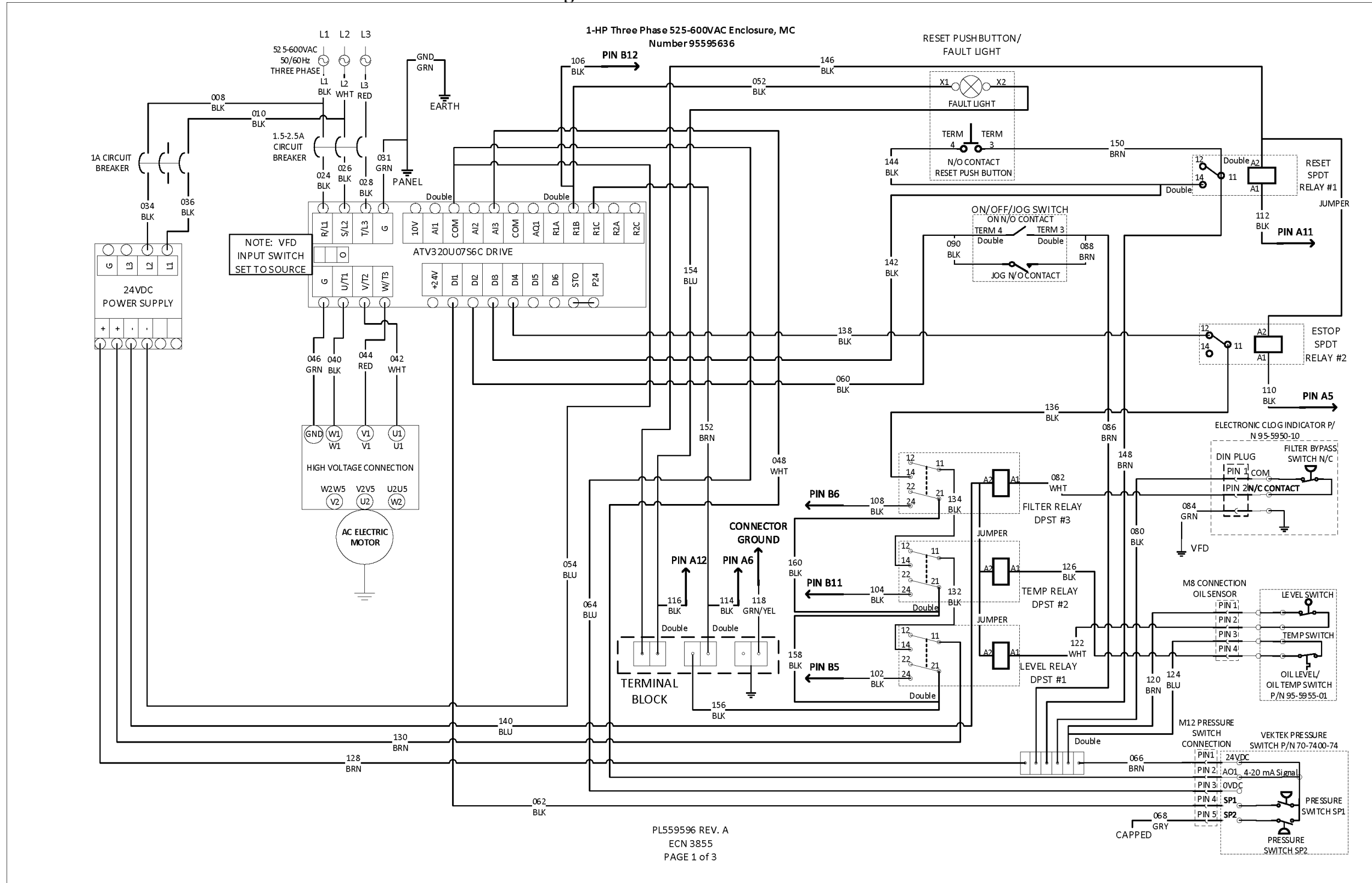

SECTION VI

MAINTENANCE (continued)

15. Three Phase 525-600VAC Machine Interface Enclosure Page 2 of 3

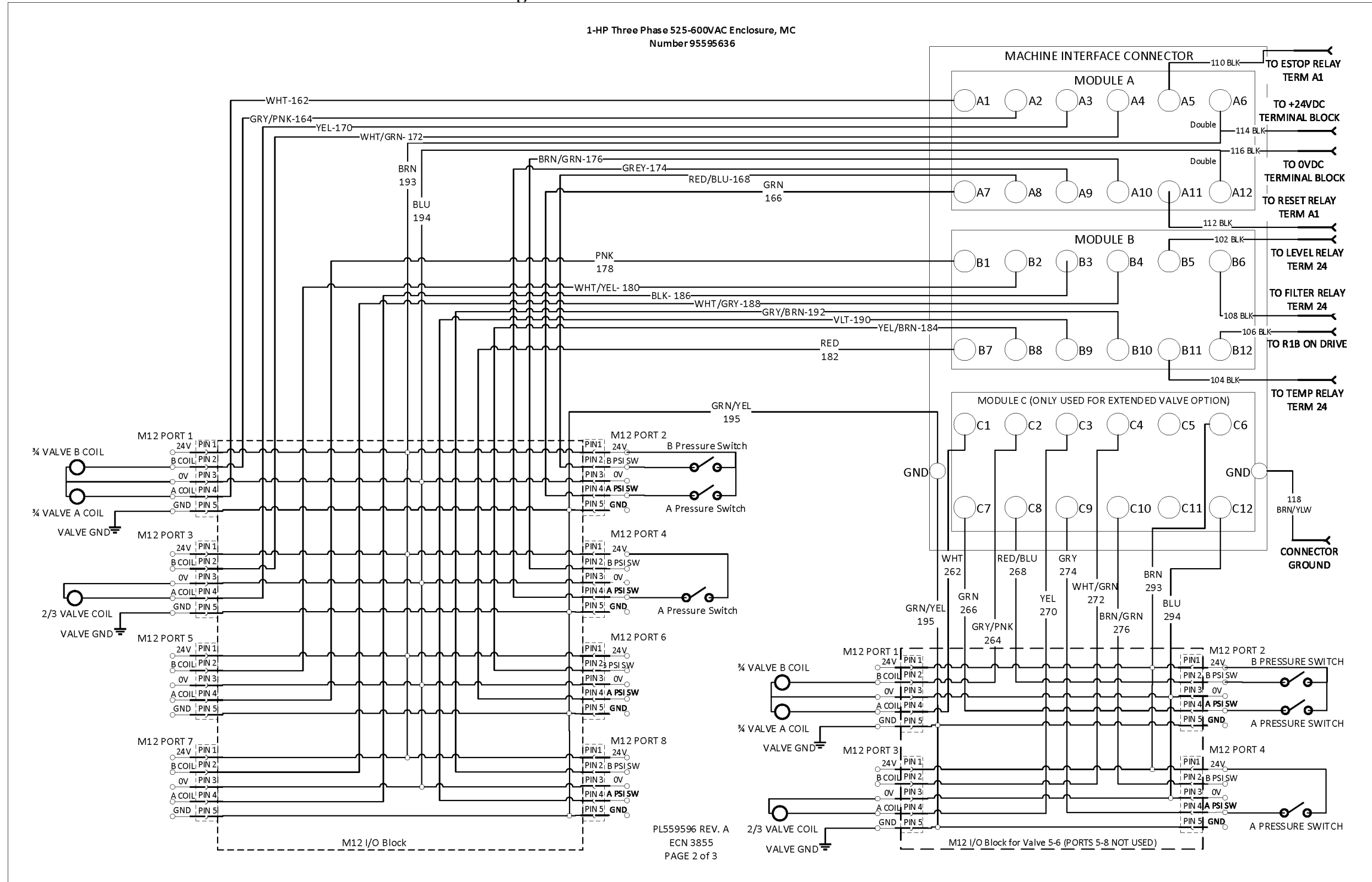

SECTION VI

MAINTENANCE (continued)

16. Three Phase 525-600VAC Machine Interface Enclosure with Power Page 3 of 3

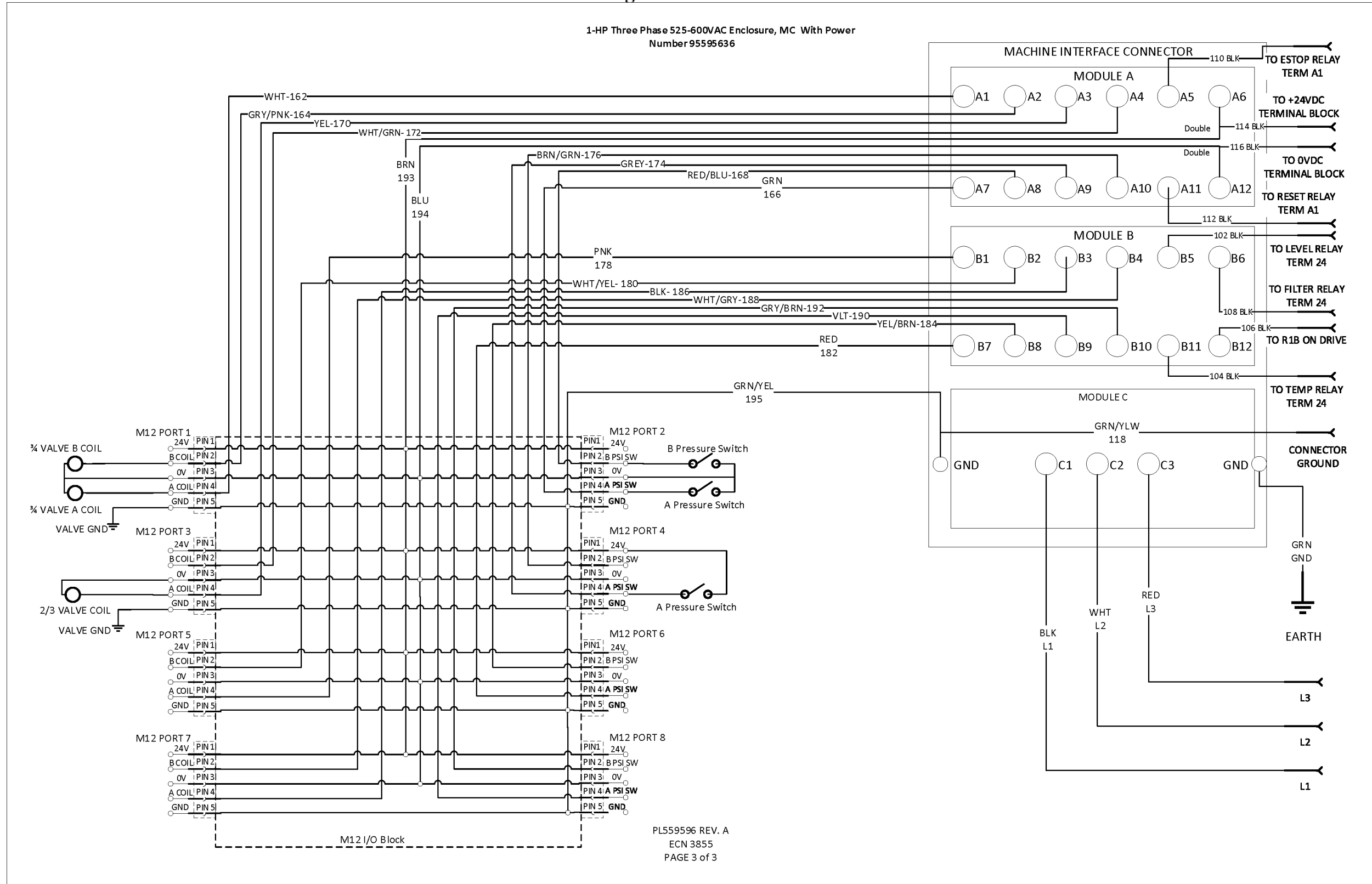

SECTION VI

MAINTENANCE (continued)

17. Single or Three Phase, 100-500VAC, Hydraulic Pump Interface Unit, 1-4 Valves

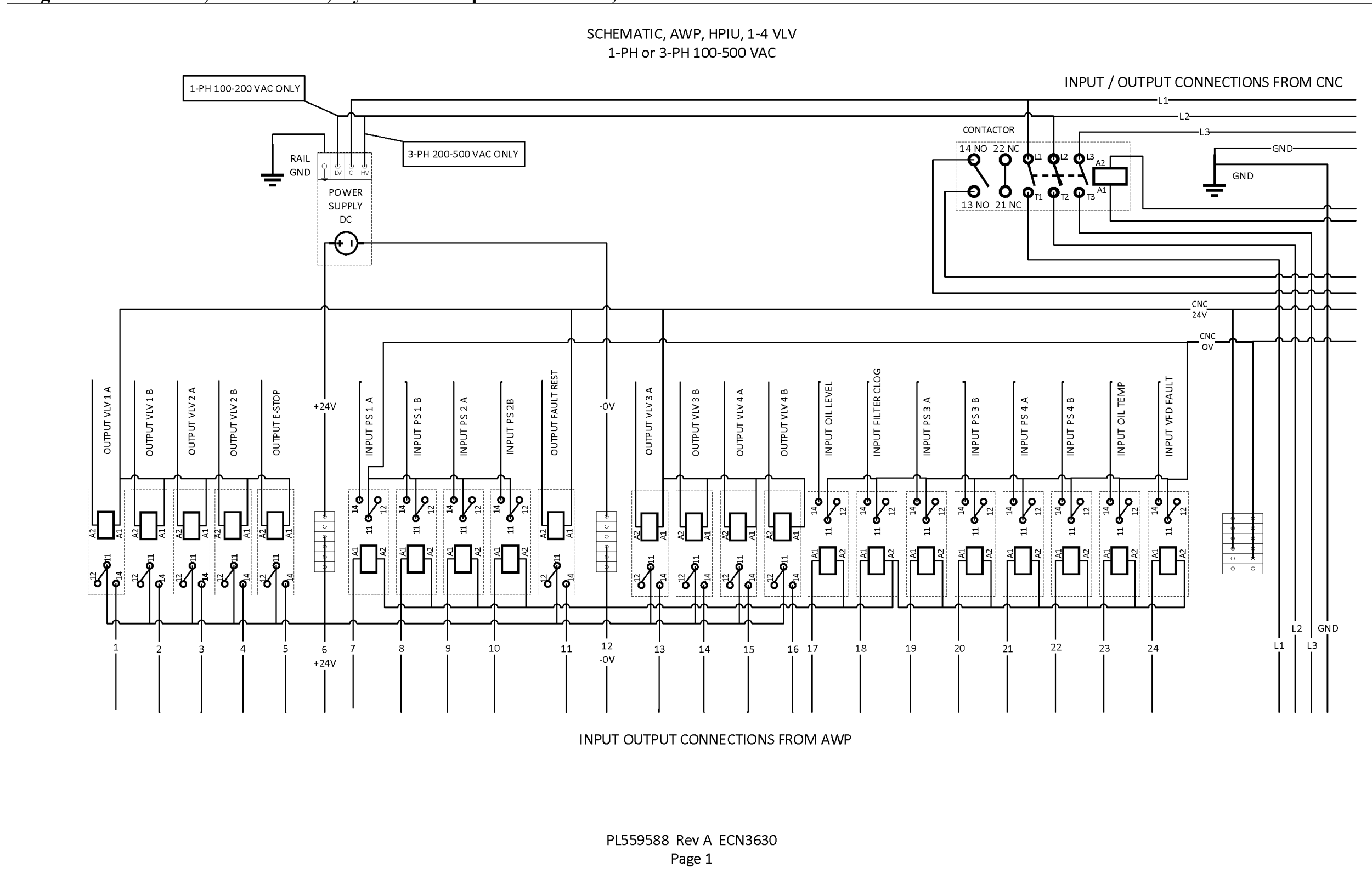

SECTION VI

MAINTENANCE (continued)

18. Single or Three Phase, 100-500VAC, Hydraulic Pump Interface Unit, 5-6 Valves

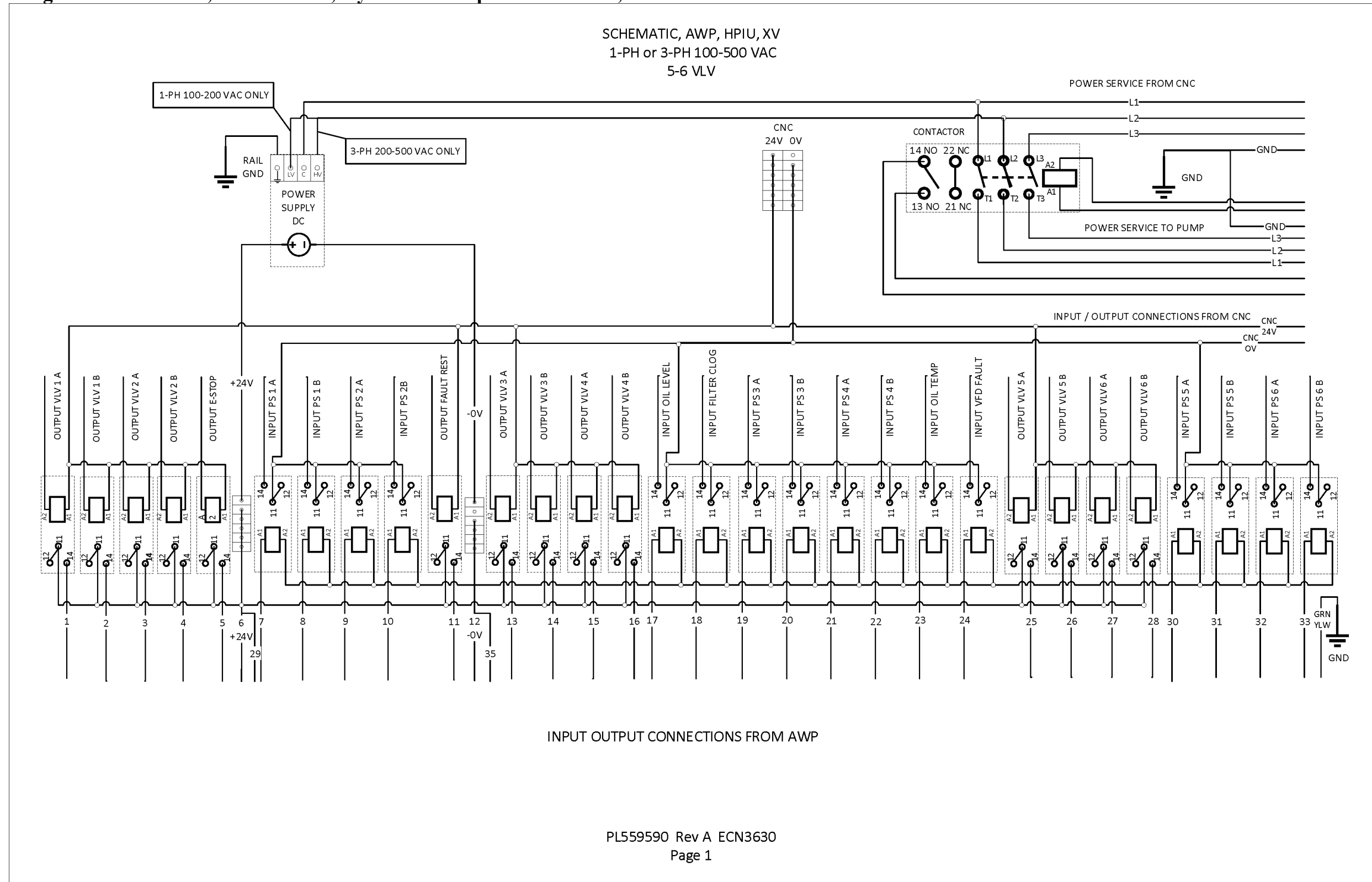

SECTION VI

MAINTENANCE (continued)

19. Three Phase 200-240VAC Machine Interface Enclosure, OKUMA Ethernet Page 1 of 2

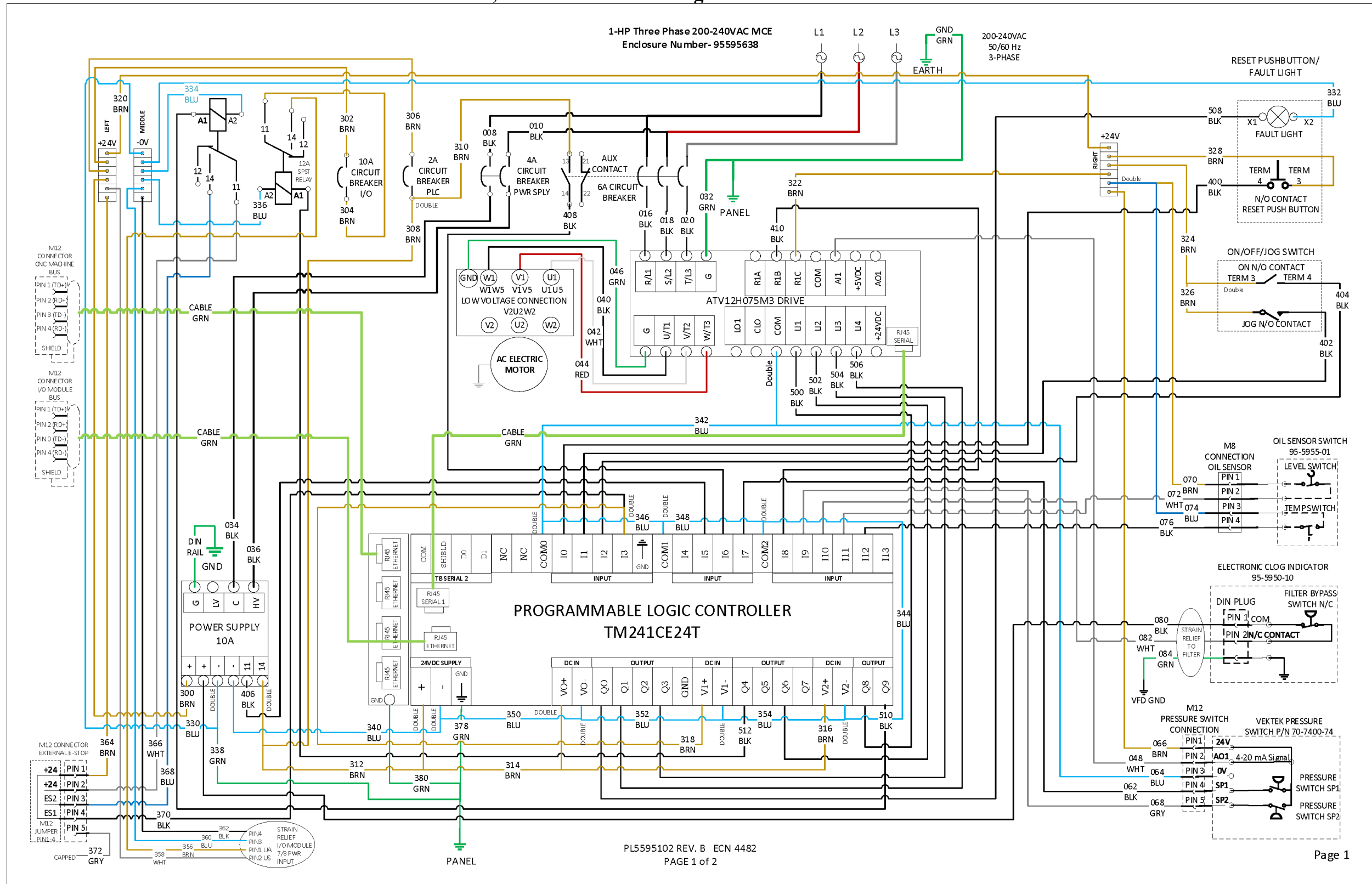

SECTION VI

MAINTENANCE (continued)

20. Three Phase 200-240VAC Machine Interface Enclosure, OKUMA Ethernet Page 2 of 2

1-HP Three Phase 200-240VAC MCE
Enclosure Number- 95595638

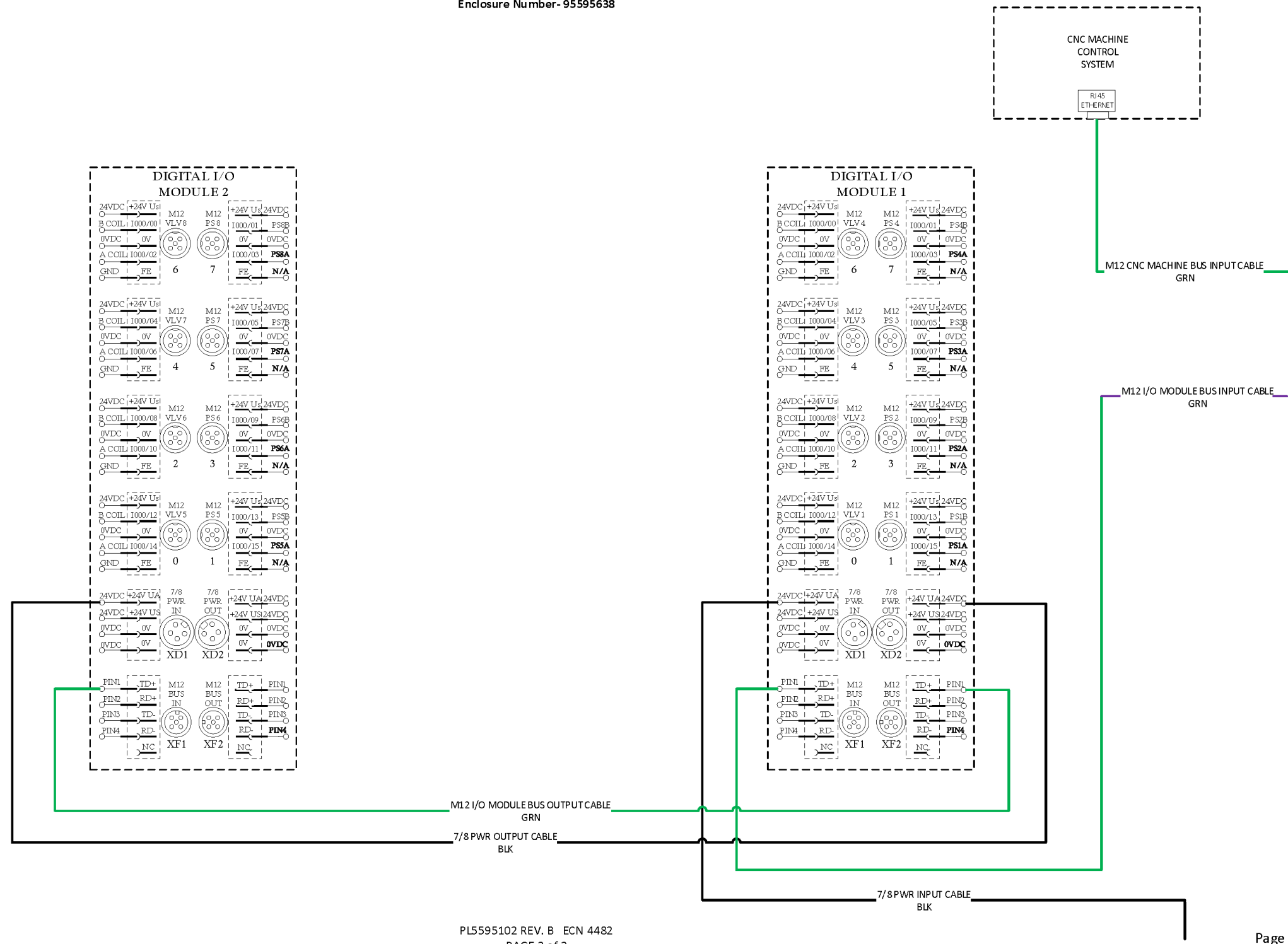

PL5595102 REV. B ECN 4482
PAGE 2 of 2

Page 2

SECTION VI

MAINTENANCE (continued)

21. Three Phase 380-500VAC Machine Interface Enclosure, OKUMA Ethernet Page 1 of 2

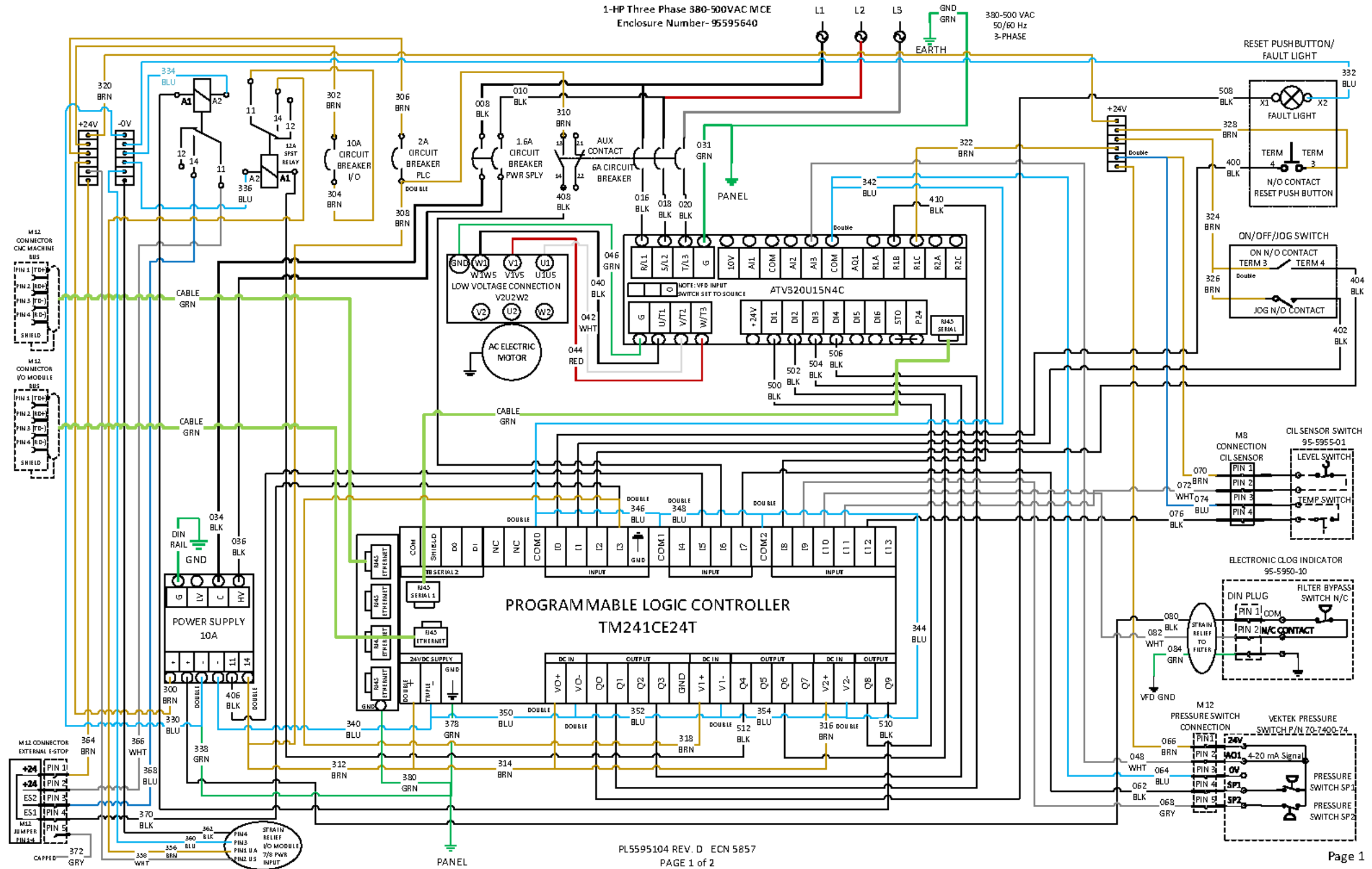

SECTION VI

MAINTENANCE (continued)

22. Three Phase 380-500VAC Machine Interface Enclosure, OKUMA Ethernet Page 2 of 2

1-HP Three Phase 380-500VAC MCE
Enclosure Number-95595640

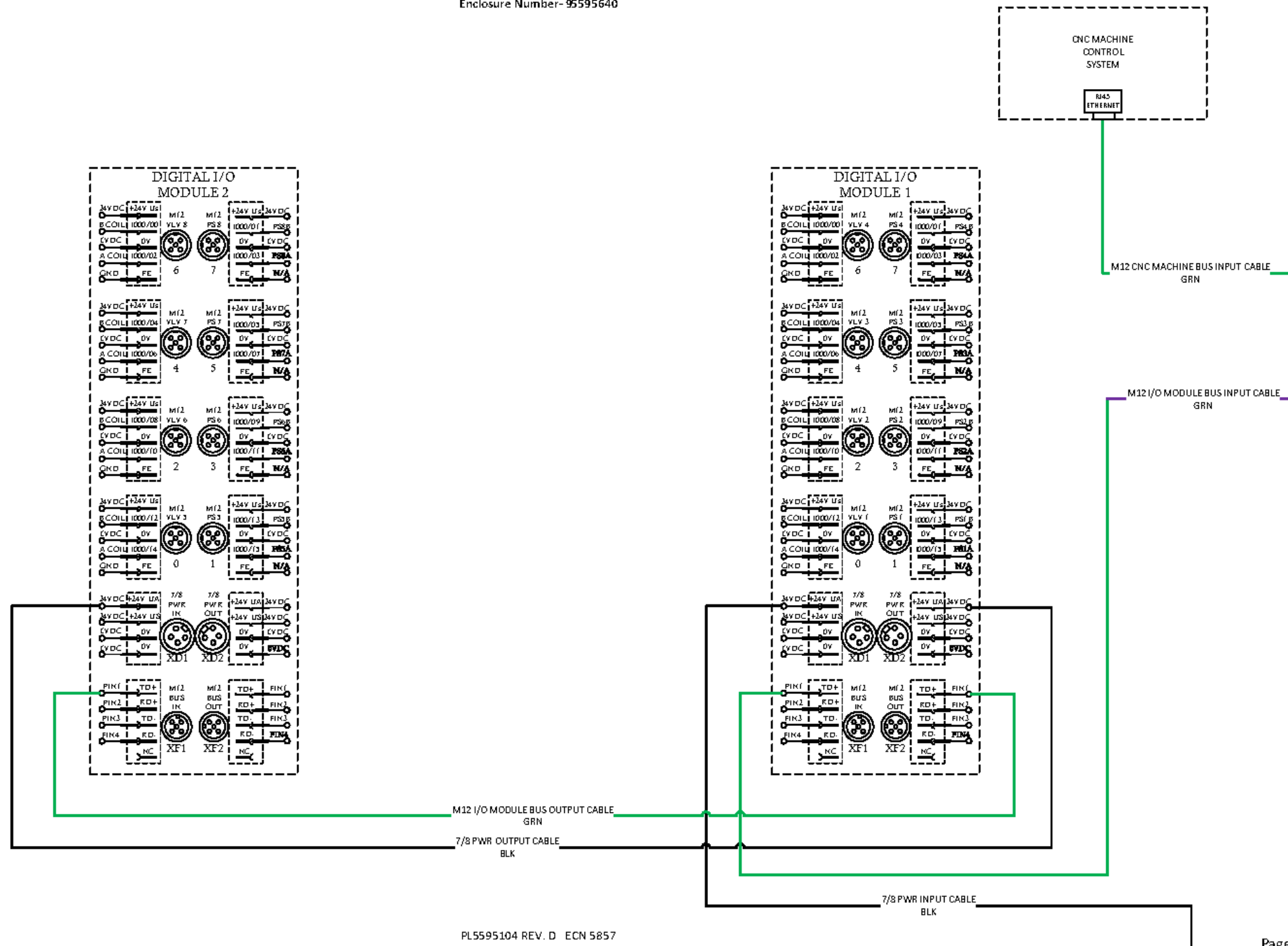

PL5595104 REV. D ECN 5857
PAGE 2 of 2

SECTION VI

MAINTENANCE (continued)

23. Three Phase 525-600VAC Machine Interface Enclosure, OKUMA Ethernet Page 1 of 2

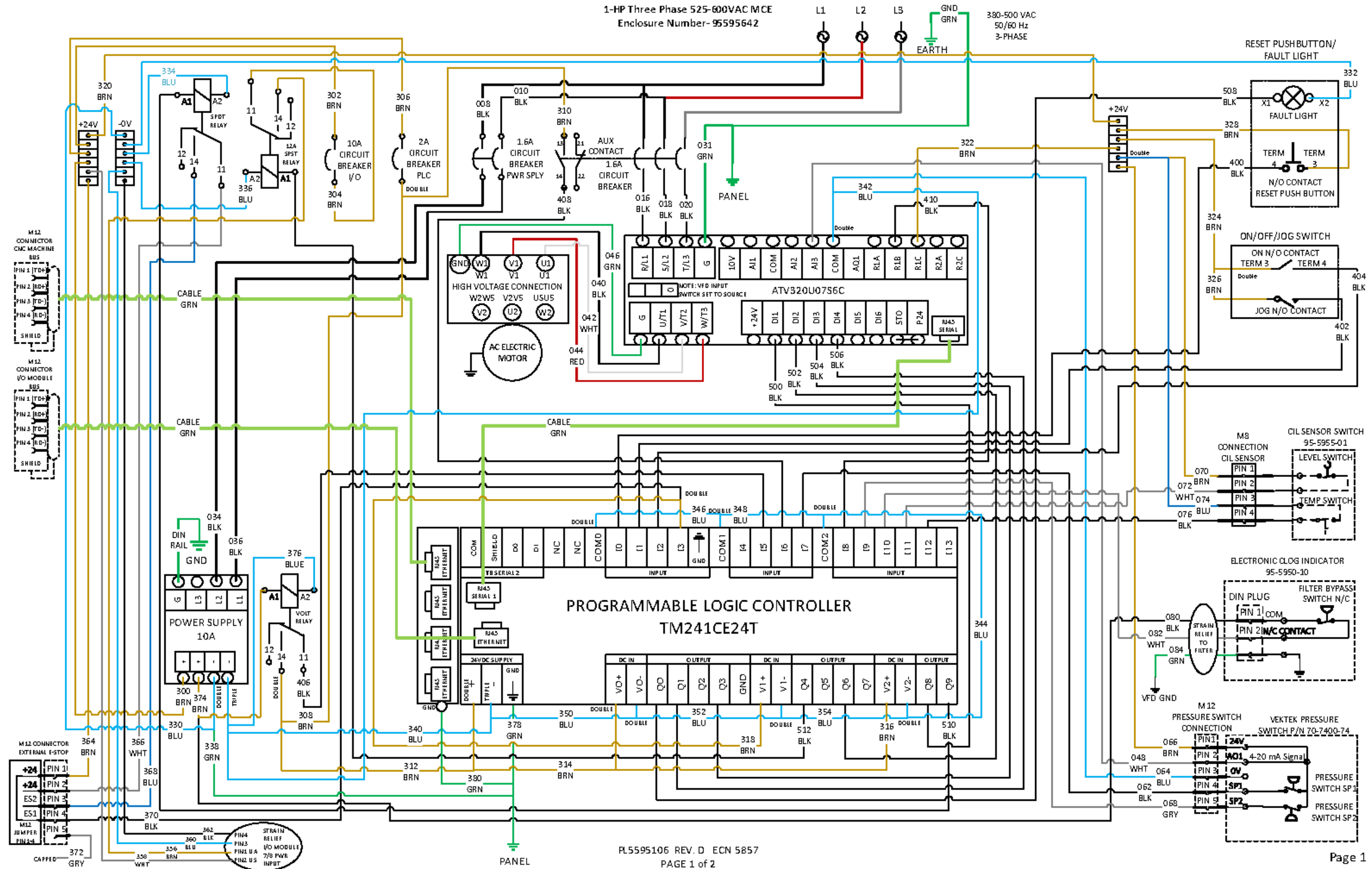

SECTION VI

MAINTENANCE (continued)

24. Three Phase 525-600VAC Machine Interface Enclosure, OKUMA Ethernet Page 2 of 2

1-HP Three Phase 525-600VAC MCE
Enclosure Number-95595642

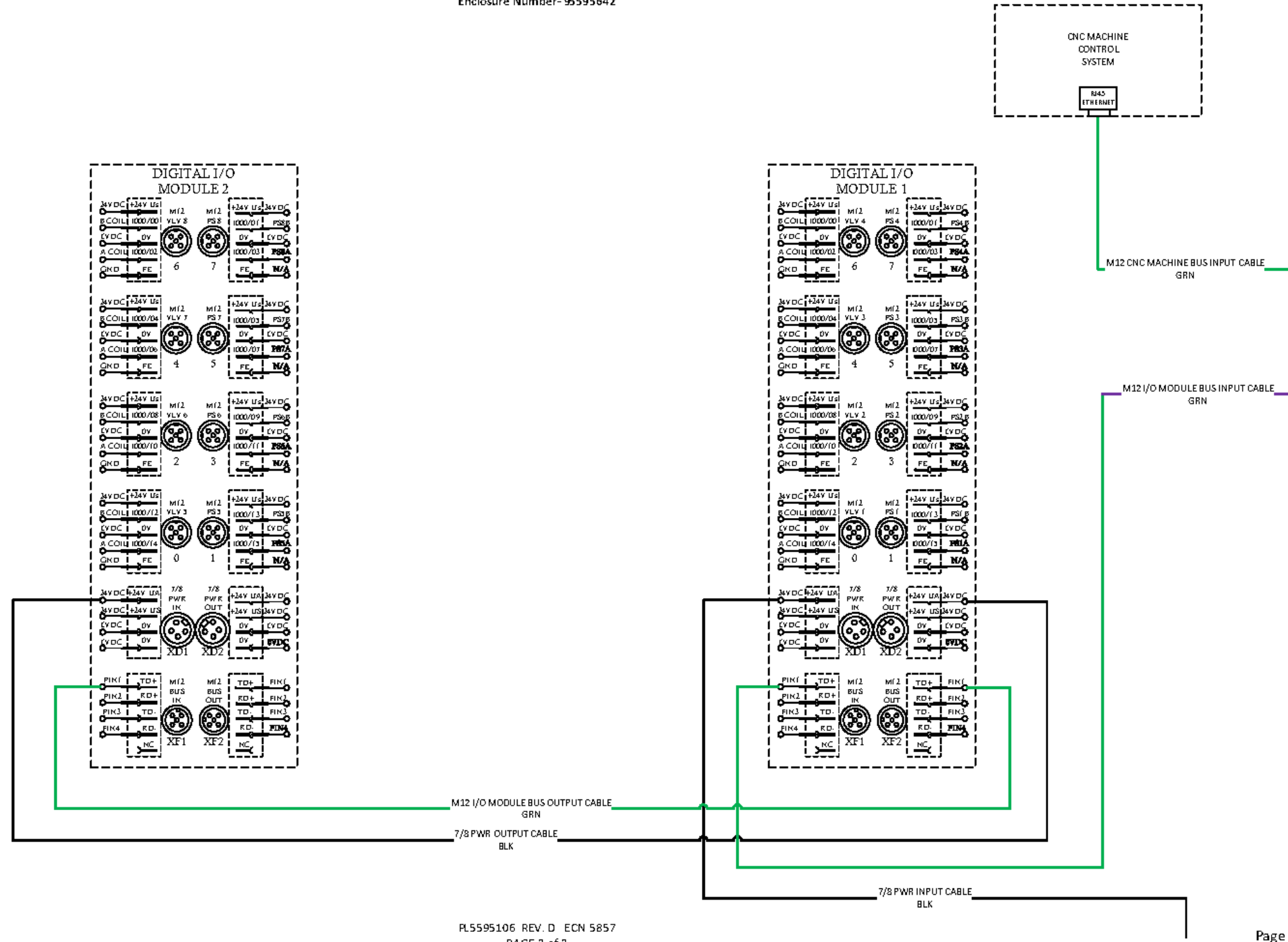

PL5595106 REV. D ECN 5857
PAGE 2 of 2

SECTION VI

MAINTENANCE (continued)

25. Three Phase 200-240VAC Machine Interface Enclosure, HMI Ethernet Page 1 of 2

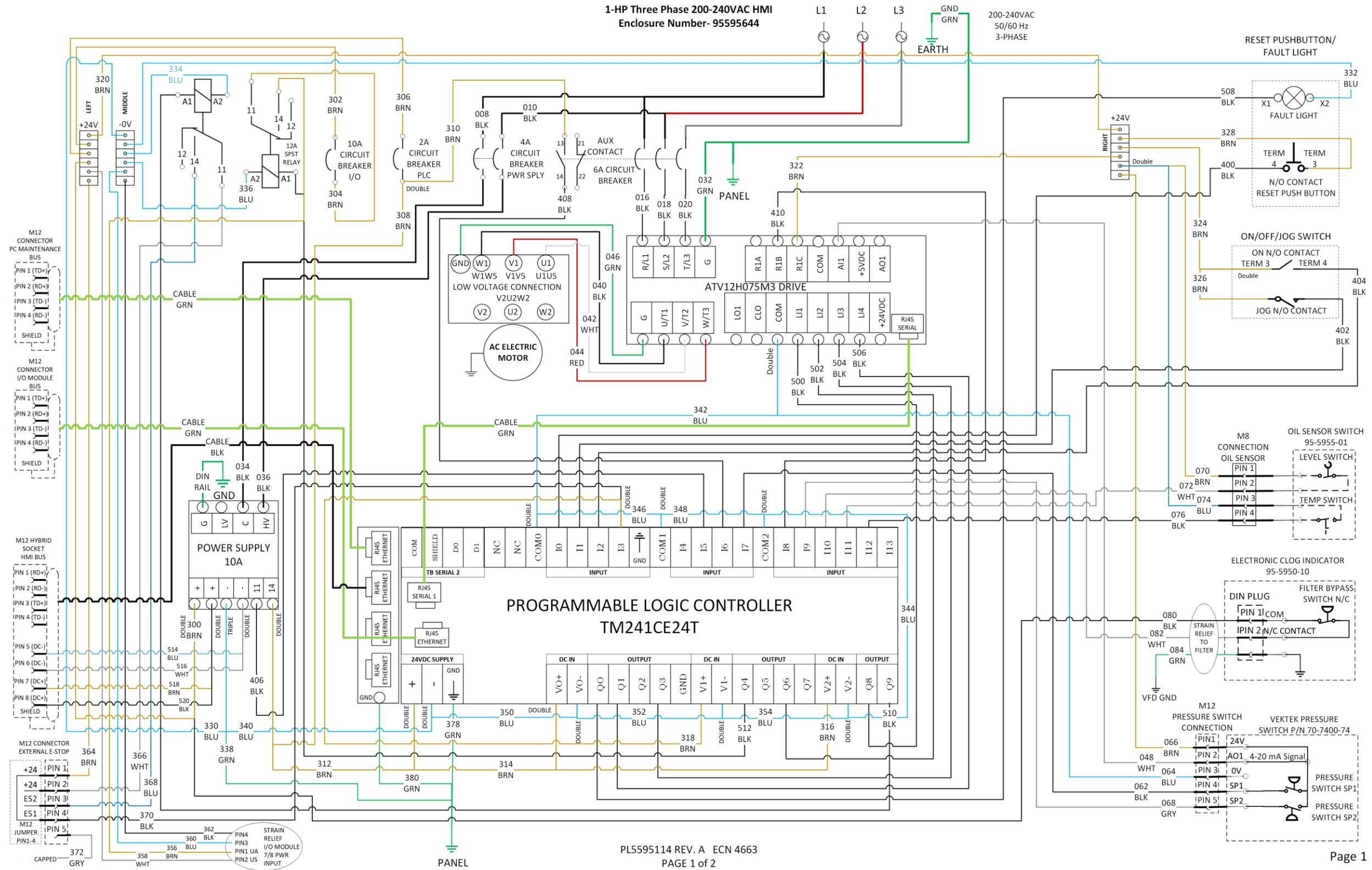

SECTION VI

MAINTENANCE (continued)

26. Three Phase 200-240VAC Machine Interface Enclosure, HMI Ethernet Page 2

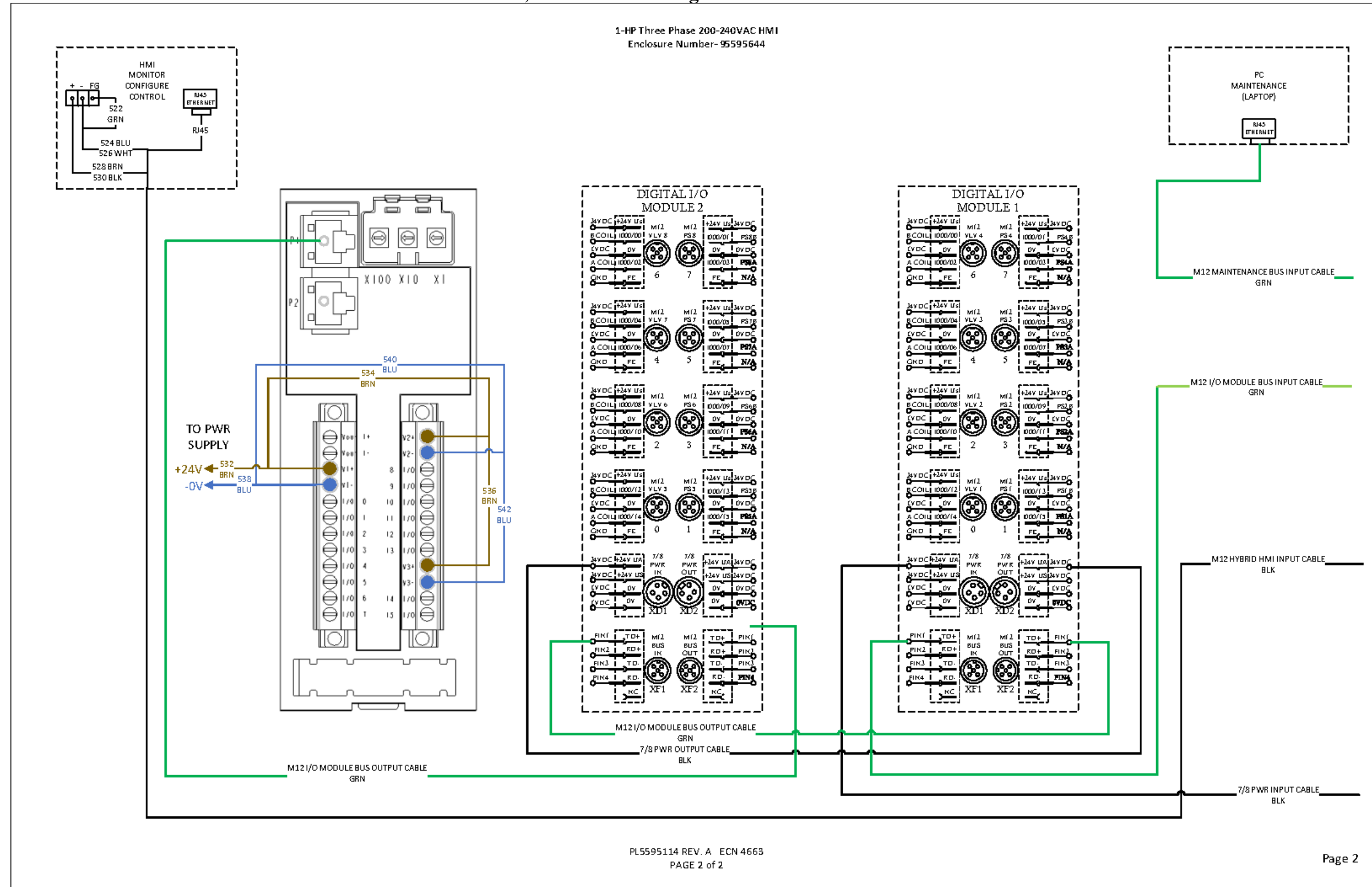

SECTION VI

MAINTENANCE (continued)

27. Three Phase 380-500VAC Machine Interface Enclosure, HMI Ethernet Page 1 of 2

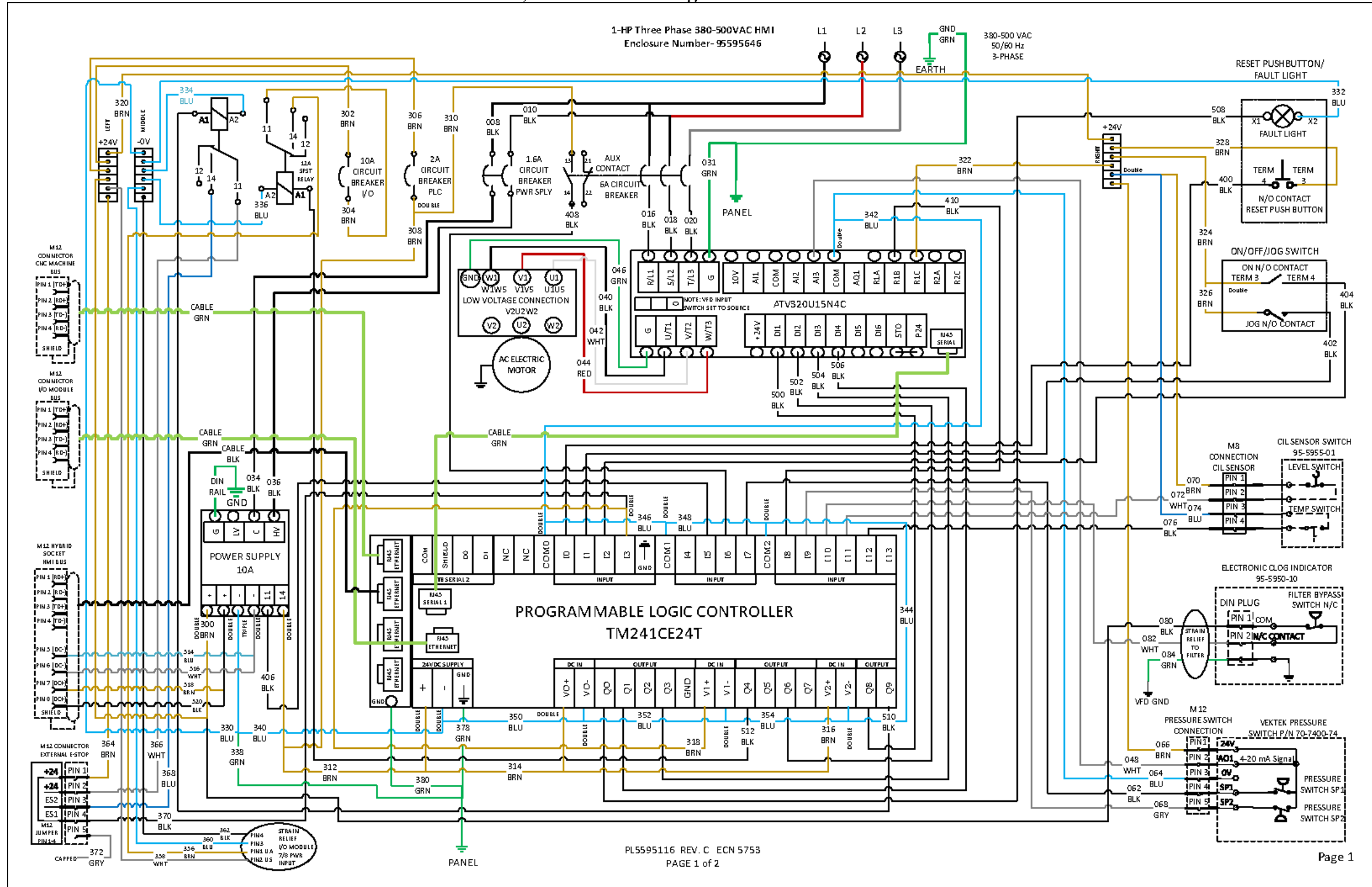

SECTION VI

MAINTENANCE (continued)

28. Three Phase 380-500VAC Machine Interface Enclosure, HMI Ethernet Page 2 of 2

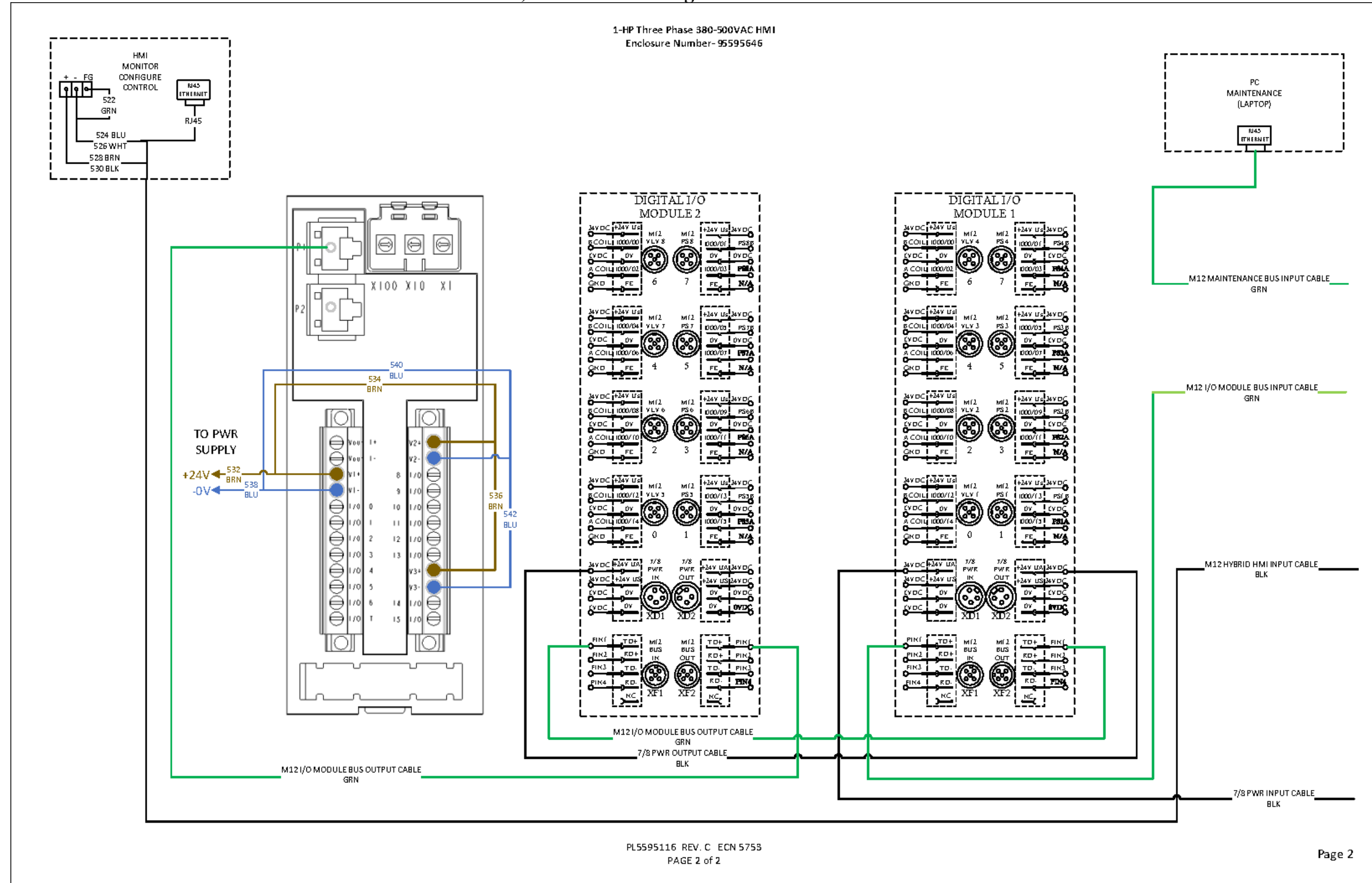

SECTION VI

MAINTENANCE (continued)

29. Three Phase 525-600VAC Machine Interface Enclosure, HMI Ethernet Page 1 of 2

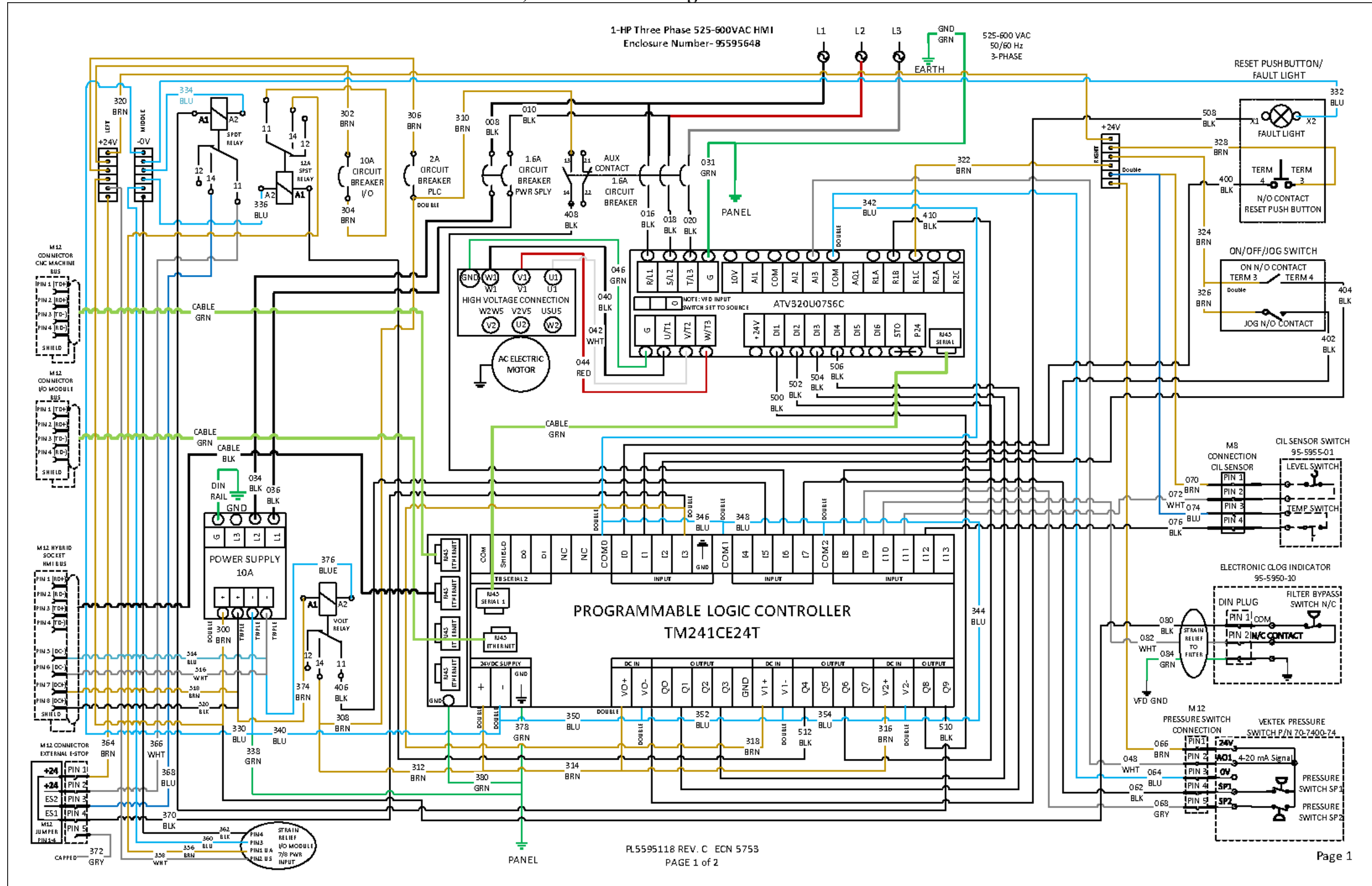

SECTION VI

MAINTENANCE (continued)

30. Three Phase 525-600VAC Machine Interface Enclosure, HMI Ethernet Page 2 of 2

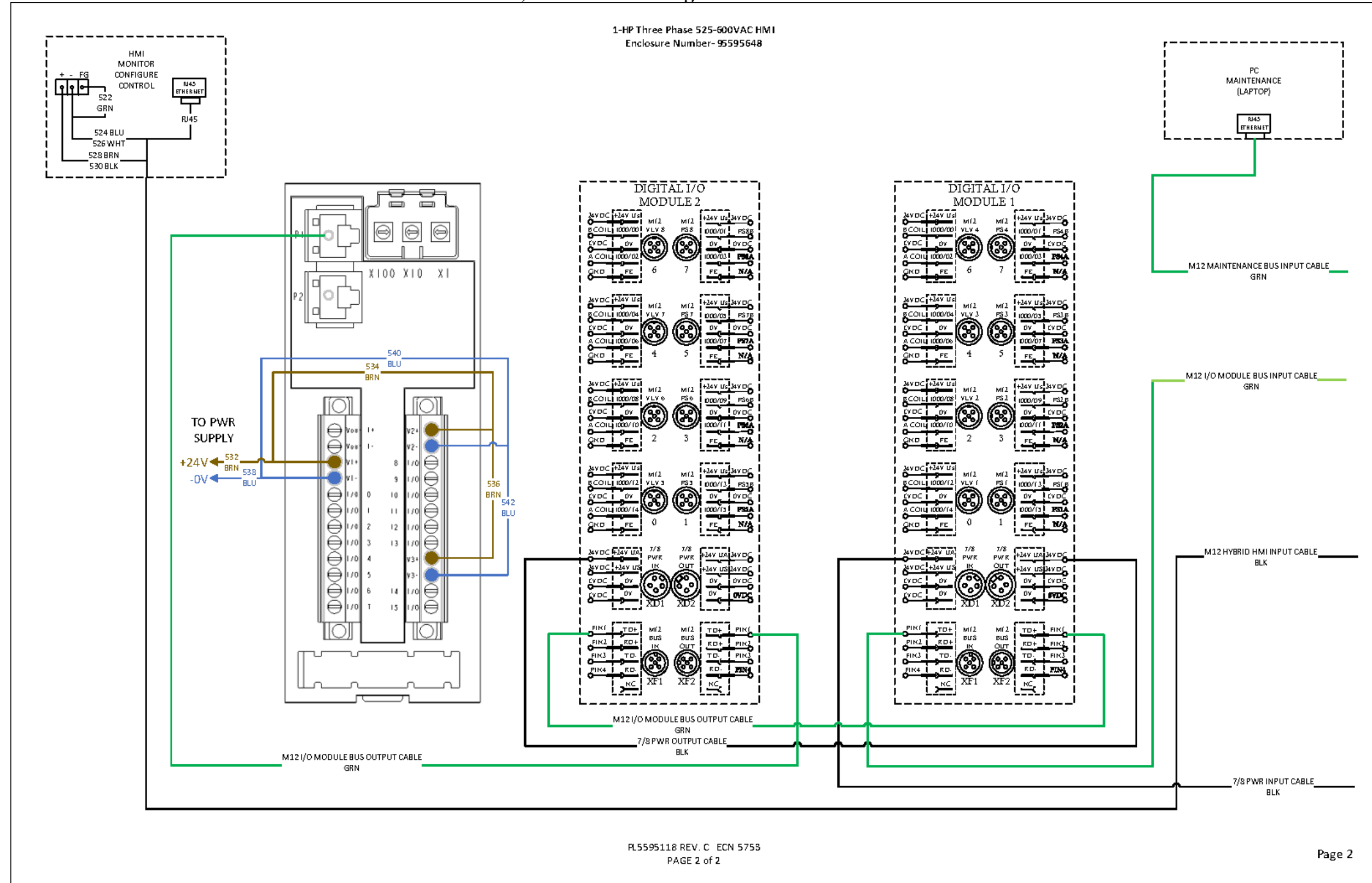

SECTION VI

MAINTENANCE (continued)

D. BASIC PUMP SCHEMATIC

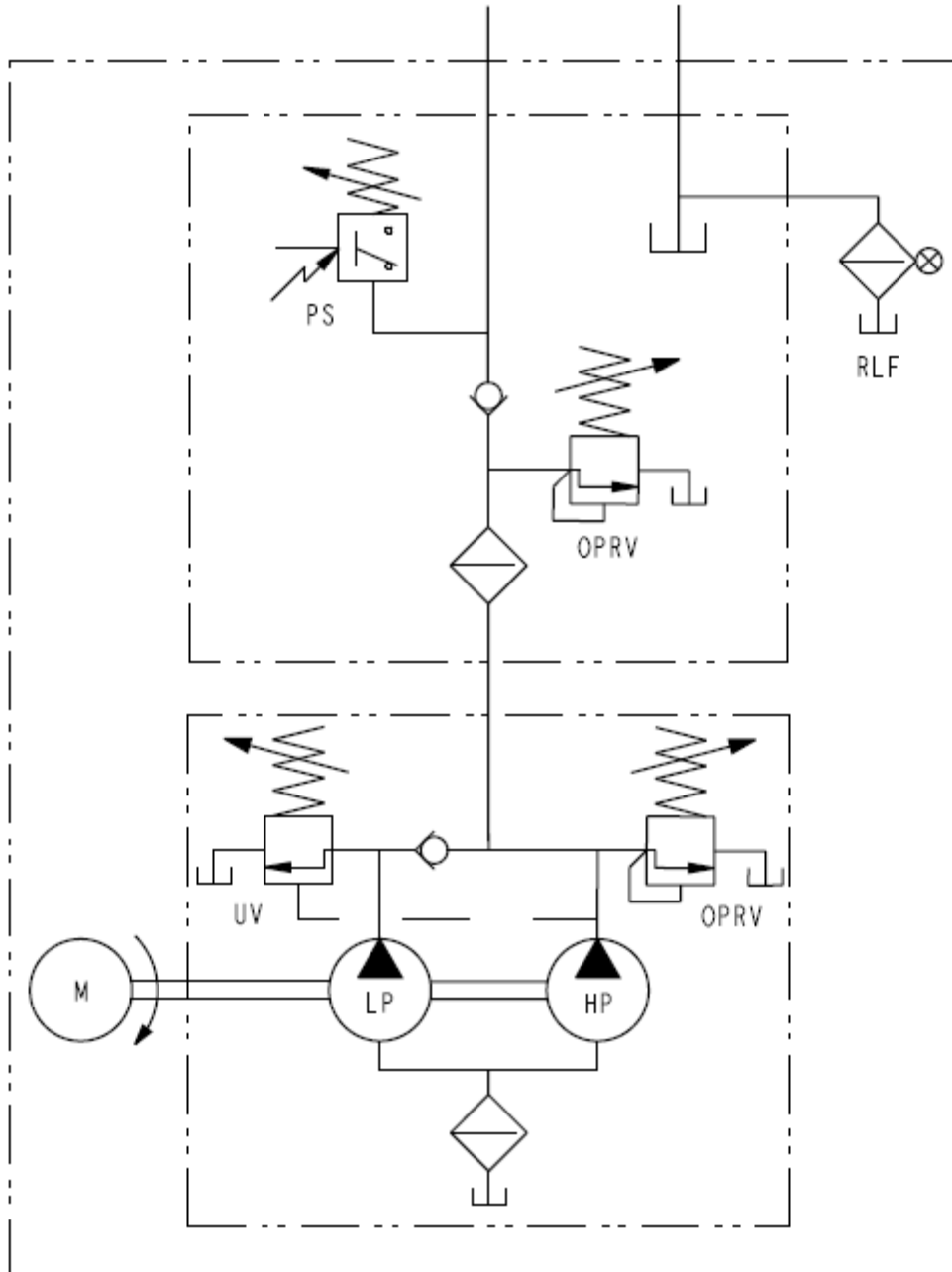

SECTION VII

TROUBLE SHOOTING

<u>Symptom</u>	<u>Cause</u>	<u>Solution</u>
Sporadic Cylinder Operation	1. Air in the Hydraulic System	1. See Section III Part C. for bleeding procedure.
Motor Will Not Start (Fault Light Illuminated and EPF1 Displayed on Variable Frequency Drive LCD)	<p>Prior to opening Control Enclosure Check Causes #1 and #2.</p> <p>1. Low Oil.</p> <p>2. Oil Over Temperature (with Optional Temp Sensor)</p> <p>3. Filter Bypass Switch Activated (With Optional Filter Bypass Switch)</p>	<p>All Faults Illuminating the Fault Light will require use of the Reset Procedure in Part D. of Section III</p> <p>1. Check Oil Level Using Sight Glass. Add Oil if level is below "Add Oil" or not visible in sight Glass. USE CAUTION DO NOT OVERFILL! OIL LEVEL COULD BE ABOVE SIGHT GLASS!</p> <p>2. Hold Hand Close to Reservoir. DO NOT TOUCH DIRECTLY AS SERIOUS INJURY COULD OCCUR IF A HIGH TEMPERATURE FAULT OCCURED. If reservoir is hot, allow to cool, and follow Reset Procedure</p> <p>3. If Oil Level is within range and reservoir is cool, change filter and reset fault.</p>
Motor Will Not Start (Fault Light Illuminated and OHF Displayed on Variable Frequency Drive LCD)	1. Drive Thermal Overload	1. Allow Pump to cool and follow reset procedure.
Motor Will Not Start (Fault Light Illuminated and Neither EPF1 or OHF Displayed on the Variable Frequency Drive LCD)	1. Other Variable Frequency Drive Fault	<p>1. See Appendix A or B for drive fault explanation.</p> <p>2. Consult factory.</p>
Motor Will Not Start (Fault Light Not Illuminated, Selector in ON or JOG position)	<p>1. No Power To Pump</p> <p>2. Circuit breaker tripped or Fuse Blown.</p>	<p>1. Ensure Proper electrical service is provided to pump. Consult a certified electrician if necessary.</p> <p>2. Remove Power from pump. Open Control Enclose and inspect circuit breakers for tripped condition. Reset breakers if necessary.</p>
Noisy Operation	<p>1. Air in System</p> <p>2. Clogged internal Suction Screen.</p>	<p>1. See Section III Part C. for bleeding procedure.</p> <p>2. See Section V for Cleaning Procedure.</p>

SECTION VII

TROUBLE SHOOTING (Continued)

<p>Pump Runs But will Not Pump Oil</p>	<ol style="list-style-type: none"> 1. Pump Not Primed 2. Control Valve Problem 3. Quick Coupling Not Fully Engaged or Damaged. 4. Pressure Relief Valve Out of Adjustment. 	<ol style="list-style-type: none"> 1. Consult factory for pump priming process. 2. Check Valve/Pendant Connection Block for 2 green lights near the bottom. If green lights not illuminated, check 24V power to Valve Pendant block, reset circuit breaker if needed. 2a. Turn pump to OFF position on Selector Switch. Toggle Pendant switch through all position and watch valve for associated indicators to illuminate. If #2 is completed and no indicators appear as switch is toggles, check valve wiring. If indicator(s) appear(s), check all other causes. 3. Remove Pressure from Circuit, fully engage couplers or replace as necessary. 4. Consult Factory for Adjustment.
<p>Pump Runs, Cylinders Extend/Retract, But Pump Will Not Build Pressure</p>	<ol style="list-style-type: none"> 1. Leak in Pressure Circuit 2. Pressure Relief Valve Out of Adjustment 	<ol style="list-style-type: none"> 1. Isolate and Operate Pump. When proper pump operation confirmed, examine circuit connected to pump for leaks. 2. Consult Factory for Adjustment.
<p>Pressure Does Not Hold (Pump Stops and Starts Frequently)</p>	<ol style="list-style-type: none"> 1. Leak in Pressure Circuit 2. Reset Point of Pressure Switch set too close to Set Point. 	<ol style="list-style-type: none"> 1. Isolate and Operate and Confirm operation. If frequent starting continues with pump isolated, move to cause #2 2. Reset point should be approximately 10% below Set Pressure. If Reset Point of pressure switch is set properly, pump may have internal leak. Consult factory.
<p>Motor Does Not Stop Automatically</p>	<ol style="list-style-type: none"> 1. Severe Leak in Pressure Circuit. 2. Pressure Switch Set Incorrectly 3. Pressure Switch Set Point set too high for overpressure Relief. 	<ol style="list-style-type: none"> 1. Isolate Pump and Confirm Operation. If pump continues to run continuously, move to Cause #2. 2. Set Pressure Switch less than or equal to 5000PSI. 3. Set Pressure Switch less than or equal to 5000PSI. If pump continues to run continuously, consult factory for adjustment.

If the procedures listed above do not remedy symptoms, contact factory at 1-800-992-0236.

SECTION VIII

WARRANTY AND RETURN INFORMATION

WARRANTY

Vektek warrants each VektorFlo® product to the original purchaser unless end user assignment is made at the time of purchase. Each device is warranted against defects in workmanship and materials for one year from the date of delivery.

This warranty is limited to the repair or replacement of any part or parts which are found by Vektek to be defective and does not cover ordinary wear and tear, abuse, misapplication, overloading, excessive flow rates, altered products or the use of improper fluids.

This warranty is the only warranty covering VektorFlo products. There are no other warranties covering VektorFlo products, either expressed or implied.

Vektek specifically disclaims any warranty of merchantability or fitness for a particular purpose.

When the question of warranty arises, the user must contact the factory for permission to return the merchandise. All returned merchandise must be addressed to a Return Authorization number and shipped to the address indicated on the RA.

RETURNS

All returns are subject to a progressive restocking fee. There is a \$25.00 minimum restocking fee on any return. All returns must be pre-authorized, please call for Return Authorization number. Any return not sent to a specific RA number will be treated as scrap. Transportation is to be prepaid and the evidence of delivery date furnished.

SECTION IX

Hydraulic Fluid SDS

Vektek Hydraulic Fluid
P/N 65-0010-01

ENGINEERING NOTICE
EN-6500_EN Revision H

Safety Data Sheet

According to OSHA HCS 2012 (29 CFR 1910.1200)



SECTION 1: Identification

Product Identifier	Megaflow® AW Hydraulic Oil	
Other means of identification	Phillips 66 Megaflow® AW Hydraulic Oil 22 Phillips 66 Megaflow® AW Hydraulic Oil 32 Phillips 66 Megaflow® AW Hydraulic Oil 46 Phillips 66 Megaflow® AW Hydraulic Oil 68 Phillips 66 Megaflow® AW Hydraulic Oil 100 Phillips 66 Megaflow® AW Hydraulic Oil 150 Phillips 66 Megaflow® AW Hydraulic Oil 220 Phillips 66 Megaflow® AW Hydraulic Oil 320	
SDS Number	LBPH814637	
Relevant identified uses	Hydraulic Fluid	
Uses advised against	All others	
24 Hour Emergency Phone Number	CHEMTREC 1-800-424-9300 CHEMTREC Mexico 01-800-681-9531	
Manufacturer/Supplier	SDS Information	Customer Service
Phillips 66 Lubricants P.O. Box 4428 Houston, TX 77210	Phone: 800-762-0942 Email: SDS@P66.com URL: www.Phillips66.com	U.S.: 800-368-7128 or International: 1-832-765-2500 Technical Information 1-877-445-9198

SECTION 2: Hazard identification

Classified Hazards	Hazards Not Otherwise Classified (HNOC)
This material is not hazardous under the criteria of the Federal OSHA Hazard Communication Standard 29CFR 1910.1200.	PHNOC: None known HHNOC: None known

Label Elements
No classified hazards

SECTION 3: Composition/information on ingredients

Chemical Name	CASRN	Concentration ¹
Distillates, petroleum, hydrotreated heavy paraffinic	64742-54-7	>99

¹ All concentrations are percent by weight unless ingredient is a gas. Gas concentrations are in percent by volume.

SECTION 4: First aid measures

Eye Contact: If irritation or redness develops from exposure, flush eyes with clean water. If symptoms persist, seek medical attention.

Skin Contact: First aid is not normally required. However, it is good practice to wash any chemical from the skin. If product is injected into or under the skin, or into any part of the body, regardless of the appearance of the wound or its size, the individual should be evaluated immediately by a physician. (see Note to Physician)

Inhalation: First aid is not normally required. If breathing difficulties develop, move victim away from source of exposure and into fresh air in a position comfortable for breathing. Seek immediate medical attention.

Ingestion: First aid is not normally required; however, if swallowed and symptoms develop, seek medical attention.

SECTION IX Hydraulic Fluid SDS (Continued)

LBPH814637 - Megaflo®AW Hydraulic Oil
Issue Date: 28-Jun-2016

Page 2/6
Status: FINAL

Most important symptoms and effects, both acute and delayed: Inhalation of oil mists or vapors generated at elevated temperatures may cause respiratory irritation. Accidental ingestion can result in minor irritation of the digestive tract, nausea and diarrhea.

Notes to Physician: Acute aspirations of large amounts of oil-laden material may produce a serious aspiration pneumonia. Patients who aspirate these oils should be followed for the development of long-term sequelae. Inhalation exposure to oil mists below current workplace exposure limits is unlikely to cause pulmonary abnormalities. When using high-pressure equipment, injection of product under the skin can occur. In this case, the casualty should be sent immediately to the hospital. Do not wait for symptoms to develop. High-pressure hydrocarbon injection injuries may produce substantial necrosis of underlying tissue despite an innocuous appearing external wound. These injuries often require extensive emergency surgical debridement and all injuries should be evaluated by a specialist in order to assess the extent of injury. Early surgical treatment within the first few hours may significantly reduce the ultimate extent of injury.

SECTION 5: Firefighting measures

NFPA 704 Hazard Class

Health: 0 **Flammability:** 1 **Instability:** 0



0 (Minimal)
1 (Slight)
2 (Moderate)
3 (Serious)
4 (Severe)

Extinguishing Media: Dry chemical, carbon dioxide, foam, or water spray is recommended. Water or foam may cause frothing of materials heated above 212°F / 100°C. Carbon dioxide can displace oxygen. Use caution when applying carbon dioxide in confined spaces. Simultaneous use of foam and water on the same surface is to be avoided as water destroys the foam.

Specific hazards arising from the chemical

Unusual Fire & Explosion Hazards: This material may burn, but will not ignite readily. If container is not properly cooled, it can rupture in the heat of a fire.

Hazardous Combustion Products: Combustion may yield smoke, carbon monoxide, and other products of incomplete combustion. Oxides of sulfur, nitrogen or phosphorus may also be formed.

Special protective actions for firefighters: For fires beyond the initial stage, emergency responders in the immediate hazard area should wear protective clothing. When the potential chemical hazard is unknown, in enclosed or confined spaces, a self contained breathing apparatus should be worn. In addition, wear other appropriate protective equipment as conditions warrant (see Section 8).

Isolate the hazard area and deny entry to unnecessary and unprotected personnel. Stop spill/release if it can be done safely. Move undamaged containers from immediate hazard area if it can be done safely. Water spray may be useful in minimizing or dispersing vapors and to protect personnel. Cool equipment exposed to fire with water, if it can be done safely. Avoid spreading burning liquid with water used for cooling purposes.

See Section 9 for Flammable Properties including Flash Point and Flammable (Explosive) Limits

SECTION 6: Accidental release measures

Personal precautions, protective equipment and emergency procedures: This material may burn, but will not ignite readily. Keep all sources of ignition away from spill/release. Stay upwind and away from spill/release. Avoid direct contact with material. For large spillages, notify persons down wind of the spill/release, isolate immediate hazard area and keep unauthorized personnel out. Wear appropriate protective equipment, including respiratory protection, as conditions warrant (see Section 8). See Sections 2 and 7 for additional information on hazards and precautionary measures.

SECTION IX

Hydraulic Fluid SDS (Continued)

LBP814637 - Megaflow® AW Hydraulic Oil
Issue Date: 28-Jun-2016

Page 3/6
Status: FINAL

Environmental Precautions: Stop and contain spill/release if it can be done safely. Prevent spilled material from entering sewers, storm drains, other unauthorized drainage systems, and natural waterways. Use water sparingly to minimize environmental contamination and reduce disposal requirements. If spill occurs on water notify appropriate authorities and advise shipping of any hazard. Spills into or upon navigable waters, the contiguous zone, or adjoining shorelines that cause a sheen or discoloration on the surface of the water, may require notification of the National Response Center (phone number 800-424-8802).

Methods and material for containment and cleaning up: Notify relevant authorities in accordance with all applicable regulations. Immediate cleanup of any spill is recommended. Dike far ahead of spill for later recovery or disposal. Absorb spill with inert material such as sand or vermiculite, and place in suitable container for disposal. If spilled on water remove with appropriate methods (e.g. skimming, booms or absorbents). In case of soil contamination, remove contaminated soil for remediation or disposal, in accordance with local regulations.

Recommended measures are based on the most likely spillage scenarios for this material; however local conditions and regulations may influence or limit the choice of appropriate actions to be taken. See Section 13 for information on appropriate disposal.

SECTION 7: Handling and storage

Precautions for safe handling: Keep away from flames and hot surfaces. Wash thoroughly after handling. Use good personal hygiene practices and wear appropriate personal protective equipment (see section 8). Spills will produce very slippery surfaces. High pressure injection of hydrocarbon fuels, hydraulic oils or greases under the skin may have serious consequences even though no symptoms or injury may be apparent. This can happen accidentally when using high pressure equipment such as high pressure grease guns, fuel injection apparatus or from pinhole leaks in tubing of high pressure hydraulic oil equipment.

Do not enter confined spaces such as tanks or pits without following proper entry procedures such as ASTM D-4276 and 29CFR 1910.146. Do not wear contaminated clothing or shoes.

Conditions for safe storage: Keep container(s) tightly closed and properly labeled. Use and store this material in cool, dry, well-ventilated area away from heat and all sources of ignition. Store only in approved containers. Keep away from any incompatible material (see Section 10). Protect container(s) against physical damage.

"Empty" containers retain residue and may be dangerous. Do not pressurize, cut, weld, braze, solder, drill, grind, or expose such containers to heat, flame, sparks, or other sources of ignition. They may explode and cause injury or death. "Empty" drums should be completely drained, properly bunged, and promptly shipped to the supplier or a drum reconditioner. All containers should be disposed of in an environmentally safe manner and in accordance with governmental regulations. Before working on or in tanks which contain or have contained this material, refer to OSHA regulations, ANSI Z49.1, and other references pertaining to cleaning, repairing, welding, or other contemplated operations.

SECTION 8: Exposure controls/personal protection

Chemical Name	ACGIH	OSHA	Phillips 66
Distillates, petroleum, hydrotreated heavy paraffinic	---	---	TWA: 5 mg/m ³ STEL: 10 mg/m ³ as Oil Mist, if Generated

Note: State, local or other agencies or advisory groups may have established more stringent limits. Consult an industrial hygienist or similar professional, or your local agencies, for further information.

Engineering controls: If current ventilation practices are not adequate to maintain airborne concentrations below the established exposure limits, additional engineering controls may be required.

Eye/Face Protection: The use of eye/face protection is not normally required; however, good industrial hygiene practice suggests the use of eye protection that meets or exceeds ANSI Z.87.1 whenever working with chemicals.

Skin/Hand Protection: The use of skin protection is not normally required; however, good industrial hygiene practice suggests the use of gloves or other appropriate skin protection whenever working with chemicals. Suggested protective materials: Nitrile

Respiratory Protection: Where there is potential for airborne exposure above the exposure limit a NIOSH certified air purifying respirator equipped with R or P95 filters may be used.

A respiratory protection program that meets or is equivalent to OSHA 29 CFR 1910.134 and ANSI Z88.2 should be followed whenever workplace conditions warrant a respirator's use. Air purifying respirators provide limited protection and cannot be used in atmospheres that exceed the maximum use concentration (as directed by regulation or the manufacturer's instructions), in oxygen deficient (less than 19.5 percent oxygen) situations, or under conditions that are immediately dangerous to life and health (IDLH).

SECTION IX Hydraulic Fluid SDS (Continued)

LBPH814637 - Megaflow® AW Hydraulic Oil
Issue Date: 28-Jun-2016

Page 4/6
Status: **FINAL**

Suggestions provided in this section for exposure control and specific types of protective equipment are based on readily available information. Users should consult with the specific manufacturer to confirm the performance of their protective equipment. Specific situations may require consultation with industrial hygiene, safety, or engineering professionals.

SECTION 9: Physical and chemical properties

Note: Unless otherwise stated, values are determined at 20°C (68°F) and 760 mm Hg (1 atm). Data represent typical values and are not intended to be specifications.

Appearance: Amber, Transparent	Flash Point: > 302 °F / > 150 °C (ASTM D93)
Physical Form: Liquid	Test Method: Pensky-Martens Closed Cup (PMCC), ASTM D93, EPA 1010
Odor: Petroleum	Initial Boiling Point/Range: No data
Odor Threshold: No data	Vapor Pressure: <1 mm Hg
pH: Not applicable	Partition Coefficient (n-octanol/water) (Kow): No data
Vapor Density (air=1): >1	Melting/Freezing Point: No data
Upper Explosive Limits (vol % in air): No data	Auto-ignition Temperature: No data
Lower Explosive Limits (vol % in air): No data	Decomposition Temperature: No data
Evaporation Rate (nBuAc=1): No data	Specific Gravity (water=1): 0.85-0.89 @ 60°F (15.6°C)
Particle Size: Not applicable	Bulk Density: No data
Percent Volatile: No data	Viscosity: 4.0 - 25 cSt @ 100°C; 21 - 345 cSt @ 40°C
Flammability (solid, gas): Not applicable	Pour Point: < 10 °F / < -12 °C
Solubility in Water: Negligible	

SECTION 10: Stability and reactivity

Reactivity: Not chemically reactive.

Chemical stability: Stable under normal ambient and anticipated conditions of use.

Possibility of hazardous reactions: Hazardous reactions not anticipated.

Conditions to avoid: Extended exposure to high temperatures can cause decomposition. Avoid all possible sources of ignition.

Incompatible materials: Avoid contact with strong oxidizing agents and strong reducing agents.

Hazardous decomposition products: Not anticipated under normal conditions of use.

SECTION 11: Toxicological information

Information on Toxicological Effects

Substance / Mixture

Acute Toxicity	Hazard	Additional Information	LC50/LD50 Data
Inhalation	Unlikely to be harmful		>5 mg/L (mist, estimated)
Dermal	Unlikely to be harmful		> 2 g/kg (estimated)
Oral	Unlikely to be harmful		> 5 g/kg (estimated)

Aspiration Hazard: Not expected to be an aspiration hazard.

Skin Corrosion/Irritation: Not expected to be irritating.

Serious Eye Damage/Irritation: Not expected to be irritating.

Skin Sensitization: No information available on the mixture, however none of the components have been classified for skin sensitization (or are below the concentration threshold for classification).

Respiratory Sensitization: No information available.

Specific Target Organ Toxicity (Single Exposure): No information available on the mixture, however none of the components have been classified for target organ toxicity (or are below the concentration threshold for classification).

SECTION IX

Hydraulic Fluid SDS (Continued)

LBPH814637 - Megaflow® AW Hydraulic Oil
Issue Date: 28-Jun-2016

Page 5/6
Status: FINAL

Specific Target Organ Toxicity (Repeated Exposure): No information available on the mixture, however none of the components have been classified for target organ toxicity (or are below the concentration threshold for classification).

Carcinogenicity: No information available on the mixture, however none of the components have been classified for carcinogenicity (or are below the concentration threshold for classification).

Germ Cell Mutagenicity: No information available on the mixture, however none of the components have been classified for germ cell mutagenicity (or are below the concentration threshold for classification).

Reproductive Toxicity: No information available on the mixture, however none of the components have been classified for reproductive toxicity (or are below the concentration threshold for classification).

Information on Toxicological Effects of Components

Distillates, petroleum, hydrotreated heavy paraffinic

Carcinogenicity: This oil has been highly refined by a variety of processes to reduce aromatics and improve performance characteristics. It meets the IP-346 criteria of less than 3 percent PAH's and is not considered a carcinogen by the International Agency for Research on Cancer.

SECTION 12: Ecological information

GHS Classification: **No classified hazards**

Toxicity: All acute aquatic toxicity studies on samples of lubricant base oils show acute toxicity values greater than 100 mg/L for invertebrates, algae and fish. These tests were carried out on water accommodated fractions and the results are consistent with the predicted aquatic toxicity of these substances based on their hydrocarbon compositions.

Persistence and Degradability: The hydrocarbons in this material are not readily biodegradable, but since they can be degraded by microorganisms, they are regarded as inherently biodegradable.

Bioaccumulative Potential: Log Kow values measured for the hydrocarbon components of this material are greater than 5.3, and therefore regarded as having the potential to bioaccumulate. In practice, metabolic processes may reduce bioconcentration.

Mobility in Soil: Volatilization to air is not expected to be a significant fate process due to the low vapor pressure of this material. In water, base oils will float and spread over the surface at a rate dependent upon viscosity. There will be significant removal of hydrocarbons from the water by sediment adsorption. In soil and sediment, hydrocarbon components will show low mobility with adsorption to sediments being the predominant physical process. The main fate process is expected to be slow biodegradation of the hydrocarbon constituents in soil and sediment.

Other adverse effects: None anticipated.

SECTION 13: Disposal considerations

The generator of a waste is always responsible for making proper hazardous waste determinations and needs to consider state and local requirements in addition to federal regulations. This material, if discarded as produced, would not be a federally regulated RCRA "listed" hazardous waste and is not believed to exhibit characteristics of hazardous waste. See Sections 7 and 8 for information on handling, storage and personal protection and Section 9 for physical/chemical properties. It is possible that the material as produced contains constituents which are not required to be listed in the SDS but could affect the hazardous waste determination. Additionally, use which results in chemical or physical change of this material could subject it to regulation as a hazardous waste. This material under most intended uses would become "Used Oil" due to contamination by physical or chemical impurities. Whenever possible, Recycle used oil in accordance with applicable federal and state or local regulations. Container contents should be completely used and containers should be emptied prior to discard.

SECTION 14: Transport information

U.S. Department of Transportation (DOT)

UN Number: Not regulated

UN proper shipping name: None

Transport hazard class(es): None

Packing Group: None

Environmental Hazards: This product does not meet the DOT/UN/MDG/IMO criteria of a marine pollutant

SECTION IX Hydraulic Fluid SDS (Continued)

LBP814637 - Megaflow® AW Hydraulic Oil
Issue Date: 28-Jun-2016

Page 6/6
Status: **FINAL**

Special precautions for user: If shipped by land in a packaging having a capacity of 3,500 gallons or more, the provisions of 49 CFR, Part 130 apply. (Contains oil)

Transport in bulk according to Annex II of MARPOL 73/78 and the IBC Code: Not applicable

SECTION 15: Regulatory information

CERCLA/SARA - Section 302 Extremely Hazardous Substances and TPQs (in pounds):

This material does not contain any chemicals subject to the reporting requirements of SARA 302 and 40 CFR 372.

CERCLA/SARA - Section 311/312 (Title III Hazard Categories)

Acute Health Hazard:	No
Chronic Health Hazard:	No
Fire Hazard:	No
Pressure Hazard:	No
Reactive Hazard:	No

CERCLA/SARA - Section 313 and 40 CFR 372:

This material does not contain any chemicals subject to the reporting requirements of SARA 313 and 40 CFR 372.

EPA (CERCLA) Reportable Quantity (in pounds):

This material does not contain any chemicals with CERCLA Reportable Quantities.

California Proposition 65:

This material does not contain any chemicals which are known to the State of California to cause cancer, birth defects or other reproductive harm at concentrations that trigger the warning requirements of California Proposition 65.

International Hazard Classification

Canada:

This product has been classified in accordance with the hazard criteria of the Hazardous Products Regulations (SOR/2015-17) and the SDS contains all the information required by the Regulations.

International Inventories

All components are either listed on the US TSCA Inventory, or are not regulated under TSCA.

All components are either on the DSL, or are exempt from DSL listing requirements.

U.S. Export Control Classification Number: EAR99

SECTION 16: Other information

Issue Date:	Previous Issue Date:	SDS Number	Status:
28-Jun-2016	23-Jun-2016	LBP814637	FINAL

Revised Sections or Basis for Revision:

New SDS

Guide to Abbreviations:

ACGIH = American Conference of Governmental Industrial Hygienists; CASRN = Chemical Abstracts Service Registry Number; CEILING = Ceiling Limit (15 minutes); CERCLA = The Comprehensive Environmental Response, Compensation, and Liability Act; EPA = Environmental Protection Agency; GHS = Globally Harmonized System; IARC = International Agency for Research on Cancer; INSHT = National Institute for Health and Safety at Work; IOPC = International Oil Pollution Compensation; LEL = Lower Explosive Limit; NE = Not Established; NFPA = National Fire Protection Association; NTP = National Toxicology Program; OSHA = Occupational Safety and Health Administration; PEL = Permissible Exposure Limit (OSHA); SARA = Superfund Amendments and Reauthorization Act; STEL = Short Term Exposure Limit (15 minutes); TLV = Threshold Limit Value (ACGIH); TWA = Time Weighted Average (8 hours); UEL = Upper Explosive Limit; WHMIS = Worker Hazardous Materials Information System (Canada)

Disclaimer of Expressed and Implied Warranties:

The information presented in this Safety Data Sheet is based on data believed to be accurate as of the date this Safety Data Sheet was prepared. HOWEVER, NO WARRANTY OF MERCHANTABILITY, FITNESS FOR ANY PARTICULAR PURPOSE, OR ANY OTHER WARRANTY IS EXPRESSED OR IS TO BE IMPLIED REGARDING THE ACCURACY OR COMPLETENESS OF THE INFORMATION PROVIDED ABOVE. THE RESULTS TO BE OBTAINED FROM THE USE OF THIS INFORMATION OR THE PRODUCT, THE SAFETY OF THIS PRODUCT, OR THE HAZARDS RELATED TO ITS USE. No responsibility is assumed for any damage or injury resulting from abnormal use or from any failure to adhere to recommended practices. The information provided above, and the product, are furnished on the condition that the person receiving them shall make their own determination as to the suitability of the product for their particular purpose and on the condition that they assume the risk of their use. In addition, no authorization is given nor implied to practice any patented invention without a license.

Appendix A

ATV12 Variable Frequency Drive Diagnostics and Trouble Shooting

Model No.

ATV12H075F1, 1-PH, 100-120 VAC
ATV12H075M2, 1-PH, 200-240 VAC
ATV12H075M3, 3-PH, 200-240 VAC

Diagnostics and Troubleshooting

Drive does not start, no error code displayed

- If the display does not light up, check the power supply to the drive (ground and input phases connection, see page 20).
- The assignment of the "Fast stop" or "Freewheel" functions will prevent the drive starting if the corresponding logic inputs are not powered up. The ATV12 then displays **n S t** in freewheel stop and **F S t** in fast stop, it will display **r d y** on freewheel stop. This is normal since these functions are active at zero so that the drive will be stopped if there is a wire break. Assignment of LI to be checked in **C D n F / F U L L / F U n - / S t t** - menu.
- Make sure that the run command input(s) is activated in accordance with the selected control mode (parameters Type of control **t C C** page 48 and 2 wire type control **t C t** page 51, in **C D n F / F U L L / I - D** - menu).
- If the reference channel or command channel is assigned to Modbus, when the power supply is connected, the drive displays "**n S t**" freewheel and remain in stop mode until the communication bus sends a command.
- In factory setting "RUN" button is inactive. Adjust parameters Reference channel 1 **F r 1** page 62 and Command channel 1 **C d 1** page 63 to control the drive locally (**C D n F / F U L L / C t L** - menu). See How to control the drive locally page 46.

Fault detection codes that cannot be cleared automatically

The cause of the detected fault must be removed before clearing by turning off and then on.

S D F and **t n F** faults can also be cleared remotely by means of a logic input (parameter Detected fault reset assignment **r S F** page 91 in **C D n F / F U L L / F L t** - menu).

Code	Name	Possible causes	Remedy
C r F 1	Precharge	<ul style="list-style-type: none"> • Charging relay control fault or charging resistor damaged 	<ul style="list-style-type: none"> • Turn the drive off and then back on again • Check the connections • Check the stability of the main supply • Contact your local Schneider Electric representative
I n F 1	Unknown drive rating	<ul style="list-style-type: none"> • The power card is different from the card stored 	<ul style="list-style-type: none"> • Contact your local Schneider Electric representative
I n F 2	Unknown or incompatible power board	<ul style="list-style-type: none"> • The power card is incompatible with the control card 	<ul style="list-style-type: none"> • Contact your local Schneider Electric representative
I n F 3	Internal serial link	<ul style="list-style-type: none"> • Communication interruption between the internal cards 	<ul style="list-style-type: none"> • Contact your local Schneider Electric representative
I n F 4	Invalid industrialization zone	<ul style="list-style-type: none"> • Inconsistent internal data 	<ul style="list-style-type: none"> • Contact your local Schneider Electric representative
I n F 9	Current measurement circuit	<ul style="list-style-type: none"> • Current measurement is not correct due to hardware circuit 	<ul style="list-style-type: none"> • Contact your local Schneider Electric representative
- - -	Problem of application Firmware	<ul style="list-style-type: none"> • Invalid application firmware update using the Multi-Loader tool 	<ul style="list-style-type: none"> • Flash again the application firmware of the product
I n F b	Internal thermal sensor detected fault	<ul style="list-style-type: none"> • The drive temperature sensor is not operating correctly • The drive is in short circuit or open 	<ul style="list-style-type: none"> • Contact your local Schneider Electric representative
I n F E	Internal CPU	<ul style="list-style-type: none"> • Internal microprocessor 	<ul style="list-style-type: none"> • Turn the drive off and then back on again • Contact local Schneider Electric representative

Diagnostics and Troubleshooting

Fault detection codes that cannot be cleared automatically (continued)

Code	Name	Possible causes	Remedy
<i>O C F</i>	Overcurrent	<ul style="list-style-type: none"> Parameters in the Motor control menu <i>d r C</i> - page 57 are not correct Inertia or load too high Mechanical locking 	<ul style="list-style-type: none"> Check the parameters Check the size of the motor/drive/load Check the state of the mechanism Connect line chokes Reduce the Switching frequency <i>S F r</i> page 59 Check the ground connection of drive, motor cable and motor insulation.
<i>S C F 1</i>	Motor short circuit	<ul style="list-style-type: none"> Short-circuit or grounding at the drive output Ground fault during running status Commutation of motors during running status Significant current leakage to ground if several motors are connected in parallel 	<ul style="list-style-type: none"> Check the cables connecting the drive to the motor, and the motor insulation Connect motor chokes
<i>S C F 3</i>	Ground short circuit		
<i>S C F 4</i>	IGBT short circuit	<ul style="list-style-type: none"> Internal power component short circuit detected at power-on 	<ul style="list-style-type: none"> Contact your local Schneider Electric representative
<i>S O F</i>	Overspeed	<ul style="list-style-type: none"> Instability Overspeed associated with the inertia of the application 	<ul style="list-style-type: none"> Check the motor Overspeed is 10% more than Maximum frequency <i>£ F r</i> page 57 so adjust this parameter if necessary Add a braking resistor Check the size of the motor/drive/load Check parameters of the speed loop (gain and stability)
<i>£ n F</i>	Auto-tuning	<ul style="list-style-type: none"> Motor not connected to the drive One motor phase loss Special motor Motor is rotating (being driven by the load, for example) 	<ul style="list-style-type: none"> Check that the motor/drive are compatible Check that the motor is present during auto-tuning If an output contactor is being used, close it during auto-tuning Check that the motor is completely stopped

Diagnosics and Troubleshooting

Fault detection codes that can be cleared with the automatic restart function, after the cause has disappeared

These detected faults can also be cleared by turning on and off or remotely by means of a logic input (parameter *Detected fault reset assignment* [r 5 F](#) page [91](#)).

Code	Name	Possible causes	Remedy
L F F 1	AI current lost fault	Detection if: <ul style="list-style-type: none"> Analog Input AI1 is configured as current AI1 current scaling parameter of 0% L r L 1 page 52 is greater than 3 mA Analog input current is lower than 2 mA 	<ul style="list-style-type: none"> Check the terminal connection
D b F	Overbraking	<ul style="list-style-type: none"> Braking too sudden or driving load too high 	<ul style="list-style-type: none"> Increase the deceleration time Install a module unit with a braking resistor if necessary Check the line supply voltage, to be sure that it is under the maximum acceptable (20% over maximum line supply during run status)
D H F	Drive overheat	<ul style="list-style-type: none"> Drive temperature too high 	<ul style="list-style-type: none"> Check the motor load, the drive ventilation and the ambient temperature. Wait for the drive to cool down before restarting. See Mounting and temperature conditions page 13.
D L C	Process overload	<ul style="list-style-type: none"> Process overload 	<ul style="list-style-type: none"> Check the process and the parameters of the drive to be in phase
D L F	Motor overload	<ul style="list-style-type: none"> Triggered by excessive motor current 	<ul style="list-style-type: none"> Check the setting of the motor thermal protection, check the motor load.
D P F 1	1 output phase loss	<ul style="list-style-type: none"> Loss of one phase at drive output 	<ul style="list-style-type: none"> Check the connections from the drive to the motor In case of using downstream contactor, check the right connection, cable and contactor
D P F 2	3 output phase loss	<ul style="list-style-type: none"> Motor not connected Motor power too low, below 6% of the drive nominal current Output contactor open Instantaneous instability in the motor current 	<ul style="list-style-type: none"> Check the connections from the drive to the motor Test on a low-power motor or without a motor: In factory settings mode, motor phase loss detection is active Output Phase loss detection D P L page 94 = y E 5. To check the drive in a test or maintenance environment, without having to use a motor with the same rating as the drive, deactivate motor phase loss detection Output Phase loss detection D P L = n 0 Check and optimize the following parameters: IR compensation (law U/F) U F r page 58, Rated motor voltage U n 5 page 57 and Rated motor current n C r page 57 and perform an Auto-tuning t U n page 60.
D S F	Main overvoltage	<ul style="list-style-type: none"> Line voltage too high: <ul style="list-style-type: none"> At drive power-on only, the supply is 10% over the maximum acceptable voltage level Power with no run order, 20% over the maximum line supply Disturbed line supply 	<ul style="list-style-type: none"> Turn Off the Drive. Check and adjust the line voltage. After line come back to nominal voltage (within tolerance) do power On. If intermittent D S F code appear, set Relay R1 to F L t and it can be connected to upstream protection to avoid overvoltage in the drive. In this case L D 1 can be used for others drive status see page 53

Diagnostics and Troubleshooting

Fault detection codes that can be cleared with the automatic restart function, after the cause has disappeared (continued)

Code	Name	Possible causes	Remedy
PHF	Input phase loss	<ul style="list-style-type: none"> • Drive incorrectly supplied or a fuse blown • Failure of one phase • 3-phase ATV12 used on a 1-phase line supply • Unbalanced load • This protection only operates with the drive on load 	<ul style="list-style-type: none"> • Check the power connection and the fuses. • Use a 3-phase line supply. • Disable the fault by setting Input Phase loss detection IPL page 94 = 0.
SCF5	Load short circuit	<ul style="list-style-type: none"> • Short-circuit at drive output • Short circuit detection at the run order or DC injection order if parameter IGBT test S t r t page 95 is set to YES 	<ul style="list-style-type: none"> • Check the cables connecting the drive to the motor, and the motor's insulation
SLF1	Modbus communication	<ul style="list-style-type: none"> • Interruption in communication on the Modbus network 	<ul style="list-style-type: none"> • Check the connections of communication bus. • Check the time-out (Modbus time out t t D parameter page 98) • Refer to the Modbus user manual
SLF2	SoMove communication	<ul style="list-style-type: none"> • Communication interruption with SoMove 	<ul style="list-style-type: none"> • Check the SoMove connecting cable. • Check the time-out
SLF3	HMI communication	<ul style="list-style-type: none"> • Communication interruption with the external display terminal 	<ul style="list-style-type: none"> • Check the terminal connection
SPIF	PI Feedback detected fault	<ul style="list-style-type: none"> • PID feedback below lower limit 	<ul style="list-style-type: none"> • Check the PID function feedback • Check the PI feedback supervision threshold L P I and time delay t P I, page 76.
ULF	Process underload fault	<ul style="list-style-type: none"> • Process underload • Motor current below the Application Underload threshold L U L parameter page 55 during a period set by Application underload time delay U L t parameter page 55 to protect the application. 	<ul style="list-style-type: none"> • Check the process and the parameters of the drive to be in phase
t JF	IGBT overheat	<ul style="list-style-type: none"> • Drive overheated • IGBT internal temperature is too high according to ambient temperature and load 	<ul style="list-style-type: none"> • Check the size of the load/motor/drive. • Reduce the Switching frequency S F r page 59. • Wait for the drive to cool before restarting
EPFI	External detected fault by logic input	<ul style="list-style-type: none"> • Event triggered by an external device, depending on user 	<ul style="list-style-type: none"> • Check the device which caused the trip and reset.

Diagnostics and Troubleshooting

Faults codes that will be cleared as soon as their causes disappear

The USF fault can be cleared remotely by means of a logic input (parameter Detected fault reset assignment *r 5 F* page 91).

Code	Name	Possible causes	Remedy
<i>C F F</i>	Incorrect configuration	<ul style="list-style-type: none"> HMI block replaced by an HMI block configured on a drive with a different rating The current configuration of customer parameters is inconsistent 	<ul style="list-style-type: none"> Return to factory settings or retrieve the backup configuration, if it is valid. If the fault remains after reverting to the factory settings, contact your local Schneider Electric representative
<i>C F I</i> (1)	Invalid configuration	<ul style="list-style-type: none"> Invalid configuration The configuration loaded in the drive via the bus or communication network is inconsistent. The configuration upload has been interrupted or is not fully finished. 	<ul style="list-style-type: none"> Check the configuration loaded previously. Load a compatible configuration
<i>C F I 2</i>	Download invalid configuration	<ul style="list-style-type: none"> Interruption of download operation with Loader or SoMove 	<ul style="list-style-type: none"> Check connection with Loader or SoMove. To reset the default re-start the download operation or restore the factory setting
<i>U S F</i>	Undervoltage	<ul style="list-style-type: none"> Line supply too low Transient voltage dip 	<ul style="list-style-type: none"> Check the voltage and the parameters of Undervoltage Phase Loss Menu <i>U S b</i> - page 95.

(1) When the CFI is present in the past fault menu, it means the configuration has been interrupted or is not fully finished.

HMI block changed

When an HMI block is replaced by an HMI block configured on a drive with a different rating, the drive locks in Incorrect configuration *C F F* fault mode on power-up. If the card has been deliberately changed, the fault can be cleared by returning to factory setting.

Diagnostics and Troubleshooting

Fault detection codes displayed on the remote display terminal

Code	Name	Description
<i>In It</i>	On initializing itself	<ul style="list-style-type: none"> • Micro controller initializing • Communication configuration search
<i>CDN. E</i> (1)	Communication error	<ul style="list-style-type: none"> • It has 50ms time-out error. • This message is shown after 220 retry attempts.
<i>A-17</i> (1)	Key alarm	<ul style="list-style-type: none"> • Key has been pressed consecutively for more than 10 seconds. • Membrane switch disconnected. • Keypad woken up while a key is being pressed.
<i>CLR</i> (1)	Confirm Fault reset	<ul style="list-style-type: none"> • This message appears if the STOP key is pressed when there is a keypad fault.
<i>DEU. E</i> (1)	Drive mismatch	<ul style="list-style-type: none"> • Drive type (brand) did not match with keypad type (brand)
<i>CDN. E</i> (1)	ROM abnormality	<ul style="list-style-type: none"> • Keypad ROM abnormality detected by the checksum calculation.
<i>RAM. E</i> (1)	RAM abnormality	<ul style="list-style-type: none"> • Keypad RAM abnormality detected.
<i>CPU. E</i> (1)	The other defect	<ul style="list-style-type: none"> • The other detected fault.

(1) Flashing

Appendix B

ATV320 Variable Frequency Drive Diagnostics and Trouble Shooting

Model No.

ATV320U15N4, 3-PH, 380-500 VAC

ATV320U07S6C, 3-PH, 525-600 VAC

Diagnostics and Troubleshooting

11

What's in this Chapter?

This chapter contains the following topics:

Topic	Page
Error code	308
Clearing the detected fault	308
Fault detection codes which require a power reset after the detected fault is cleared	308
Fault detection codes that can be cleared with the automatic restart function after the cause has disappeared	311
Fault detection codes that are cleared as soon as their cause disappears	314
Option card changed or removed	314
Control block changed	314
Fault detection codes displayed on the remote display terminal	315

⚠ DANGER

HAZARD OF ELECTRIC SHOCK, EXPLOSION OR ARC FLASH

Read and understand the instructions in "Safety Information" chapter before performing any procedure in this chapter.

Failure to follow these instructions will result in death or serious injury.

Error code

- If the display does not light up, check the power supply to the drive.
- The assignment of the Fast stop or Freewheel functions will help to prevent the drive starting if the corresponding logic inputs are not powered up. The ATV320 then displays **[Freewheel]** (*r 5 t*) in freewheel stop and **[Fast stop]** (*F 5 t*) in fast stop. This is normal since these functions are active at zero so that the drive will be stopped if there is a wire break.
- Check that the run command input is activated in accordance with the selected control mode ((**[2/3 wire control]**) (*t C C*) and **[2 wire type]** (*t C t*) parameters, page [85](#)).
- If an input is assigned to the limit switch function and this input is at zero, the drive can only be started up by sending a command for the opposite direction (see page [224](#)).
- If the reference channel or command channel is assigned to a communication bus, when the power supply is connected, the drive will display **[Freewheel]** (*r 5 t*) and remain in stop mode until the communication bus sends a command.

Code	Name / Description
d G t -	[DIAGNOSTICS] This menu can only be accessed with the graphic display terminal. It displays detected faults and their cause in plain text and can be used to carry out tests, see page 64 .

Clearing the detected fault

In the event of a non resettable detected fault:

- Disconnect all power, including external control power that may be present.
- Lock all power disconnects in the open position.
- Wait 15 minutes to allow the DC bus capacitors to discharge (the drive LEDs are not indicators of the absence of DC bus voltage).
- Measure the voltage of the DC bus between the PA/+ and PC/- terminals to ensure that the voltage is less than 42 Vdc.
- If the DC bus capacitors do not discharge completely, contact your local Schneider Electric representative. Do not repair or operate the drive.
- Find and correct the detected fault.
- Restore power to the drive to confirm the detected fault has been rectified.

In the event of a resettable detected fault, the drive can be reset after the cause is cleared:

- By switching off the drive until the display disappears completely, then switching on again.
- Automatically in the scenarios described for the **[AUTOMATIC RESTART]** (*R t r -*) function, page [252](#).
- By means of a logic input or control bit assigned to the **[FAULT RESET]** (*r 5 t -*) function, page [251](#).
- By pressing the STOP/RESET key on the graphic display keypad if the active channel command is the HMI (see **[Cmd channel 1]** (*C d 1*) page [155](#)).

Fault detection codes which require a power reset after the detected fault is cleared

The cause of the detected fault must be removed before resetting by turning off and then back on.

RSF, *brF*, *SaF*, *SPF* and *EnF* detected faults can also be cleared remotely by means of a logic input or control bit ([*Fault reset*] (*r5F*) parameter, page 251).

Detected Fault	Name	Probable cause	Remedy
<i>RnF</i>	[Load slipping]	<ul style="list-style-type: none"> The difference between the output frequency and the speed feedback is not correct. 	<ul style="list-style-type: none"> Check the motor, gain and stability parameters. Add a braking resistor. Check the size of the motor/drive/load. Check the encoder's mechanical coupling and its wiring. Check the setting of parameters
<i>RSF</i>	[Angle Error]	<ul style="list-style-type: none"> This occurs during the phase-shift angle measurement, if the motor phase is disconnected or if the motor inductance is too high. 	<ul style="list-style-type: none"> Check the motor phases and the maximum current allowed by the drive.
<i>brF</i>	[Brake feedback]	<ul style="list-style-type: none"> The brake feedback contact does not match the brake logic control. The brake does not stop the motor quickly enough (detected by measuring the speed on the "Pulse input" input). 	<ul style="list-style-type: none"> Check the feedback circuit and the brake logic control circuit. Check the mechanical state of the brake. Check the brake linings.
<i>CrF1</i>	[Precharge]	<ul style="list-style-type: none"> Charging relay control detected fault or charging resistor damaged. 	<ul style="list-style-type: none"> Turn the drive off and then turn on again. Check the internal connections. Contact Schneider Electric Product Support.
<i>EEF1</i>	[Control Eeprom]	<ul style="list-style-type: none"> Internal memory detected fault, control block. 	<ul style="list-style-type: none"> Check the environment (electromagnetic compatibility). Turn off, reset, return to factory settings.
<i>EEF2</i>	[Power Eeprom]	<ul style="list-style-type: none"> Internal memory detected fault, power card. 	<ul style="list-style-type: none"> Contact Schneider Electric Product Support.
<i>FCF1</i>	[Out. contact. stuck]	<ul style="list-style-type: none"> The output contactor remains closed although the opening conditions have been met. 	<ul style="list-style-type: none"> Check the contactor and its wiring. Check the feedback circuit.
<i>HdF</i>	[IGBT desaturation]	<ul style="list-style-type: none"> Short-circuit or grounding at the drive output. 	<ul style="list-style-type: none"> Check the cables connecting the drive to the motor, and the motor insulation.
<i>ILF</i>	[Internal com. link]	<ul style="list-style-type: none"> Communication interruption between option card and drive. 	<ul style="list-style-type: none"> Check the environment (electromagnetic compatibility). Check the connections. Replace the option card. Contact Schneider Electric Product Support.
<i>inF1</i>	[Rating error]	<ul style="list-style-type: none"> The power card is different from the card stored. 	<ul style="list-style-type: none"> Check the reference of the power card.
<i>inF2</i>	[Incompatible PB]	<ul style="list-style-type: none"> The power card is incompatible with the control block. 	<ul style="list-style-type: none"> Check the reference of the power card and its compatibility.
<i>inF3</i>	[Internal serial link]	<ul style="list-style-type: none"> Communication interruption between the internal cards. 	<ul style="list-style-type: none"> Check the internal connections. Contact Schneider Electric Product Support.
<i>inF4</i>	[Internal-mfg zone]	<ul style="list-style-type: none"> Internal data inconsistent. 	<ul style="list-style-type: none"> Recalibrate the drive (performed by Schneider Electric Product Support).
<i>inF6</i>	[Internal - fault option]	<ul style="list-style-type: none"> The option installed in the drive is not recognized. 	<ul style="list-style-type: none"> Check the reference and compatibility of the option. Check that the option is well inserted into the ATV320.
<i>inF9</i>	[Internal- I measure]	<ul style="list-style-type: none"> The current measurements are incorrect. 	<ul style="list-style-type: none"> Replace the current sensors or the power card. Contact Schneider Electric Product Support.
<i>inFR</i>	[Internal-mains circuit]	<ul style="list-style-type: none"> The input stage is not operating correctly. 	<ul style="list-style-type: none"> Contact Schneider Electric Product Support.
<i>inFb</i>	[Internal- th. sensor]	<ul style="list-style-type: none"> The drive temperature sensor is not operating correctly. 	<ul style="list-style-type: none"> Replace the drive temperature sensor. Contact Schneider Electric Product Support.
<i>inFE</i>	[Internal- CPU]	<ul style="list-style-type: none"> Internal microprocessor detected fault. 	<ul style="list-style-type: none"> Turn off and reset. Contact Schneider Electric Product Support.
<i>SrFF</i>	[Safety fault]	<ul style="list-style-type: none"> Debounce time exceeded. SS1 threshold exceeded. Wrong configuration. SLS type overspeed detected. 	<ul style="list-style-type: none"> Check the safety functions configuration. Check the ATV320 Integrated safety Functions manual Contact Schneider Electric Product Support.

Detected Fault	Name	Probable cause	Remedy
S o F	[Overspeed]	<ul style="list-style-type: none"> Instability or driving load too high. 	<ul style="list-style-type: none"> Check the motor, gain and stability parameters. Add a braking resistor. Check the size of the motor/drive/load. Check the parameters settings for the [FREQUENCY METER] (F 9 F -) function page 266, if it is configured.
S P F	[Speed fdback loss]	<ul style="list-style-type: none"> Signal on "Pulse input" missing, if the input is used for speed measurement. Encoder feedback signal missing 	<ul style="list-style-type: none"> Check the wiring of the input cable and the detector used. Check the configuration parameters of the encoder. Check the wiring between the encoder and the drive. Check the encoder.

Fault detection codes that can be cleared with the automatic restart function after the cause has disappeared

These detected faults can also be cleared by turning on and off or by means of a logic input or control bit ([Fault reset] (*r S F*) parameter page 251).

Detected Fault	Name	Probable cause	Remedy
<i>b L F</i>	[Brake control]	<ul style="list-style-type: none"> Brake release current not reached. Brake engage frequency threshold [Brake engage freq] (<i>b E n</i>) only regulated when brake logic control is assigned. 	<ul style="list-style-type: none"> Check the drive/motor connection. Check the motor windings. Check the [Brake release I FW] (<i>i b r</i>) and [Brake release I Rev] (<i>i r d</i>) settings page 194. Apply the recommended settings for [Brake engage freq] (<i>b E n</i>).
<i>C n F</i>	[Com. network]	<ul style="list-style-type: none"> Communication interruption on communication card. 	<ul style="list-style-type: none"> Check the environment (electromagnetic compatibility). Check the wiring. Check the time-out. Replace the option card. Contact Schneider Electric Product Support.
<i>C o F</i>	[CANopen com.]	<ul style="list-style-type: none"> Communication interruption on the CANopen® bus. 	<ul style="list-style-type: none"> Check the communication bus. Check the time-out. Refer to the CANopen® User's manual.
<i>E P F 1</i>	[External fit-L/Bit]	<ul style="list-style-type: none"> Event triggered by an external device, depending on user. 	<ul style="list-style-type: none"> Check the device which caused the triggering and reset.
<i>E P F 2</i>	[External fault com.]	<ul style="list-style-type: none"> Event triggered by a communication network. 	<ul style="list-style-type: none"> Check for the cause of the triggering and reset.
<i>F b E S</i>	[FB stop flt.]	<ul style="list-style-type: none"> Function blocks have been stopped while motor was running. 	<ul style="list-style-type: none"> Check [Stop FB Stop motor] (<i>F b S n</i>) configuration.
<i>F C F 2</i>	[Out. contact. open.]	<ul style="list-style-type: none"> The output contactor remains open although the closing conditions have been met. 	<ul style="list-style-type: none"> Check the contactor and its wiring. Check the feedback circuit.
<i>L C F</i>	[input contactor]	<ul style="list-style-type: none"> The drive is not turned on even though [Mains V. time out] (<i>L C t</i>) has elapsed. 	<ul style="list-style-type: none"> Check the contactor and its wiring. Check the time-out. Check the supply mains/contactor/drive connection.
<i>L F F 3</i>	[AI3 4-20mA loss]	<ul style="list-style-type: none"> Loss of the 4-20 mA reference on analog input AI3. 	<ul style="list-style-type: none"> Check the connection on the analog inputs.
<i>o b F</i>	[Overbraking]	<ul style="list-style-type: none"> Braking too sudden or driving load. Supply voltage too high. 	<ul style="list-style-type: none"> Increase the deceleration time. Install a braking resistor if necessary. Activate the [Dec ramp adapt.] (<i>b r R</i>) function page 172, if it is compatible with the application. Check the supply voltage.
<i>o C F</i>	[Overcurrent]	<ul style="list-style-type: none"> Parameters in the [SETTINGS] (<i>S E t -</i>) and [MOTOR CONTROL] (<i>d r C -</i>) menus are not correct. Inertia or load too high. Mechanical locking. 	<ul style="list-style-type: none"> Check the parameters. Check the size of the motor/drive/load. Check the state of the mechanism. Decrease [Current limitation] (<i>C L r</i>). Increase the switching frequency.
<i>o H F</i>	[Drive overheat]	<ul style="list-style-type: none"> Drive temperature too high. 	<ul style="list-style-type: none"> Check the motor load, the drive ventilation and the ambient temperature. Wait for the drive to cool down before restarting.
<i>o L C</i>	[Proc. overload flt]	<ul style="list-style-type: none"> Process overload. 	<ul style="list-style-type: none"> Check and remove the cause of the overload. Check the parameters of the [PROCESS OVERLOAD] (<i>o L d -</i>) function, page 272.
<i>o L F</i>	[Motor overload]	<ul style="list-style-type: none"> Triggered by excessive motor current. 	<ul style="list-style-type: none"> Check the setting of the motor thermal protection, check the motor load. Wait for the motor to cool down before restarting.
<i>o P F 1</i>	[1 output phase loss]	<ul style="list-style-type: none"> Loss of one phase at drive output. 	<ul style="list-style-type: none"> Check the connections from the drive to the motor.

Detected Fault	Name	Probable cause	Remedy
o P F 2	[3 motor phase loss]	<ul style="list-style-type: none"> Motor not connected or motor power too low. Output contactor open. Instantaneous instability in the motor current. 	<ul style="list-style-type: none"> Check the connections from the drive to the motor. If an output contactor is being used, set [Output Phase Loss] (o P L) to [Output cut] (o P C), page 256. Test on a low power motor or without a motor: In factory settings mode, motor phase loss detection is active [Output Phase Loss] (o P L) = [Yes] (Y E S). To check the drive in a test or maintenance environment, without having to use a motor with the same rating as the drive (in particular for high power drives), deactivate motor phase loss detection [Output Phase Loss] (o P L) = [No] (n o), see instructions given page 256. Check and optimize the following parameters: [IR compensation] (u F r) page 90, [Rated motor volt.] (u n S) and [Rated mot. current] (n C r) page 86 and perform [Auto tuning] (t u n) page 87.
o S F	[Mains overvoltage]	<ul style="list-style-type: none"> Supply voltage too high. Disturbed mains supply. 	<ul style="list-style-type: none"> Check the supply voltage.
o t F L	[LI6=PTC overheat]	<ul style="list-style-type: none"> Overheating of PTC probes detected on input LI6. 	<ul style="list-style-type: none"> Check the motor load and motor size. Check the motor ventilation. Wait for the motor to cool before restarting. Check the type and state of the PTC probes.
P t F L	[LI6=PTC probe]	<ul style="list-style-type: none"> PTC probe on input LI6 open or short-circuited. 	<ul style="list-style-type: none"> Check the PTC probe and the wiring between it and the motor/drive.
S C F 1	[Motor short circuit]	<ul style="list-style-type: none"> Short-circuit or grounding at the drive output. 	<ul style="list-style-type: none"> Check the cables connecting the drive to the motor, and the motor insulation. Reduce the switching frequency. Connect chokes in series with the motor. Check the adjustment of speed loop and brake. Increase the [Time to restart] (t t r), page 101. Increase the switching frequency.
S C F 3	[Ground short circuit]	<ul style="list-style-type: none"> Significant earth leakage current at the drive output if several motors are connected in parallel. 	<ul style="list-style-type: none"> Check the cables connecting the drive to the motor, and the motor insulation. Reduce the switching frequency. Connect chokes in series with the motor. Check the adjustment of speed loop and brake. Increase the [Time to restart] (t t r), page 101. Reduce the switching frequency.
S C F 4	[IGBT short circuit]	<ul style="list-style-type: none"> Power component detected fault. 	<ul style="list-style-type: none"> Contact Schneider Electric Product Support.
S C F 5	[Motor short circuit]	<ul style="list-style-type: none"> Short-circuit at drive output. 	<ul style="list-style-type: none"> Check the cables connecting the drive to the motor, and the motor's insulation. Contact Schneider Electric Product Support.
S L F 1	[Modbus com.]	<ul style="list-style-type: none"> Communication interruption on the Modbus bus. 	<ul style="list-style-type: none"> Check the communication bus. Check the time-out. Refer to the Modbus User's manual.
S L F 2	[PC com.]	<ul style="list-style-type: none"> Communication interruption with PC Software. 	<ul style="list-style-type: none"> Check the PC Software connecting cable. Check the time-out.
S L F 3	[HMI com.]	<ul style="list-style-type: none"> Communication interruption with the graphic display terminal or remote display terminal. 	<ul style="list-style-type: none"> Check the terminal connection Check the time-out.
S S F	[Torque/current lim]	<ul style="list-style-type: none"> Switch to torque or current limitation. 	<ul style="list-style-type: none"> Check if there are any mechanical problems. Check the parameters of [TORQUE LIMITATION] (t o L -) page 216 and the parameters of the [TORQUE OR I LIM. DETECT.] (t i d -), page 264.
t J F	[IGBT overheat]	<ul style="list-style-type: none"> Drive overheated. 	<ul style="list-style-type: none"> Check the size of the load/motor/drive. Reduce the switching frequency. Wait for the motor to cool before restarting.

Diagnostics and Troubleshooting

Detected Fault	Name	Probable cause	Remedy
<i>ENF</i>	[Auto-tuning]	<ul style="list-style-type: none"> • Special motor or motor whose power is not suitable for the drive. • Motor not connected to the drive. • Motor not stopped 	<ul style="list-style-type: none"> • Check that the motor/drive are compatible. • Check that the motor is present during auto-tuning. • If an output contactor is being used, close it during auto-tuning. • Check that the motor is stopped during tune operation.
<i>ULF</i>	[Proc. underload Flt]	<ul style="list-style-type: none"> • Process underload. 	<ul style="list-style-type: none"> • Check and remove the cause of the underload. • Check the parameters of the [PROCESS UNDERLOAD] (<i>u L d -</i>) function, page 270.

Fault detection codes that are cleared as soon as their cause disappears

Detected Fault	Name	Probable cause	Remedy
CFF	[Incorrect config.]	<ul style="list-style-type: none"> Option card changed or removed. Control block replaced by a control block configured on a drive with a different rating. The current configuration is inconsistent. 	<ul style="list-style-type: none"> Check that there are no card errors. In the event of the option card being changed/removed deliberately, see the remarks below. Check that there are no card errors. In the event of the control block being changed deliberately, see the remarks below. Return to factory settings or retrieve the backup configuration, if it is valid (see page 81).
CF1 CF12	[Invalid config.]	<ul style="list-style-type: none"> Invalid configuration. The configuration loaded in the drive via the bus or communication network is inconsistent. 	<ul style="list-style-type: none"> Check the configuration loaded previously. Load a compatible configuration.
CSF	[Ch. Sw. fault]	<ul style="list-style-type: none"> Switch to not valid channels. 	<ul style="list-style-type: none"> Check the function parameters.
dLF	[Dynamic load fault]	<ul style="list-style-type: none"> Abnormal load variation. 	<ul style="list-style-type: none"> Check that the load is not blocked by an obstacle. Removal of a run command causes a reset.
FbE	[FB fault]	<ul style="list-style-type: none"> Function blocks error. 	<ul style="list-style-type: none"> See [FB Fault] (FbE) for more details.
HCF	[Cards pairing]	<ul style="list-style-type: none"> The [CARDS PAIRING] (PP1-) function page 269 has been configured and a drive card has been changed. 	<ul style="list-style-type: none"> In the event of a card error, reinsert the original card. Confirm the configuration by entering the [Pairing password] (PP1) if the card was changed deliberately.
PHF	[Input phase loss]	<ul style="list-style-type: none"> Drive incorrectly supplied or a fuse blown. One phase missing. 3-phase ATV320 used on a single-phase supply mains. Unbalanced load. <p>This protection only operates with the drive on load.</p>	<ul style="list-style-type: none"> Check the power connection and the fuses. Use a 3-phase supply mains. Disable the detected fault by [Input phase loss] (PL) = [No] (no) page 86.
uSF	[Undervoltage]	<ul style="list-style-type: none"> Supply mains too low. Transient voltage dip. 	<ul style="list-style-type: none"> Check the voltage and the parameters of [UNDERVOLTAGE MGT] (uSb-), page 259.

Option card changed or removed

When an option card is removed or replaced by another, the drive locks in [Incorrect config.] (CFF) fault mode on power-up. If the card has been deliberately changed or removed, the detected fault can be cleared by pressing the ENT key twice, which causes the factory settings to be restored (see page 81) for the parameter groups affected by the card. These are as follows:

Card replaced by a card of the same type

- Communication cards: only the parameters that are specific to communication cards

Control block changed

When a control block is replaced by a control block configured on a drive with a different rating, the drive locks in [Incorrect config.] (CFF) fault mode on power-up. If the control block has been deliberately changed, the detected fault can be cleared by pressing the ENT key twice, which causes all the factory settings to be restored.

Fault detection codes displayed on the remote display terminal

Code	Name	Description
i n i t (1)	[Initialization in progress]	The microcontroller is initializing. Search underway for communication configuration.
C o m . E (1)	[Communication error]	Time out detected fault (50 ms). This message is displayed after 20 attempts at communication.
A - 1 7 (1)	[Alarm button]	A key has been held down for more than 10 seconds. The keypad is disconnected. The keypad wakes up when a key is pressed.
C L r (1)	[Confirmation of detected fault reset]	This is displayed when the STOP key is pressed once if the active command channel is the remote display terminal.
d E u . E (1)	[Drive disparity]	The drive brand does not match that of the remote display terminal.
r o m . E (1)	[ROM anomaly]	The remote display terminal detects a ROM anomaly on the basis of checksum calculation.
r a m . E (1)	[RAM anomaly]	The remote display terminal detects a RAM anomaly.
C P u . E (1)	[Other detected faults]	Other detected faults.

(1) Flashing

Appendix C

IS7079

VekteK Electronic Pressure Switch

Specifications & Programming

OPERATING INSTRUCTIONS

Vektek Electronic Pressure Switch: 70740075



1	General information.....	1
2	Structure and function.....	2
3	Safety.....	4
4	Transport, packaging and storage.....	6
5	Commissioning, operation.....	9
6	Faults.....	19
7	Maintenance and cleaning.....	23
8	Disassembly, return and disposal.....	24
9	Technical data.....	26

VEKTEK LLC
1334 E 6th Ave
Emporia, Ks 66801
USA
Phone: 913-366-1045 (sales)
Fax: 816-364-0471 (sales)
620-342-7637 (technical service)
Email: sales@vektek.com
Website: www.vektek.com

IB		7079	
REV.	A	EFF. DATE	1/10/24
ECN NO.		S160	
BY / DATE:		KR	12/01/23
APPR. / DATE:		BCD	12/01/23
REV APPR. / DATE:			

1 General information

- The device described in the operating instructions was designed and manufactured in accordance with current state-of-the-art technology. All components are subject to strict quality and environmental criteria during production. Our management systems are certified in line with ISO 9001 and ISO 14001.
- These operating instructions provide important information on how to use the device. Adherence to all the specified safety notes and guidelines is a prerequisite for working safely.
- You must comply with any local work safety regulations and general safety specifications applicable to the use of the device.
- They constitute an integral part of the product and should be stored in the direct vicinity of the device so they remain accessible to the technical personnel at all times. Give the operating instructions to any future users or owners of the device.
- The technical personnel must read through these operating instructions carefully and understand them before starting any work.
- The general business conditions in the sales documents apply.
- We reserve the right to make technical modifications.
- More information:
Internet address: www.sick.com
Associated data sheet: 8024860

2 Structure and function

2.1 Scope of delivery

- Pressure switch
- Operating instructions
- Test report
- Compare the scope of delivery with the delivery note.

2.2 Overview



- ① INFO pushbutton
- ② Digital display
- ③ Status display, switching outputs
- ④ MENU pushbutton
- ⑤ Confirmation pushbutton
- ⑥ Electrical connection
- ⑦ Process connection, spanner flat
- ⑧ Process connection, thread

2.3 Display and control unit

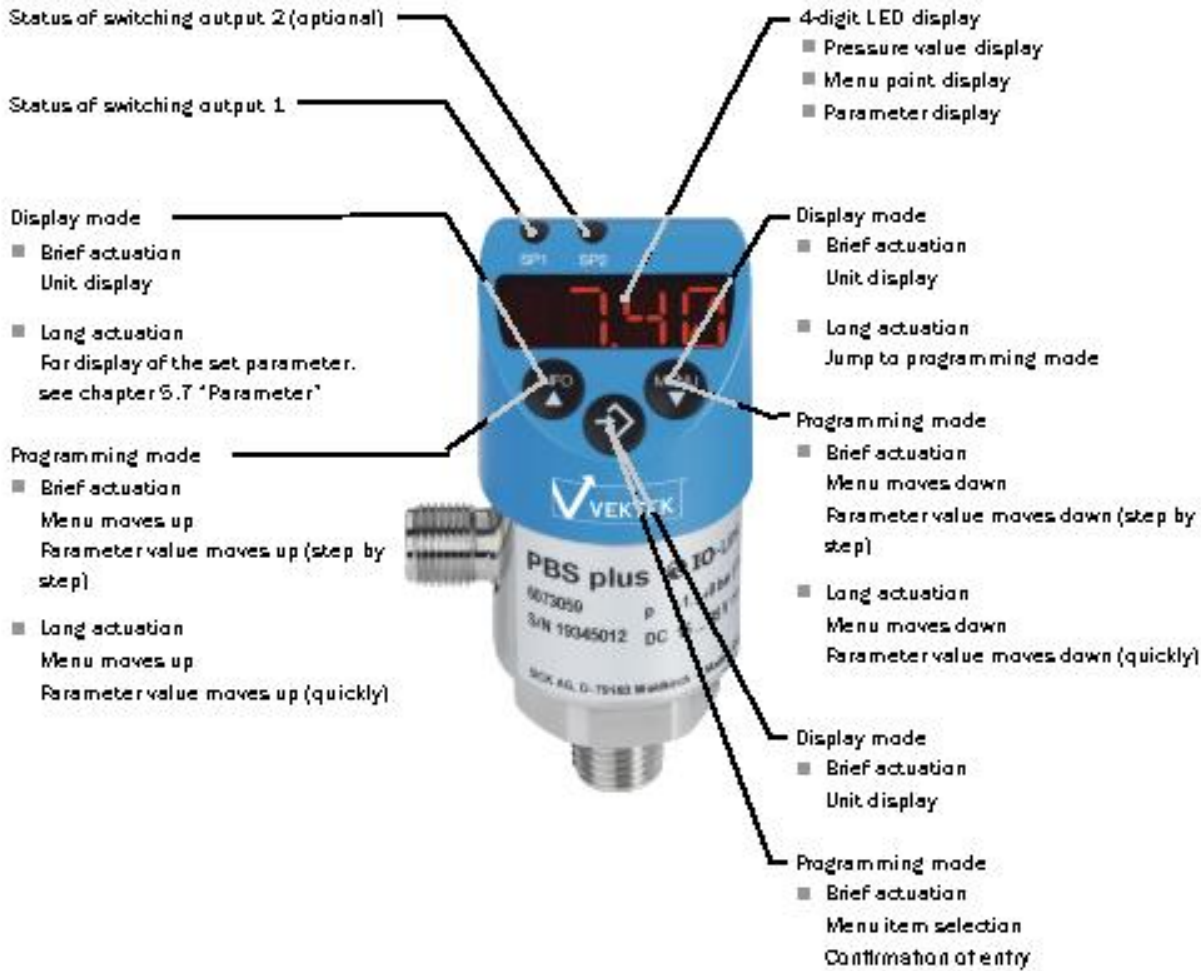

3. Safety

3.1 Explanation of icons

**WARNING!**

... indicates a potentially dangerous situation, which may lead to a fatality or serious injuries if not prevented.

**CAUTION!**

... indicates a potentially dangerous situation, which may lead to minor/slight injuries or property or environmental damage if not prevented.

**WARNING!**

... indicates a potentially dangerous situation which could lead to burns caused by hot surfaces or liquids if not prevented.

**Information**

... highlights useful tips and recommendations as well as information for efficient and trouble-free operation.

Conformities and certificates

You can obtain declarations of conformity, certificates, and the current operating instructions for the product at www.sick.com. To do so, enter the product part number in the search field (part number: see the entry in the "P/N" or "Ident. no." field on the type label).

3.2 Intended use

The device is designed and manufactured exclusively for the intended purpose of use described here and may only be used in accordance with this purpose.

Any claims made due to unintended use are excluded.

Purpose

The PBS plus pressure switch is used to switch power circuits depending on the measured pressure. The pressure value can also be output to the respective evaluation units as a standardized signal. The switching conditions can be programmed directly on the pressure switch (switching and resetting points...). Switching conditions and pressure values can be read off using the various display elements.

This is a device of class B for emitted interference and is intended for operation in industrial environments. In other environments, e.g. residential or commercial areas, it could interfere with other devices under certain circumstances. In this case, the operating entity may be required to take appropriate measures.

Only use the pressure switch in applications which are within its technical performance limits (e.g. max. ambient temperature, material compatibility, ...).

– For performance limits, see Chapter 9 "Technical data".

Technical restrictions

- The overload pressure must not be exceeded at any time, even when faults in the end application occur. Strains exceeding the overload protection can cause measurement errors.
- Pressure surges above the nominal pressure and for less than 1 ms can cause measurement errors.
- The use of a choke is recommended for applications for which pressure peaks occur. The choke restricts the pressure channel to 0.3 mm, thereby increasing the resistance to pressure peaks.

Alternatively, a process connection with reduced channel bore hole (0.3 mm or 0.6 mm) can be used.

- A flush-mounted device version must be used for measuring materials which could clog a channel bore hole (e.g. particle board).
- At high ambient temperatures and high UV radiation, the pressure switch must be installed with additional shading to prevent damage to the digital display and pushbuttons.
- The measuring material temperature in the device must not exceed 85 °C. A cooling line can be helpful for hotter measuring materials.

3.3 Personnel qualification

Technical personnel

Due to their specialist training, knowledge of measuring and control technology, and experience, as well as their knowledge of country-specific regulations and the relevant standards and provisions, the technical personnel authorized by the operating entity are able to perform the work described and detect any potential dangers independently.

Special application conditions require other knowledge, e.g. of aggressive media.

3.4 Use of accessories and spare parts

We recommend using only original spare parts and original accessories from SICK. The use of accessories and spare parts from third parties could lead to damage to the device or accidents due to shortcomings in quality or other reasons.

SICK does not assume any liability for damages or accidents which occur due to malfunctions or unsuitability of accessories and spare parts which are not produced by SICK (e.g. non-compliance with IP enclosure rating of plug connectors). No warranty claims which are caused by malfunction or unsuitability of accessories or spare parts from third parties can be asserted.

3.5 Safety labels

Icons



Read the operating instructions before mounting and commissioning of the device without fail!

4. Transport, packaging and storage



The flush-mounted version is delivered with a special protective cap to protect the membrane.

- Manually remove this protective cap just before mounting to prevent damage to the membrane or the process connection thread.
- Keep the protective cap for storage or transport.
- Mount the protective cap when removing and transporting the device.

4.1 Transport

Examine the pressure switch for any damage that may have occurred in transit. Also check the membrane for optical damage when using a flush-mounted version.

Report any obvious damage immediately.

4.2 Packaging and storage

Do not remove packaging until immediately before assembly.

Retain the packaging as it offers ideal protection during transport (e.g., when changing the installation site or sending for repair).

Permissible conditions at the storage location:

Storage temperature: -20 ... +70 °C

Humidity: 45 ... 75% relative humidity (no condensation)

Mount the protective cap to protect the membrane before putting into storage.

5. Commissioning, operation

5.1 Checking device

Do a visual inspection of the pressure switch before commissioning.

- Escaping liquids indicate damage.
- Only use the pressure switch when its safety technology is working perfectly.
- Do an optical inspection for membrane damage, this is a safety-relevant part.

5.2 Requirements on the mounting location

The mounting location must fulfill the following conditions:

- Protected from weather influences.
- At high ambient temperatures and high UV radiation, the pressure switch must be installed with additional shading to prevent damage to the digital display and pushbuttons.
- Sealing surfaces are clean and undamaged.
- Sufficient space for safe electrical installation.
- For information on threaded bore holes and weld-in connections, see the technical information at www.SICK.de.
- Permissible ambient and measuring material temperatures remain within the performance limits. Take into account possible restrictions on the ambient temperature range due to the mating plug used.
- – For performance limits, see Chapter 9 "Technical data".

5.3 Mechanical mounting

The maximum torque depends on the mounting location (e.g. material and shape). If you have any questions, please consult our application advisor.

– For contact information, see chapter 1 "General" or the rear side of the operating instructions.

1. Seal sealing surface (– see "Sealing variants").
2. Tighten the pressure switch in the mounting location by hand.
3. Tighten via spanner flat using torque wrench.

Sealing variants

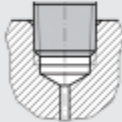
<p>Cylindrical thread Seal sealing surface with SAE 4 O-Ring Boss Seal</p>	
<p>Conical thread Wrap sealing material around thread (e.g. PTFE band).</p>	 <p>NPT, R and PT</p>

5.4 Electrical mounting

5.4.1 Requirements on voltage supply

– For auxiliary energy, see type label

The pressure switch must be supplied by an energy-limited circuit as per 9.4 of the UL/EN/IEC 61010-1 or LPS as per UL/EN/IEC 60950-1 / CSA C22.2 No.60950-1 or class 2 as per UL1310 / UL1585 (NEC or CEC).

The voltage supply must be suited for operation above 2,000 m if the pressure switch is used from this height.

5.4.2 Requirements on the electrical connection

- The enclosure rating of the mating plug corresponds to the enclosure rating of the pressure switch.
- Cable diameter matches the cable gland of the mating plug.
- The cable gland and seals of the mating plug sit correctly.
- No moisture can penetrate into the cable end.

5.4.3 Requirement on shielding and earthing

The pressure switch must be shielded and earthed according to the earthing method of the application.

5.4.4 Connecting the device

1. Assemble the mating plug or the cable output – For connection assignment, see type label
2. Establish plug connection.

Electrical connections					
		Round connector M12x1.5-pin			
					
		2 switching outputs + 1 analog output			
		L+ = 1	M = 3	Q1 = 4 C/Q1 = 4	Q2 = 5 Q, = 2
Enclosure rating as per IEC 60 529		IP 67			
		The enclosure ratings specified apply only with male cable connectors of the corresponding enclosure rating when plugged in.			

5.5 Zero point adjustment

Check the zero point shown on the digital display during commissioning. If, for installation reasons, a zero point offset is displayed, this can be reset in programming mode using the OSET parameter. Run zero point adjustment for gauge pressure and vacuum measurement ranges in a de-pressurized state.

 Run zero point adjustment of absolute pressure measurement ranges at 0 bar absolute (vacuum). Since corresponding references are required for this purpose, we recommend only having this done by the manufacturer.

5.6 Operating modes

Mode	Programming mode
System start	Digital display is completely controlled for 1 sec. When starting up the pressure switch in the hysteresis range, the output switch is set to "not active" by default.
Programming mode (Setting of parameters)	Activate programming mode Actuate the "MENU" pushbutton for about 5 sec. If password *0000 is set, a password request occurs. If confirmation is successful, access to programming mode is granted; otherwise the system jumps back to display mode. Timeout If no pushbutton is pressed for 60 s when a parameter is being set, the device returns to the display mode with the value unchanged.
Display mode (Normal working operation, pressure value display)	Return to display mode Simultaneous actuation of "INFO" and "MENU"

5.7 Overview of parameters

Menu item	Description	Parameter	Factory setting
SP1 / SP2	Hysteresis function: Switching point (switching device 1 / 2)	0.25 ... 100% of the measuring range	5000 / 5000
FH1 / FH2	Window function: Window High (switching output 1 / 2)	0.25 ... 100% of the measuring range	5800 / 5800
RP1 / RP2	Hysteresis function, reset switching point, switching output (1, possibly 2)	0 ... (switching point - 0.25% of the measuring range)	4500 / 4500
FL1 / FL2	Window function: Window Low switching output (1, possibly 2)	0 ... (Window High - 0.25% of the measuring range)	0 / 0
EF	Extended programming functions		
RES	Resetting of the set parameters back to the factory settings	Yes / No	
DS1 / DS2	Switching delay time which must not be interrupted until an electrical signal switch takes place (SP1, possibly SP2)	0.00 ... 65.00 s	0.00 s
DR1 / DR2	Reset switching delay time which must not be interrupted until an electrical signal switch takes place (RP1, possibly RP2)	0.00 ... 65.00 s	0.00 s
OU1 / OU2	Switching function (switching output 1 / 2)	HNO = Hysteresis function, normally open HNC = Hysteresis function, normally closed FNO = Window function, normally open FNC = Window function, normally closed	HNC / FNO
OU3	Output signal switchover	I = 4 ... 20 mA U = DC 0 ... 10 V	I
POL1 / POL2	Switching logic (switching output 1 / 2)	PNP, NPN	PNP
ALOW	Measuring range scaling/Turn down (analog value, start value)	Corresponding analog output	0
AHGH	Measuring range scaling/Turn down (analog value, end value)	Corresponding analog output	5800

Menu item	Description	Parameter	Factory setting
AVGD	Attenuation (digital display)	0.00 ... 65.00 s	0.20 s
AVG1 / AVG2	Attenuation (switching output 1 / 2)	0.00 ... 65.00 s	0.00 s
AVG3	Attenuation (analog signal)	0.00 ... 65.00 s	0.1
UNIT	Unit switchover	BAR, mBAR, MPA, KPA, PSI, KGcm (kg/cm ²), %	PSI
OS ET	Zero point adjustment / 'Auto-zero' version (max. 3% of the range)	Yes / No	No
DISM	Display value in display mode	ACT = Current system pressure LOW, HIGH = Min/Max system pressure OFF = Display off SP1 / FH1 = Set threshold value RP1 / FL1 = Set threshold value SP2 / FH2 = Set threshold value RP2 / FL2 = Set threshold value	ACT
DISU	Update rate (digital display)	1, 2, 5, 10 updates/second	5
DISR	Turn display 180° (digital display)	Yes / No	No
DRES	Resolution (digital display)	OPT = Optimized (stable measurement value display with the rounding factor of the last digit optimized to the measuring range) FULL = Maximum (finest resolution, an attenuation of the digital display might have to be set for a stable measurement value display)	OPT
RHL	Delete memory (min/max system pressure)	Yes / No	Yes, reset after testing
PAS	Password entry	0000 = No password, password entry digit by digit	0000
TAG	Measurement device name (TAG)	32 selectable characters (A-Z, 0 ... 9, -, ., EMPTY) (2 spaces in a row end entry and causes this and the character behind it to be deleted)	without

5.8 Menu tree

Certain menu items (light gray) are only displayed if the pressure switch features the respective option.

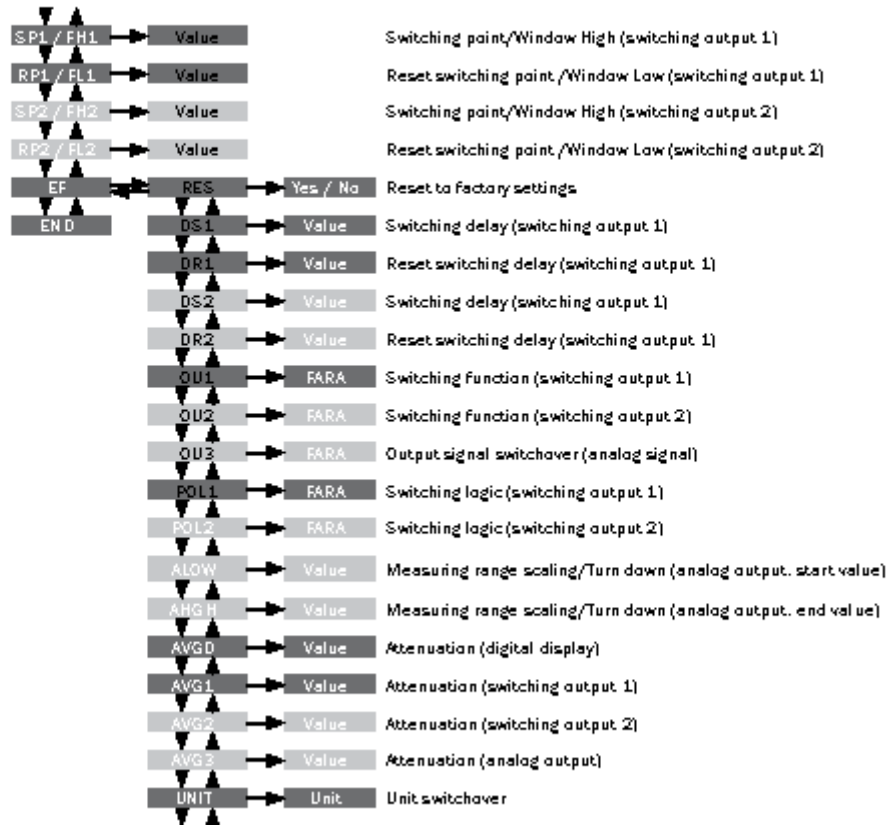

OS ET	Yes / No	Zero point adjustment
DISM	PARA	Display value in display mode
DISU	Value	Update rate (digital display)
DISR	Yes / No	Turn display 180° (digital display)
DRES	PARA	Resolution (digital display)
RHL	Yes / No	Delete min/max memory
PAS	Value	Password entry
TAG	Value	Measurement device name (TAG)
END		

5.9 Switching functions

Hysteresis functions

If the system pressure is fluctuating around the set value, the hysteresis keeps the output state of the outputs stable. In the event of rising system pressure, the output switches upon reaching the switching point (SP).

- N/O contact (HNO): Active
- N/C contact (HNC): Deactivated

If the system pressure drops again, the output does not switch back until the reset point (RP) has been reached.

- N/O contact (HNO): Deactivated
- N/C contact (HNC): Active

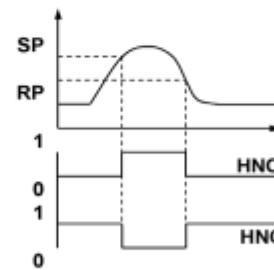

Fig.: Hysteresis function

Window function

The window function enables monitoring of a defined range. If the system pressure is between window High (FH) and window Low (FL), the output switches.

- N/D contact (FNO): Active
- N/C contact (FNC): Deactivated

If the system pressure is outside window High (FH) and window Low (FL), the output does not switch.

- N/D contact (FNO): Deactivated
- N/C contact (FNC): Active

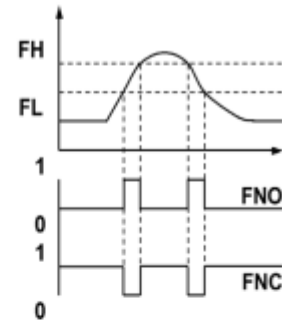

Fig.: Window Function

Delay times (0 ... 65 s)

Undesirable pressure peaks of short duration and high frequency can be filtered out in this way.

The pressure must be present for a set time so that the output switches. The output does not change its status immediately when achieving the switching event (SP); instead, it does so after the set delay time (DS).

If the switching result is no longer available after the delay time has expired, the switching output does not change. The output does not reset until the system pressure has fallen to the reset switching point (RP) and at least the set delay time (DR) remains at or below the reset switching point (RP).

If the switching result is no longer available after the delay time has expired, the switching output does not change.

5.10 Attenuation function

Time constant "x" specifies the amount of time which the digital display, the switching output or the analog signal needs to approach the end value with a deviation of $\pm 1\%$ after a measurement value change. After a duration of 2 times "x", the output value has achieved 100% with a deviation of $\pm 0.01\%$ of the prevailing pressure.

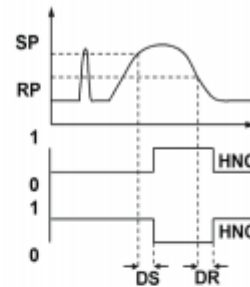

Fig.: Delay times

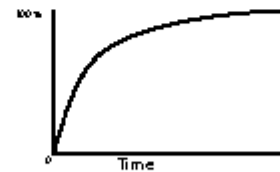

Fig.: Attenuation Function

5.11 Measuring range scaling (turn down)

In variants with analog signal, the measuring range beginning and measuring range end can be adjusted within the permissible measuring range (do not exceed turn down of 5:1).

5.12 Description of IO-Link functionality

IO-Link is a point-to-point connection for communication of the PBS plus to an IO-Link master.

IO-Link specification: Version 1.1

A detailed description of the IO-Link function as well as the device description file (IODD) can be found online on the detailed product page of the pressure switch at www.sick.com.

6. Faults



CAUTION!

Bodily injury, property and environmental damage

If faults cannot be eliminated by the measures listed here, put the pressure switch out of operation immediately.

- Ensure that there is no pressure or signal present and protect against accidental commissioning. If measuring range scaling is set, pressure can be present despite an analog value of 4 mA or 0 V.
- Contact the manufacturer.
- If the product has to be returned, follow the instruction in chapter 8.2 "Returns".

**WARNING!****Bodily injury, property and environmental damage caused by hazardous measuring materials**

When coming into contact with hazardous measuring materials (e.g. oxygen, acetylene, combustible or poisonous materials), measuring materials which are hazardous to health (e.g. corrosive, poisonous, carcinogenic, radioactive) as well as cooling systems and compressors, there is a risk of bodily injury as well as property and environmental damage.

- In the event of faults, aggressive measuring materials at extreme temperatures and under extreme pressure may be present on the device.
- The relevant regulations must be observed in addition to the general rules for these measuring materials.
- Wear the necessary protective equipment.



For contact information, see chapter 1 "General" or the rear side of the operating instructions.

In the event of faults, check whether the mechanical or electrical installation of the pressure switch is correct.

Processing costs will be charged if the complaint is not justified.

Fault	Possible cause	Measure
No output signal	Line break	Check passage
No output signal	No/Incorrect auxiliary energy	Correct auxiliary energy
No/Incorrect output signal	Wiring error or switchover of switching logic/analog signal	Observe pin assignment Check output configuration Observe pin assignment
Constant output signal during change in pressure	Mechanical overload due to excessive pressure	Exchange device: consult with the manufacturer in the event of repeated failure
Deviating zero point signal	Overload pressure limit exceeded	Permissible overload pressure limit upheld
Signal range too small	Mechanical overload due to excessive pressure	Exchange device: consult with the manufacturer in the event of repeated failure
Signal range too small	Auxiliary voltage too high/low	Correct auxiliary energy
Signal range falls	Moisture has entered the device	Mount cable correctly
Signal range falls/too small	Membrane damage, e.g. caused by abrasive/aggressive media, corrosion to membrane/process connection	Contact manufacturer and exchange device

Warnings and errors

Device-internal warnings and errors are output via the digital display. The device continues to measure if there are pending warnings. The output signal and the switching outputs continue to be output.

The following table shows the codes and their meaning.

Warning	Description
ATT1	When the switching point was changed, the reset switching point was automatically lowered by the smallest hysteresis of 0.25% by the device.
ATT2	Zero point offset, prevailing pressure outside the limits
ATT3	Password entry for menu access faulty
ATT4	Unit cannot be shown on the display, previous unit is used

Warning	Description
MTS	Maximum turn down exceeded
ILOC	Menu locked by IO-Link
OL	Overload pressure, measuring range exceeded > about 3.125% (digital display flashes)
PAS	Request for password entry
UL	Underload pressure, measuring range undercut < about 3.125% (digital display flashes)

Error	Description
ERR	Internal error (device restart or reset to factory setting could help) The analog output controls the alarm signal ≤ 3.5 mA (4 ... 20 mA output signal) or ≥ 11 V (0 ... 10 V output signal) in accordance with NAMUR43 The switching outputs maintain the current switching state (output open or closed)
ERR1	Device temperature exceeded/undercut or auxiliary energy undercut The analog output is output. There are limits regarding accuracy (influence of temperature) and maximum analog value (auxiliary energy undercut) The switching outputs maintain the current switching state (output open or closed)
ERR2	Sensor defect detected, check whether high overload pressure exists (can be detected as sensor defect), a device restart or device exchange may be necessary The analog output controls the alarm signal ≤ 3.5 mA (4 ... 20 mA output signal) or ≥ 11 V (0 ... 10 V output signal) in accordance with NAMUR43 The switching outputs maintain the current switching state (output open or closed)
SC	Short-circuit on switching output 1 or 2 detected The affected switching output is deactivated as long as the short-circuit exists

Confirm warnings and errors with confirmation pushbutton.

7. Maintenance and cleaning

7.1 Maintenance

This pressure switch is maintenance-free.

Repairs may only be carried out by the manufacturer.

7.2 Cleaning



CAUTION!

Unsuitable cleaning agents

Cleaning with unsuitable cleaning agents can damage the device and type label.

- Do not use aggressive cleaning agents.
- Do not use hard or pointy objects.
- Do not use abrasive cloths or sponges.

Suitable cleaning agents

- Water
- Commercial dishwasher liquid

Cleaning the device

Wipe the device surface with a soft, damp cloth.

8. Disassembly, return and disposal

8.1 Disassembly

**WARNING!**

Bodily injury, property and environmental damage caused by hazardous measuring materials

When coming into contact with hazardous measuring materials (e.g. oxygen, acetylene, combustible or poisonous materials), measuring materials which are hazardous to health (e.g. corrosive, poisonous, carcinogenic, radioactive) as well as cooling systems and compressors, there is a risk of bodily injury as well as property and environmental damage.

- In the event of faults, aggressive measuring materials at extreme temperatures and under extreme pressure may be present on the device.
- Wear necessary protective equipment.

**WARNING!**

Risk of burns

During removal, there is risk that hot, dangerous measuring materials will escape.

The pressure switch can heat up due to hot measuring materials.

- Let the device cool sufficiently before removal.
- Wear necessary protective equipment.

Disassembling the device

1. De-pressurize and de-energize the pressure switch.
2. Disconnect electrical connection.
3. Remove the pressure switch via the spanner flat using the socket wrench.

8.2 Returns

When returning the device, it is crucial to note the following:

All devices delivered to SICK must be free from hazardous substances (acids, lyes, solutions, etc.) and must therefore be cleaned before they are returned. A corresponding declaration of clearance must be enclosed with the sensor. You will find this on our Internet page.



WARNING!

Bodily injury, property and environmental damage caused by measuring material residues

Measuring material residues in the removed device could be hazardous to persons, equipment and the environment.

- If there are hazardous materials, enclose the safety data sheet for the respective measuring material.
- Clean device, see chapter 7.2 "Cleaning".

The device must be returned in its original packaging or packaging that is suitable for transport purposes.



You can find information on returns in the "Service" section on our local Internet page.

8.3 Disposal

Incorrect disposal could endanger the environment.

Dispose of device components and packaging materials in compliance with country-specific waste treatment and disposal regulations and in an environmentally-friendly manner.

9. Technical data

Technical data		
Measuring range		
Measuring range	See type label	
Overload protection	Overload protection refers to the sensor element used. Depending on the process connection and seal used, the overload protection could be limited. ≤ 600 bar (< 8.70.2 psi): 2-fold 1.000 bar (14.504 psi): 1.5-fold	
Increased overload protection (option)	Deviating temperature errors, signal noise and long-term stability occur with increased overload protection.	
Vacuum-tight	Yes	
Digital display		
Type	14-Segment LED, red, 4-digit, character height 9 mm (0.35 in) Display can be rotated electrically by 180°	
Output signal		
Output signal	See type label	
Load resistance	4 ... 20 mA	$\leq 500 \Omega$
	DC0 ... 1.0 V	> Max. output voltage / 1 mA
IO-Link (option)	Version 1.1	
Zero point adjustment	Max. 3% of the range	
Analog output/Switching output attenuation	Can be configured from 0 ms ... 65 s	
Power-up delay	1 s	
Switching thresholds	Switching point 1 and switching point 2 can each be adjusted individually	
Switching functions	Normally open, normally closed, window, hysteresis (freely adjustable)	
Switching voltage	Auxiliary energy - 1 V	
Switching current	Max. 250 mA	

Technical data	
Setting timer/ Response time	Analog signal: ≤ 5 ms Switching output: ≤ 5 ms
Service life	100 million switching changes
Voltage supply	
Auxiliary energy	DC 15 ... 35 V The pressure switch must be supplied by an energy-limited circuit as per 9.3 of the UL/EN/IEC 61010-1 or LPS as per UL/EN/IEC 60950-1 or class 2 as per UL1310 / UL1585 (NEC or CEC). The voltage supply must be suited for operation above 2,000 m if the pressure switch is used from this height.
Power consumption	Max. 45 mA for versions without 4 ... 20 mA output signal Max. 70 mA for versions with 4 ... 20 mA output signal
Total power consumption	Max. 800 mA including switching current
Accuracy information	
Accuracy, analog signal	$\leq \pm 0.5\%$ of the range Inclusive of non-linearity, hysteresis, zero point and full-scale error (corresponds to error of measurement as per IEC 61298-2).
Non-repeatability, analog signal	$\leq 0.1\%$ of the range (IEC 61298-2)
long-term drift, analog signal	$\leq \pm 0.1\%$ of the range (IEC 61298-2) $\leq \pm 0.2\%$ of the range (IEC 61298-2) for measuring ranges ≤ 0.6 bar (9 psi), flush-mounted process connection, increased overload protection
Turn down, analog signal	In the range of max. 5:1, the analog output signal can be freely scaled. If a turn down is set, proportionally increased measurement deviations and temperature errors apply.
Accuracy, signal output	$\leq \pm 0.5\%$ of the range
Temperature error in nominal temperature range	Maximal: $\leq \pm 1.5\%$ of the range Maximal: $\leq \pm 2.5\%$ of the range for increased overload protection and flush-mounted versions
Temperature coefficients in nominal temperature range	Average TC zero point $\leq \pm 0.16\%$ of the range / 10 K Average TC range $\leq \pm 0.16\%$ of the range / 10 K

Technical data	
Reference conditions (as per IEC 61298-1)	
Ambient temperature	15 ... 25 °C (59 ... 77 °F)
Air pressure	860 ... 1.060 mbar (12.5 ... 15.4 psi)
Air humidity	45 ... 75% r.h.
Auxiliary energy	DC +24 V
Installation position	Calibrated with vertical installation with the process connection pointing downwards
Application conditions	
Permitted Temperature ranges	Measuring material: -20 ... +85 °C (-4 ... +185 °F)
	Environment: -20 ... +60 °C (-4 ... +176 °F)
	Storage: -20 ... +70 °C (-4 ... +158 °F)
	Nominal temperature: 0 ... 80 °C (32 ... 176 °F)
Vibration resistance	20 g, 10 ... 2,000 Hz (IEC 60068-2-6, with resonance)
Shock resistance	50 g, 6 ms (IEC 60068-2-27, mechanical)
Mechanical service life	100 million load changes (10 million load changes for measuring ranges > 600 bar (8,702 psi))
Enclosure rating	IP65 and IP67 The enclosure ratings specified (as per IEC 60529) apply only with mating plugs of the corresponding enclosure rating when plugged in.
Installation position	Flexible
Contamination rating	max. 3
Air humidity	≤ 45 ... 75% r.h.
UV radiation	At high ambient temperatures and high UV radiation, the pressure switch must be installed with additional shading to prevent damage to the digital display and pushbuttons.

Technical data			
Electrical connection			
Plug connector	M12 round connector x 1 (4-pin or 5-pin)		
Short-circuit resistance	S+ / SP1 / SP2 to U-		
Reverse polarity protection	U+ to U-		
Insulation voltage	DC 500 V		
Over voltage protection	DC 40 V		
Pin assignment	See type label		
Materials			
Parts in contact with measuring material	< 1.0 bar (14.5 psi): 316L ≥ 1.0 bar (14.5 psi): 316L, PH steel		
Parts not in contact with measuring material	Housing	304	
	Keyboard	TPE-E	
	Display pane	PC	
	Display head	PC+ABS blend	
	Pressure transmission medium	Synthetic oil for all gauge pressure measuring ranges < 1.0 bar (14.5 psi), all absolute pressure measuring ranges and flush-mounted versions (< 1.6 bar (23.2 psi) with increased overload protection).	
Process connections			
Standard	Threaded size	Overload limit	Seal
SAE J1926, ISO T26	SAE 4	1.000 bar (14.500 psi) NBR	
ANSI/ASME B1.20.1	¼ NPT 1)	1.000 bar (14.500 psi)	-

Other process connections available with adapters.

Dimensions in mm (inch)

Pressure switch with round connector M12 x 1 (5-pin)

* Optionally suited for oxygen, free of oil and grease.

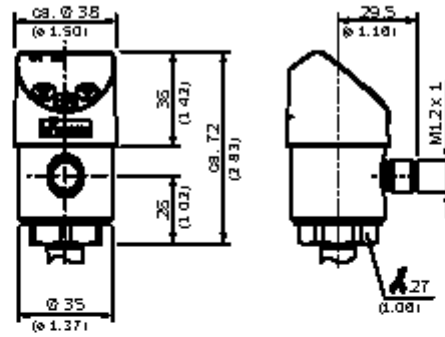

ONE J1928, ONE PDS



ONE 4 G-Ring Seal

G	L1
SAE 4J1928	9.1 (.36)

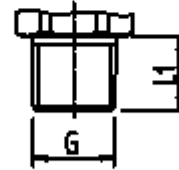

G	L1
1/4 NPT	13 (0.51)



The Productivity Devices Company

VEKTEK LLC
1334 E. 6th Ave
Emporia, Ks 66801
USA
Phone: 913-365-1045 (sales)
Fax: 816-364-0471 (sales)
620-342-7637 (technical service)
Email: sales@vektek.com
Website: www.vektek.com